



# Appliance Catalogs

Select from Samsung or Whirlpool appliances in the following catalogs

**SAMSUNG**

# Samsung Home Appliances





**SAMSUNG**

# The **new** **normal** is now.

Houses that manage the home.  
Refrigerators that do the grocery  
shopping. Washers that do two loads at  
once. And one app to control them all.

At Samsung, we're not predicting the  
future. We're creating it with practical  
innovation that turns heads and profits.  
It's all part of what's made Samsung  
**America's #1 home appliance brand**  
and the fastest growing appliance  
brand among builders.



# Overview

## ○ Chef Collection

- Wall Ovens
- Pro Ranges
- Cooktops
- Ventilation
- Dishwashers
- Refrigerators

## ○ Built-In Cooking

- Wall Ovens
- Cooktops

## ○ Ranges

- Slide-In
- Freestanding

## ○ Microwaves

- Over-the-Range
- Countertop

## ○ Ventilation

## ○ Dishwashers

## ○ Refrigerators

## ○ Laundry

- Front Load
- Top Load

## ○ Vacuums







# SAMSUNG

---

## CHEF COLLECTION

Download Spec Sheets and Line Drawings at [samsung.com/builder](https://samsung.com/builder)





## Chef Collection Wall Ovens

Single and Double Wall Ovens with Flex Duo™ feature a Smart Divider and separate controls that split the oven into two. The Microwave Combination Wall Oven features a Speed Cook microwave oven on top and a convection oven with Steam Cook on the bottom.

## Chef Collection Pro Ranges

A 22K BTU Dual Power Burner provides two independent burners, offering intense heat and precise control to quickly boil water or slowly melt chocolate without scorching.



## Chef Collection Induction and Gas Cooktops

Induction models feature a Flex Zone, which automatically adapts to the shape and size of your pots. Gas models with a 22K BTU Dual Power Burner feature two independent burners offering intense heat and precise control.

## Chef Collection Ventilation

Automatically adjusts the fan speed based on heat from the cooktop.



## Chef Collection Dishwashers

The WaterWall™ cleaning system delivers a powerful streaming wall of water to leave dishes remarkably clean. AutoRelease™ Door automatically opens the door at the end of a cycle to circulate air and accelerate drying time.

## Chef Collection Refrigerators

The 4-Door 42" Flex Built-In is designed with FlexZone™ that can easily switch from freezer to refrigerator.





# Samsung Chef Collection

## Inspired by chefs. Created for you.

Samsung Chef Collection perfectly blends advanced, chef-inspired technology with contemporary elegance.

### **Elegant Design**

Matte black stainless steel finishes with tactile details; seamless, flush-mount designs; and impeccable attention to detail.

### **Connected Technology**

Bluetooth® connectivity that brings your appliances to life; remote-view cameras and Wi-Fi enabled monitoring from your mobile device.

### **Chef-Inspired Performance**

Single ovens that convert into two; refrigerator compartments that easily switch from fridge to freezer; and dishwashers that clean with a wall of water.

## NV51M9770D

30" Double Wall Oven



### Available Colors



Fingerprint  
Resistant  
Matte Black  
Stainless Steel  
NV51M9770DM/AA



Stainless Steel  
NV51M9770DS/AA

### Integrated Flush Mount

Installation seamlessly blends in with cabinetry.

### One-Touch Steam Cook

Easy-fill steam tray delivers moisture at precise times for a crisp, browned outside and tender inside.

### Flex Duo™

Smart divider creates two different cooking zones by splitting the 5.1 cu. ft. super-capacity upper oven into two.



## NV51M9770S

30" Single Wall Oven



### Available Colors



Fingerprint  
Resistant  
Matte Black  
Stainless Steel  
NV51M9770SM/AA



Stainless Steel  
NV51M9770SS/AA

### Integrated Flush Mount

Installation seamlessly blends in with cabinetry.

### One-Touch Steam Cook

Easy-fill steam tray delivers moisture at precise times for a crisp, browned outside and tender inside.

### Flex Duo™

Smart divider creates two different cooking zones by splitting the 5.1 cu. ft. super-capacity oven into two.





# NQ70M9770

30" Microwave Combination Wall Oven

### Available Colors



Fingerprint Resistant Matte Black Stainless Steel  
NQ70M9770DM/AA



Stainless Steel  
NQ70M9770DS/AA

### Integrated Flush Mount

Installation seamlessly blends in with cabinetry.

### One-Touch Steam Cook

Easy-fill steam tray delivers moisture at precise times for a crisp, browned outside and tender inside.

### Speed Cook Oven

Allows you to bake, broil or microwave food in the 1.9 cu. ft. upper oven for faster and more even cooking.



# NX58M9960

30" Gas Pro Range

### Available Colors



Fingerprint Resistant Matte Black Stainless Steel  
NX58M9960PM/AA



Stainless Steel  
NX58M9960PS/AA

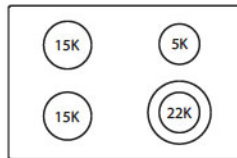

### 22K BTU Dual Power Burner

Two independent heating burners offer intense heat and precise control to quickly boil water or slowly melt chocolate without scorching.

### Dual Convection

Twin fans circulate air for fast, even cooking on all three racks.

### Bluetooth® Connectivity

Automatically starts the hood\* when the range turns on.

\* With compatible Samsung ventilation hood



# NZ30M9880

30" Induction Cooktop

Available Color



Black  
NZ30M9880UB/AA

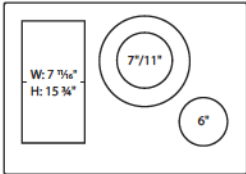

### Digital-Analog Controls

Choose between a removable magnetic analog knob or digital touch controls.

### Virtual Flame™ Technology

Virtual Flame™ technology gives the visual of gas cooking and the precision of induction cooking.

### Flex Zone

Flex Zone automatically adapts to the shape and size of your pots and pans.

# NZ36M9880

36" Induction Cooktop

Available Color



Black  
NZ36M9880UB/AA

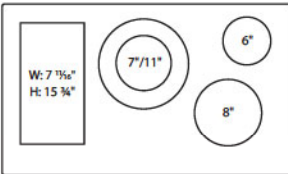

### Digital-Analog Controls

Choose between a removable magnetic analog knob or digital touch controls.

### Virtual Flame™ Technology

Virtual Flame™ technology gives the visual of gas cooking and the precision of induction cooking.

### Flex Zone

Flex Zone automatically adapts to the shape and size of your pots and pans.



# NA30N9755

30" Gas Cooktop



### Available Colors



Fingerprint Resistant Matte Black  
Stainless Steel  
NA30N9755TM/AA



Stainless Steel  
NA30N9755TS/AA

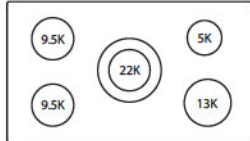

### Modern Design

Sleek, smooth, beveled front-control design with edge-to-edge, matte-finish, cast iron grates.

### 22K BTU Dual Power Burner

Two independent burners offer intense heat and precise control to quickly boil water or slowly melt chocolate without scorching.

### Bluetooth® Connectivity

Automatically starts the hood\* when the cooktop turns on.

\* With compatible Samsung ventilation hood

# NA36N9755

36" Gas Cooktop



### Available Colors



Fingerprint Resistant Matte Black  
Stainless Steel  
NA36N9755TM/AA



Stainless Steel  
NA36N9755TS/AA

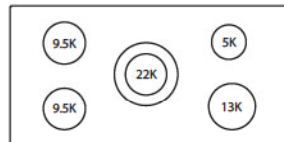

### Modern Design

Sleek, smooth, beveled front-control design with edge-to-edge, matte-finish, cast iron grates.

### 22K BTU Dual Power Burner

Two independent burners offer intense heat and precise control to quickly boil water or slowly melt chocolate without scorching.

### Bluetooth® Connectivity

Automatically starts the hood\* when the cooktop turns on.

\* With compatible Samsung ventilation hood



# NK30M9600

30" Range Hood

### Available Colors



Fingerprint Resistant Matte Black Stainless Steel

NK30M9600WM/AA



Stainless Steel NK30M9600WS/AA

### Auto Heat-Sensing Hood

Automatically adjusts the fan speed based on heat coming from the cooktop.

### Bluetooth® Connectivity

Connects the range\* or cooktop\* to the hood and automatically starts when they turn on.

### Dishwasher-Safe Baffle Filters

Help keep the air clean by drawing grease and odor through the hood.

\* When connected with a compatible Samsung range/cooktop



# NK36M9600

36" Range Hood

### Available Colors



Fingerprint Resistant Matte Black Stainless Steel

NK36M9600WM/AA



Stainless Steel NK36M9600WS/AA

### Auto Heat-Sensing Hood

Automatically adjusts the fan speed based on heat coming from the cooktop.

### Bluetooth® Connectivity

Connects the range\* or cooktop\* to the hood and automatically starts when they turn on.

### Dishwasher-Safe Baffle Filters

Help keep the air clean by drawing grease and odor through the hood.

\* When connected with a compatible Samsung range/cooktop



# DW60M9990

Panel-Ready WaterWall™ Dishwasher

#### Available Color



Panel-Ready  
DW60M9990AP/AA

#### Panel-Ready Design\*

Seamlessly blends in with existing cabinetry.

#### AutoRelease™ Door

Automatically opens the door at the end of a cycle to circulate air and accelerate drying time.

#### WaterWall™

Delivers corner-to-corner coverage, so that even your dirtiest dishes will come clean.

\* Custom panel and handle not included



# DW80M9990

WaterWall™ Dishwasher

#### Available Colors



Matte Black  
Stainless Steel  
DW80M9990UM/AA



Stainless Steel  
DW80M9990US/AA

#### Modern Design

Premium, horizontal brushed metal finish brings beauty to any kitchen.

#### AutoRelease™ Door

Automatically opens the door at the end of a cycle to circulate air and accelerate drying time.

#### WaterWall™

Delivers corner-to-corner coverage, so that even your dirtiest dishes will come clean.





# BRF425200

42" 4-Door Flex™ Built-In Refrigerator  
23.5 cu. ft. capacity



#### Available Color



Panel-Ready  
BRF425200AP/AA

#### Accessory Kit Options\*



Fingerprint  
Resistant  
Matte Black  
Stainless Steel



Fingerprint  
Resistant  
Stainless  
Steel

RAT42ACAAMS/AA RAT42ACAAS4/AA

#### Integrated Flush Mount

Counter-depth, panel-ready design seamlessly blends in with cabinetry and aligns perfectly with countertops.

#### Wi-Fi Enabled with Remote View Cameras

Allows you to view what's inside your refrigerator directly from your mobile device.

#### FlexZone™

Convertible zone that has four different temperature settings, allowing you to easily switch from freezer to refrigerator.

\*Matte Black Stainless Steel and Stainless Steel require additional purchase of accessory kit - RAT42ACAAMS or RAT42ACAAS4



# BRF365200

36" French Door Built-In Refrigerator  
21.3 cu. ft. capacity



#### Available Color



Panel-Ready  
BRF365200AP/AA



Fingerprint  
Resistant  
Matte Black  
Stainless Steel



Fingerprint  
Resistant  
Stainless  
Steel

RAF36ACAAMS/AA RAF36ACAAS4/AA

#### Integrated Flush Mount

Counter-depth, panel-ready design seamlessly blends in with cabinetry and aligns perfectly with countertops.

#### Wi-Fi Enabled with Remote View Cameras

Allows you to view what's inside your refrigerator directly from your mobile device.

#### Twin Cooling Plus™

Maintains high levels of refrigerator humidity to keep fruits and vegetables fresher longer, as well as dry freezer conditions to minimize freezer burn.

\*Matte Black Stainless Steel and Stainless Steel require additional purchase of accessory kit - RAF36ACAAMS or RAF36ACAAS4





# RF23M8960

36" 4-Door French Door Counter-Depth Refrigerator  
22.6 cu. ft. capacity

#### Available Colors



Fingerprint  
Resistant  
Matte Black  
Stainless Steel  
RF23M8960MT/AA



Fingerprint  
Resistant  
Stainless Steel  
RF23M8960S4/AA



#### Sleek Counter-Depth Look

Counter-depth design offers a sleek, built-in look.

#### Autofill Pitcher with Infuser

The built-in Autofill Pitcher automatically refills, providing cold water anytime you need it and the option to infuse your favorite refreshing flavor.

#### FlexZone™ Drawer

Separately controlled FlexZone™ drawer allows you to set four different temperatures.



# Chef Collection

## Wall Ovens • Pro Ranges



## Wall Ovens



| Model                              | NQ70M9770   | NV51M9770D  | NV51M9770S   |
|------------------------------------|---|---|--|
| <b>Platform</b>                    | Microwave Combination Wall Oven   | Double Wall Oven  | Single Wall Oven   |
| <b>Capacity</b>                    | 1.9 cu. ft. Microwave + 5.1 cu. ft. Total Oven, 2.8/2.2 cu. ft.   | 5.1 cu. ft. Upper Total, 2.8/2.2 cu. ft./ 5.1 cu. ft. Lower   | 5.1 cu. ft. Total, 2.8/2.2 cu. ft.   |
| <b>Wi-Fi Connectivity</b>          | ✓   | ✓   | ✓  |
| <b>Steam Cook</b>                  | ✓ (Lower)   | ✓ (Upper)   | ✓  |
| <b>Flex Duo™</b>                   | ✓ (Lower)   | ✓ (Upper)   | ✓  |
| <b>Controls</b>                    | Digital-Analog  | Digital-Analog  | Digital-Analog   |
| <b>Convection</b>                  | Speed Cook (Microwave), Speed Power Conv. (Microwave), Dual Convection (Oven)   | Dual Convection   | Dual Convection  |
| <b>No Preheat</b>                  | ✓   | ✓   | ✓  |
| <b>Slim Fry™</b>                   | ✓   |   |  |
| <b>Gourmet Cook</b>                | ✓   | ✓   | ✓  |
| <b>Chef Cooking Modes</b>          | ✓   | ✓   | ✓  |
| <b>Cleaning</b>                    | Hybrid Clean & Self-Clean (Oven)  | Hybrid Clean & Self-Clean   | Hybrid Clean & Self-Clean  |
| <b>Door Design</b>                 | Soft Close Door   | Soft Close Door   | Soft Close Door  |
| <b>Racks</b>                       | Ceramic Plate (Microwave) + 2 Gliding + 1 Standard  | 3 Gliding + 3 Standard  | 2 Gliding + 1 Standard   |
| <b>Additional Features</b>         | Temperature Probe, LED Spotlights, LCD Display, Easy View Window  | Temperature Probe, LED Spotlights, LCD Display, Easy View Window  | Temperature Probe, LED Spotlights, LCD Display, Easy View Window   |
| <b>Sabbath Mode</b>                | ★   | ★   | ★  |
| <b>Installation</b>                | Flush or Standard   | Flush or Standard   | Flush or Standard  |
| <b>Door Handles</b>                | Chef Handle   | Chef Handle   | Chef Handle  |
| <b>Power Ratings</b>               | 240V / 9.5 kW / 40 Amps, 208V / 7.2 kW / 40 Amps  | 240V / 10.6 kW / 50 Amps, 208V / 8.0 kW / 40 Amps   | 240V / 6.2 kW / 30 Amps, 208V / 4.7 kW / 30 Amps   |
| <b>Color Options</b>               | Stainless, Matte Black Stainless*   | Stainless, Matte Black Stainless*   | Stainless, Matte Black Stainless*  |
| <b>Oven Interior Color Options</b> | Blue  | Blue  | Blue   |
| <b>Cut-Out Dimensions (WxHxD)</b>  | Standard Install: 28 <sup>1</sup> / <sub>2</sub> " x 42 <sup>1</sup> / <sub>4</sub> " x 23 <sup>1</sup> / <sub>2</sub> "<br>Flush Install: 30 <sup>1</sup> / <sub>4</sub> " x 43 <sup>11</sup> / <sub>16</sub> " x 24 <sup>7</sup> / <sub>8</sub> " | Standard Install: 28 <sup>1</sup> / <sub>2</sub> " x 50 <sup>1</sup> / <sub>4</sub> " x 23 <sup>1</sup> / <sub>2</sub> "<br>Flush Install: 30 <sup>1</sup> / <sub>4</sub> " x 51 <sup>7</sup> / <sub>8</sub> " x 24 <sup>7</sup> / <sub>8</sub> " | Standard Install: 28 <sup>1</sup> / <sub>2</sub> " x 27 <sup>1</sup> / <sub>4</sub> " x 23 <sup>1</sup> / <sub>2</sub> "<br>Flush Install: 30 <sup>1</sup> / <sub>4</sub> " x 29" x 24 <sup>7</sup> / <sub>8</sub> " |
| <b>Outside Dimensions (WxHxD)</b>  | 29 <sup>3</sup> / <sub>4</sub> " x 43 <sup>3</sup> / <sub>8</sub> " x 26 <sup>3</sup> / <sub>8</sub> "  | 29 <sup>3</sup> / <sub>4</sub> " x 51 <sup>1</sup> / <sub>2</sub> " x 26 <sup>5</sup> / <sub>8</sub> "  | 29 <sup>3</sup> / <sub>4</sub> " x 28 <sup>7</sup> / <sub>8</sub> " x 26 <sup>5</sup> / <sub>8</sub> "   |

\*Fingerprint-resistant finish

## Pro Ranges



| Model                               | NX58M9960   |
|-------------------------------------|---|
| <b>Platform</b>                     | 30" Gas Pro Range   |
| <b>Oven Capacity</b>                | 5.8 cu. ft.   |
| <b>Wi-Fi Monitoring</b>             | ✓   |
| <b>Bluetooth® Hood Connectivity</b> | ✓   |
| <b>Cooktop Configuration</b>        | 4 Burners:<br>1- 22K BTU Dual Brass Burner<br>2- 15K Power Burner<br>1- 5K Simmer |
| <b>Total Power</b>                  | 57K BTU   |
| <b>Controls</b>                     | Blue LED Illuminated Knobs  |
| <b>Convection</b>                   | Dual Convection   |
| <b>Cleaning</b>                     | Self-Clean  |
| <b>Soft Close Door</b>              | ✓   |
| <b>Racks</b>                        | 1 Gliding + 2 Standard  |
| <b>Additional Features</b>          | Wok Grate   |
| <b>ADA Compliant</b>                | ✓   |
| <b>Door Handles</b>                 | Chef Handle   |
| <b>Power Ratings</b>                | 120V / 60 Hz / 10 Amps  |
| <b>Color Options</b>                | Stainless, Matte Black Stainless*   |
| <b>Oven Interior Color Options</b>  | Blue  |
| <b>Outside Dimensions (WxHxD)</b>   | 29 <sup>15</sup> / <sub>16</sub> " x 38" x 28 <sup>7</sup> / <sub>16</sub> "      |

\*Fingerprint-resistant finish



# Chef Collection

## Cooktops · Ventilation



## Cooktops



| Model                               | NZ36M9880   | NZ30M9880   | NA36N9755   | NA30N9755   |
|-------------------------------------|---|---|---|---|
| <b>Platform</b>                     | 36" Induction   | 30" Induction   | 36" Gas   | 30" Gas   |
| <b>Flex Zone</b>                    | ✓   | ✓   |   |   |
| <b>Virtual Flame™</b>               | ✓   | ✓   |   |   |
| <b>Wi-Fi Monitoring</b>             | ✓   | ✓   | ✓   | ✓   |
| <b>Bluetooth® Hood Connectivity</b> | ✓   | ✓   | ✓   | ✓   |
| <b>Sync Elements</b>                | ✓   | ✓   |   |   |
| <b>Controls</b>                     | Digital Touch + Magnetic Knob   | Digital Touch + Magnetic Knob   | Blue LED Illuminated Knobs  | Blue LED Illuminated Knobs  |
| <b>Cooktop Configuration</b>        | 5 Elements:<br>2 - Flex Zone – 1.8/2.6 kW Boost,<br>8" – 2.2/3.2 kW Boost,<br>6" – 1.4/1.8 kW Boost,<br>7"/11" – 3.6/4.8 kW Boost | 4 Elements:<br>2 - Flex Zone – 1.8/2.6 kW Boost,<br>6" – 1.4/1.8 kW Boost,<br>7"/11" – 3.6/4.8 kW Boost | 5 Burners:<br>22K BTU Dual (Brass),<br>2 - 9.5K BTU,<br>13K BTU Power Burner,<br>5K BTU Simmer        | 5 Burners:<br>22K BTU Dual (Brass),<br>2 - 9.5K BTU,<br>13K BTU Power Burner,<br>5K BTU Simmer        |
| <b>Total Power</b>                  | 10.8 kW   | 8.6 kW  | 59K BTUs  | 59K BTUs  |
| <b>Power Boost</b>                  | ✓   | ✓   |   |   |
| <b>Power Levels</b>                 | 15  | 15  |   |   |
| <b>Power Ratings</b>                | 240V / 60 Hz / 45 Amps  | 240V / 60 Hz / 40 Amps  | 120V / 60 Hz / 1 Amp  | 120V / 60 Hz / 1 Amp  |
| <b>ADA Compliant</b>                | ✓   | ✓   | ✓   | ✓   |
| <b>Additional Features</b>          |   |   | Cast Iron Griddle, Wok Grate  | Cast Iron Griddle, Wok Grate  |
| <b>Color Options</b>                | Black   | Black   | Stainless,<br>Matte Black Stainless <sup>1</sup>  | Stainless,<br>Matte Black Stainless <sup>1</sup>  |
| <b>Cut-Out Dimensions (WxHxD)</b>   | 33 <sup>7</sup> / <sub>8</sub> " x 4" x 19 <sup>1</sup> / <sub>8</sub> "  | 28 <sup>1</sup> / <sub>2</sub> " x 4" x 19 <sup>9</sup> / <sub>16</sub> "                               | 33 <sup>7</sup> / <sub>8</sub> " x 3 <sup>1</sup> / <sub>8</sub> " x 19 <sup>1</sup> / <sub>8</sub> " | 28 <sup>1</sup> / <sub>2</sub> " x 3 <sup>1</sup> / <sub>8</sub> " x 19 <sup>5</sup> / <sub>8</sub> " |
| <b>Outside Dimensions (WxHxD)</b>   | 36" x 4" x 21 <sup>1</sup> / <sub>4</sub> "   | 30" x 4" x 21 <sup>1</sup> / <sub>4</sub> "   | 36" x 5 <sup>41</sup> / <sub>72</sub> " x 22 <sup>1</sup> / <sub>3</sub> "                            | 30" x 5 <sup>41</sup> / <sub>72</sub> " x 22 <sup>1</sup> / <sub>3</sub> "                            |

<sup>1</sup>Fingerprint-resistant finish

## Ventilation



| Model                                | NK36M9600  | NK30M9600  |
|--------------------------------------|--|--|
| <b>Platform</b>                      | 36" Wall Mount   | 30" Wall Mount   |
| <b>Wi-Fi Monitoring<sup>2</sup></b>  | ✓  | ✓  |
| <b>Bluetooth® Connectivity</b>       | ✓  | ✓  |
| <b># of Removable Baffle Filters</b> | 3  | 2  |
| <b>Controls</b>                      | Digital Touch Control  | Digital Touch Control  |
| <b>LED Lights</b>                    | ✓  | ✓  |
| <b>Fan Speeds</b>                    | 4 including Boost  | 4 including Boost  |
| <b>CFM</b>                           | 390 CFM (600 CFM capable)  | 390 CFM (600 CFM capable)  |
| <b>Venting</b>                       | Exterior Venting & Recirculating Capable   | Exterior Venting & Recirculating Capable   |
| <b>Noise Level</b>                   | 74 dBA (10.8 sonnes)   | 74 dBA (10.8 sonnes)   |
| <b>Auto Heat-Sensing</b>             | ✓  | ✓  |
| <b>Optional Hood Extension Kit</b>   | NK-AE905LWS (Stainless),<br>NK-AE905LWM<br>(Matte Black Stainless <sup>1</sup> ) | NK-AE905LWS (Stainless),<br>NK-AE905LWM<br>(Matte Black Stainless <sup>1</sup> ) |
| <b>Optional Recirculation Kit</b>    | NK-AF030FNB  | NK-AF030FNB  |
| <b>Replacement Charcoal Filter</b>   | NK-AR050FNB  | NK-AR050FNB  |
| <b>ADA Compliant</b>                 | ✓  | ✓  |
| <b>Power Ratings</b>                 | 120V / 60 Hz / 15 Amps   | 120V / 60 Hz / 15 Amps   |
| <b>Color Options</b>                 | Stainless,<br>Matte Black Stainless <sup>1</sup>                                 | Stainless,<br>Matte Black Stainless <sup>1</sup>                                 |
| <b>Dimensions (WxHxD)</b>            | 36" x 25 <sup>7</sup> / <sub>16</sub> " x 19 <sup>11</sup> / <sub>16</sub> "     | 30" x 25 <sup>7</sup> / <sub>16</sub> " x 19 <sup>11</sup> / <sub>16</sub> "     |

<sup>1</sup>Fingerprint-resistant finish

<sup>2</sup>Only when connected through Bluetooth®



# Chef Collection

## Dishwashers · Refrigerators





## Dishwashers



| Model                                  | DW80M9990  | DW60M9990  |
|--|--|--|
| <b>Platform</b>                        | 24" Built-in Dishwasher  | 24" Built-in Dishwasher  |
| <b>Cleaning System</b>                 | WaterWall™   | WaterWall™   |
| <b>Wi-Fi Enabled</b>                   | ✓  | ✓  |
| <b>Quiet Sound: dBA</b>                | 38 dBA   | 44 dBA   |
| <b>AutoRelease™ Door</b>               | ✓  | ✓  |
| <b>Third Rack</b>                      | ✓  | ✓  |
| <b>Zone Booster™</b>                   | ✓  | ✓  |
| <b>Cycles/Options</b>                  | 7/8  | 7/7  |
| <b>Chef Cycle</b>                      | ✓  |  |
| <b>Hidden Touch Controls</b>           | ✓  | ✓  |
| <b>Flextray™</b>                       | ✓  |  |
| <b>Smooth Glide Rails</b>              | ✓  | ✓  |
| <b>One Touch Adjustable Upper Rack</b> | ✓  | ✓  |
| <b>Drying System</b>                   | Condensation Drying w/ AutoRelease™ Door and Fan Assist                          | Condensation Drying w/ AutoRelease™ Door and Fan Assist  |
| <b>Smart Leak Detector</b>             | ✓  | ✓  |
| <b># Place Settings</b>                | 15   | 14   |
| <b>Silverware Basket</b>               | ✓  | ✓  |
| <b>ENERGY STAR®</b>                    | ENERGY STAR® "Most Efficient"  | ✓  |
| <b>Door Handle</b>                     | Pocket   |  |
| <b>Power Ratings</b>                   | 120V / 60 Hz / 15 Amps   | 120V / 60 Hz / 15 Amps   |
| <b>Color Options</b>                   | Stainless, Matte Black Stainless <sup>1</sup>                                    | Panel-Ready  |
| <b>Dimensions (WxHxD)</b>              | 23 <sup>7</sup> / <sub>8</sub> " x 33 <sup>7</sup> / <sub>8</sub> " to 35" x 25" | 23 <sup>1</sup> / <sub>2</sub> " x 32 <sup>1</sup> / <sub>4</sub> " to 34 <sup>5</sup> / <sub>8</sub> " x 21 <sup>7</sup> / <sub>8</sub> " |

## Refrigerators



| Model  | BRF425200   | BRF365200   | RF23M8960   |
|--|---|---|---|
| <b>Platform</b>                                      | 42" 4-Door Flex™ Built-In Refrigerator  | 36" French Door Built-In Refrigerator   | 36" Counter Depth French Door Freestanding Refrigerator                   |
| <b>Capacity</b>                                      | Total: 23.5 cu.ft.<br>Refrigerator: 16.8 cu. ft.<br>Freezer: 6.7 cu. ft.                    | Total: 21.3 cu.ft.<br>Refrigerator: 14.5 cu. ft.<br>Freezer: 6.8 cu. ft.                    | Total: 22.6 cu.ft.<br>Refrigerator: 16 cu. ft.<br>Freezer: 6.6 cu. ft.    |
| <b>Panel Accessory Kit Color Options<sup>2</sup></b> | RAT42ACAAS4 (Stainless <sup>2</sup> ),<br>RAT42ACAAMS (Matte Black Stainless <sup>2</sup> ) | RAF36ACAAS4 (Stainless <sup>2</sup> ),<br>RAF36ACAAMS (Matte Black Stainless <sup>2</sup> ) |   |
| <b>Flexible Storage</b>                              | FlexZone™ Compartment (4 temp options),<br>Chef Pantry Drawer (3 temp options)              | Chef Pantry Drawer (3 temp options)   | FlexZone™ Drawer (4 temp options)   |
| <b>Lighting</b>                                      | Frame LED   | Frame LED   | HE LED  |
| <b>Cooling System</b>                                | Triple & Metal Cooling (Precise Chef Cooling)   | Twin Cooling Plus™ & Metal Cooling (Precise Chef Cooling)                                   | Twin Cooling Plus™ & Metal Cooling  |
| <b>Wi-Fi Enabled</b>                                 | ✓   | ✓   | Dongle Ready <sup>3</sup>   |
| <b>Remote View Cameras</b>                           | ✓   | ✓   |   |
| <b>Remote Diagnostics</b>                            | ✓   | ✓   |   |
| <b>Water Dispenser</b>                               | Internal  | Internal  | External and Autofill Pitcher with Infuser                                |
| <b>Water Filter</b>                                  | HAF-QIN DA97-17376B   | HAF-QIN DA97-17376B   | HAF-QIN DA97-17376B   |
| <b>Deodorizing Filter</b>                            | ✓   | ✓   |   |
| <b>ENERGY STAR®</b>                                  | CEE Tier 1  | CEE Tier 3  | CEE Tier 2  |
| <b>Sabbath Mode</b>                                  | ★   | ★   | ★   |
| <b>Door Handle<sup>1</sup></b>                       | Chef Handle   | Chef Handle   | Chef Handle   |
| <b>Power Ratings</b>                                 | 115V / 60 Hz / 6 Amps   | 115V / 60 Hz / 6 Amps   | 115V / 60 Hz / 6 Amps   |
| <b>Color Options</b>                                 | Stainless <sup>2</sup> , Matte Black Stainless <sup>2</sup> ,<br>Panel-Ready                | Stainless <sup>2</sup> , Matte Black Stainless <sup>2</sup> ,<br>Panel-Ready                | Stainless <sup>2</sup> , Matte Black Stainless <sup>2</sup>               |
| <b>Dimensions (WxHxD)</b>                            | 41 <sup>1</sup> / <sub>4</sub> " x 83 <sup>3</sup> / <sub>8</sub> " x 25"                   | 35 <sup>3</sup> / <sub>4</sub> " x 83 <sup>3</sup> / <sub>8</sub> " x 25"                   | 35 <sup>3</sup> / <sub>4</sub> " x 70" x 30 <sup>1</sup> / <sub>2</sub> " |

<sup>1</sup>For BRF models, panel accessory kits are required  
<sup>2</sup>Fingerprint-resistant finish  
<sup>3</sup>Dongle part number is the HD2018GH Smart Adapter





# Built-In Cooking

Download Spec Sheets and Line Drawings at [samsung.com/builder](http://samsung.com/builder)





## The Power of Steam

Steam cooking technology delivers moisture at precise times, so food has a crisp exterior and tender inside.

## Flexible Cooking

The removable Flex Duo™ Smart Divider splits one oven into two. Cook two dishes at two different temperatures, or choose to have one large-capacity oven.



## Intuitive Display

Enjoy the convenience of analog knobs combined with the advanced technology of a touch-controlled digital display.

## Induction Cooking

Virtual Flame™ technology provides a superior cooking experience by combining the visual of gas cooking with the precision of induction cooking.



## Precision Control

Choose between the comfort of the removable magnetic analog knob or the sleek interface of digital touch controls.

## NQ70M7770D

30" Microwave Combination Wall Oven

### Available Colors



Fingerprint  
Resistant Black  
Stainless Steel  
NQ70M7770DG/AA



Stainless Steel  
NQ70M7770DS/AA

### 1.9/5.1 cu. ft. Capacity

The largest-capacity microwave combination wall oven among leading brands.\*

### Flex Duo™

Cooks two dishes at different temperatures simultaneously with the Smart Divider.

### Steam Cook (Oven)

Delivers moisture at precise times for a crisp, browned outside and tender inside.

### Speed Cook (Microwave)

Cook food faster and more evenly by using true convection.

### Digital-Analog Controls

A combination of analog knobs and a digital touchscreen.

\*Based on 2016 unit sales among brands with over 90% market share of major kitchen appliances (TraQline)



## NQ70M6650D

30" Microwave Combination Wall Oven

### Available Colors



Fingerprint  
Resistant Black  
Stainless Steel  
NQ70M6650DG/AA



Stainless Steel  
NQ70M6650DS/AA

### 1.9/5.1 cu. ft. Capacity

The largest-capacity microwave combination wall oven among leading brands.\*

### Steam Cook (Oven)

Delivers moisture at precise times for a crisp, browned outside and tender inside.

### Dual Convection (Oven)

Circulates air for faster, more even cooking using true convection.

### Speed Cook (Microwave)

Cook food faster and more evenly by using power convection.

### Guiding Light Controls

Intuitive, with simple, step-by-step instructions for choosing cooking options.

\*Based on 2016 unit sales among brands with over 90% market share of major kitchen appliances (TraQline)



# NV51K7770D

30" Double Wall Oven



### Available Colors



Fingerprint  
Resistant Black  
Stainless Steel  
NV51K7770DG/AA



Stainless Steel  
NV51K7770DS/AA

### 5.1/5.1 cu. ft. Capacity

Accommodates a roast, multiple casserole dishes or several racks of cookies.

### Flex Duo™

Cook three dishes at different temperatures simultaneously with the Smart Divider.

### Steam Cook

Delivers moisture at precise times for a crisp, browned outside and tender inside.

### Dual Convection

Circulates air for more even and efficient cooking results.

### Digital-Analog Controls

A combination of analog knobs and a digital touchscreen.

# NV51K7770S

30" Single Wall Oven



### Available Colors



Fingerprint  
Resistant Black  
Stainless Steel  
NV51K7770SG/AA



Stainless Steel  
NV51K7770SS/AA

### 5.1 cu. ft. Capacity

Accommodates a roast, multiple casserole dishes or several racks of cookies.

### Flex Duo™

Cook two dishes at different temperatures simultaneously with the Smart Divider.

### Steam Cook

Delivers moisture at precise times for a crisp, browned outside and tender inside.

### Dual Convection

Circulates air for more even and efficient cooking results.

### Digital-Analog Controls

A combination of analog knobs and a digital touchscreen.



# NV51K6650D

30" Double Wall Oven

### Available Colors



Fingerprint  
Resistant Black  
Stainless Steel  
NV51K6650DG/AA



Stainless Steel  
NV51K6650DS/AA

### 5.1/5.1 cu. ft. Capacity

Accommodates a roast, multiple casserole dishes or several racks of cookies.

### Steam Cook

Delivers moisture at precise times for a crisp, browned outside and tender inside.

### Dual Convection

Two fans circulate air for faster, more even and efficient cooking.

### Guiding Light Controls

Intuitive, with simple step-by-step instructions for choosing cooking options.

### Wi-Fi Connectivity

Remotely monitor and control the oven from your smartphone.



# NV51K6650S

30" Single Wall Oven

### Available Colors



Fingerprint  
Resistant Black  
Stainless Steel  
NV51K6650SG/AA



Stainless Steel  
NV51K6650SS/AA

### 5.1 cu. ft. Capacity

Accommodates a roast, multiple casserole dishes or several racks of cookies.

### Steam Cook

Delivers moisture at precise times for a crisp, browned outside and tender inside.

### Dual Convection

Two fans circulate air for faster, more even and efficient cooking.

### Guiding Light Controls

Intuitive, with simple step-by-step instructions for choosing cooking options.

### Wi-Fi Connectivity

Remotely monitor and control the oven from your smartphone.





## NZ30K7880

30" Induction Cooktop



### Available Colors



Fingerprint  
Resistant Black  
Stainless Steel  
NZ30K7880UG/AA



Stainless Steel  
NZ30K7880US/AA

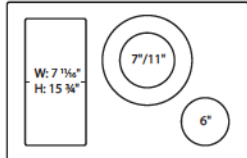

### Virtual Flame™ Technology

LED surface lights shine onto pans to give the visual of gas cooking with the precision of induction.

### Flex Zone

Large cooking area designed to adapt to different pot shapes and sizes for optimal flexibility.

### Power Boost

Focused heat increases intensity on any element for faster boiling times.

### Digital-Analog Controls

The ultimate interface; choose between a removable magnetic analog knob or digital touch controls.

### Wi-Fi Connectivity

Remotely monitor the cooktop from your smartphone.

## NZ36K7880

36" Induction Cooktop



### Available Colors



Fingerprint  
Resistant Black  
Stainless Steel  
NZ36K7880UG/AA



Stainless Steel  
NZ36K7880US/AA

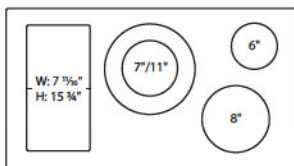

### Virtual Flame™ Technology

LED surface lights shine onto pans to give the visual of gas cooking with the precision of induction.

### Flex Zone

Large cooking area designed to adapt to different pot shapes and sizes for optimal flexibility.

### Power Boost

Focused heat increases intensity on any element for faster boiling times.

### Digital-Analog Controls

The ultimate interface; choose between a removable magnetic analog knob or digital touch controls.

### Wi-Fi Connectivity

Remotely monitor the cooktop from your smartphone.



## NZ30K7570

### 30" Electric Cooktop

#### Available Colors



Fingerprint Resistant Black Stainless Steel  
NZ30K7570RG/AA



Stainless Steel  
NZ30K7570RS/AA

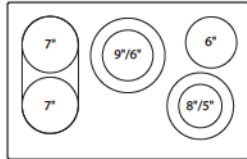

#### Rapid Boil™

Up to 3.3 kW power element offers intense heat and precise control to quickly boil water or maintain a low, even simmer.

#### Digital-Analog Controls

The ultimate interface; choose between a removable magnetic analog knob or digital touch controls.

#### Sync Control Elements

Control two elements at the same time when using a large pot or griddle across two elements.

#### Bluetooth® Connected to Hood

Cooktop can sync to the hood so that you can automatically start the fans and lights when the elements turn on.

#### Wi-Fi Connectivity

Remotely monitor the cooktop from your smartphone.

## NZ36K7570

### 36" Electric Cooktop

#### Available Colors



Fingerprint Resistant Black Stainless Steel  
NZ36K7570RG/AA



Stainless Steel  
NZ36K7570RS/AA

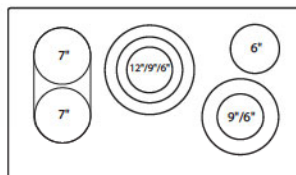

#### Rapid Boil™

Up to 3.3 kW power element offers intense heat and precise control to quickly boil water or maintain a low, even simmer.

#### Digital-Analog Controls

The ultimate interface; choose between a removable magnetic analog knob or digital touch controls.

#### Sync Control Elements

Control two elements at the same time when using a large pot or griddle across two elements.

#### Bluetooth® Connected to Hood

Cooktop can sync to the hood so that you can automatically start the fans and lights when the elements turn on.

#### Wi-Fi Connectivity

Remotely monitor the cooktop from your smartphone.



# NZ30K6330

## 30" Electric Cooktop



### Available Colors



Fingerprint Resistant Black Stainless Steel  
NZ30K6330RG/AA



Stainless Steel  
NZ30K6330RS/AA

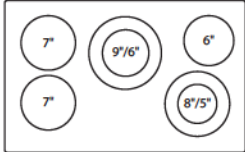

### Rapid Boil™

Up to 3.3 kW power element offers intense heat and precise control to quickly boil water or maintain a low, even simmer.

### Flexible Cooktop

Whether you're boiling water, melting chocolate or simmering sauce, there's an element for your needs.

### Blue LED Illuminated Knobs

Visually lets you know your cooktop is on, even from a distance.

### Hot Surface Indicator Lights

Indicator light lets you know the surface is hot.

### Wi-Fi Connectivity

Remotely monitor the cooktop from your smartphone.

# NZ36K6430

## 36" Electric Cooktop



### Available Colors



Fingerprint Resistant Black Stainless Steel  
NZ36K6430RG/AA



Stainless Steel  
NZ36K6430RS/AA

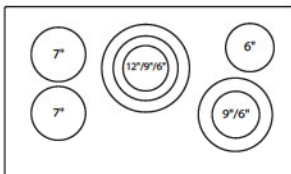

### Rapid Boil™

Up to 3.3 kW power element offers intense heat and precise control to quickly boil water or maintain a low, even simmer.

### Flexible Cooktop

Whether you're boiling water, melting chocolate or simmering sauce, there's an element for your needs.

### Blue LED Illuminated Knobs

Visually lets you know your cooktop is on, even from a distance.

### Hot Surface Indicator Lights

Indicator light lets you know the surface is hot.

### Wi-Fi Connectivity

Remotely monitor the cooktop from your smartphone.



# NA30N7755

30" Gas Cooktop

### Available Colors



Fingerprint  
Resistant Black  
Stainless Steel  
NA30N7755TG/AA



Stainless Steel  
NA30N7755TS/AA

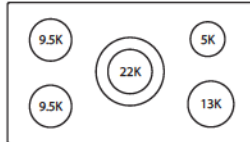

### 22K BTU True Dual-Power Burner

Two independent heating burners offer intense heat and precise control to quickly boil water or reduce to a low simmer.

### Cast Iron Griddle

Cook breakfast, grill sandwiches or sauté vegetables on the removable griddle.

### Analog Controls with Digital Wi-Fi and Bluetooth® Technology

The ultimate combination of analog comfort and digital technology delivers exceptional cooking performance.

### Blue LED Illuminated Knobs

Visually lets you know if the cooktop is on, even from a distance.

### Wi-Fi Connectivity

Remotely monitor the cooktop from your smartphone.

# NA36N7755

36" Gas Cooktop

### Available Colors



Fingerprint  
Resistant Black  
Stainless Steel  
NA36N7755TG/AA



Stainless Steel  
NA36N7755TS/AA

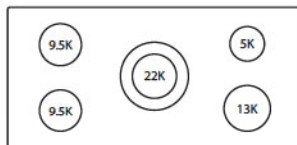

### 22K BTU True Dual-Power Burner

Two independent heating burners offer intense heat and precise control to quickly boil water or reduce to a low simmer.

### Cast Iron Griddle

Cook breakfast, grill sandwiches or sauté vegetables on the removable griddle.

### Analog Controls with Digital Wi-Fi and Bluetooth® Technology

The ultimate combination of analog comfort and digital technology delivers exceptional cooking performance.

### Blue LED Illuminated Knobs

Visually lets you know if the cooktop is on, even from a distance.

### Wi-Fi Connectivity

Remotely monitor the cooktop from your smartphone.





# NA30N6555

30" Gas Cooktop



### Available Colors



Fingerprint Resistant Black Stainless Steel  
NA30N6555TG/AA



Stainless Steel  
NA30N6555TS/AA

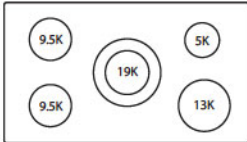

### 19K BTU Power Burner

Powerful burner boils water faster.

### Flexible Cooktop

Five powerful burners have the flexibility to accommodate a number of dishes at once.

### Griddle

Cook breakfast, grill sandwiches or sauté vegetables on the griddle.

### Blue LED Illuminated Knobs

Visually lets you know if the cooktop is on, even from a distance.

### Wi-Fi Connectivity

Remotely monitor the cooktop from your smartphone.

# NA36N6555

36" Gas Cooktop



### Available Colors



Fingerprint Resistant Black Stainless Steel  
NA36N6555TG/AA



Stainless Steel  
NA36N6555TS/AA



### 19K BTU Power Burner

Powerful burner boils water faster.

### Flexible Cooktop

Five powerful burners have the flexibility to accommodate a number of dishes at once.

### Griddle

Cook breakfast, grill sandwiches or sauté vegetables on the griddle.

### Blue LED Illuminated Knobs

Visually lets you know if the cooktop is on, even from a distance.

### Wi-Fi Connectivity

Remotely monitor the cooktop from your smartphone.





# Built-In Cooking Wall Ovens





| Model                              | NQ70M7770D   | NQ70M6650D   | NV51K7770D   | NV51K6650D   | NV51K7770S   | NV51K6650S   |
|------------------------------------|--|--|--|--|--|--|
| <b>Platform</b>                    | Microwave Combination Wall Oven  | Microwave Combination Wall Oven  | Double Wall Oven   | Double Wall Oven   | Single Wall Oven   | Single Wall Oven   |
| <b>Capacity</b>                    | Microwave Oven: 1.9 cu. ft.<br>Oven: 5.1 cu. ft. total<br>2.8/2.2 cu. ft.                                | Microwave Oven: 1.9 cu. ft.<br>Oven: 5.1 cu. ft.   | Top Oven: 5.1 cu. ft.<br>Bottom Oven: 5.1 cu. ft. total<br>2.8/2.2 cu. ft.                               | Top Oven: 5.1 cu. ft.<br>Bottom Oven: 5.1 cu. ft.  | 5.1 cu. ft. total<br>2.8/2.2 cu. ft.   | 5.1 cu. ft.  |
| <b>Wi-Fi Connectivity</b>          | ✓  | ✓  | ✓  | ✓  | ✓  | ✓  |
| <b>Steam Cook</b>                  | ✓  | ✓  | ✓  | ✓  | ✓  | ✓  |
| <b>Speed Cook (MWO)</b>            | ✓ (Power Convection)   | ✓ (Convection)   |  |  |  |  |
| <b>Flex Duo™</b>                   | ✓  |  | ✓  |  | ✓  |  |
| <b>Controls</b>                    | Digital-Analog   | Guiding Light Controls   | Digital-Analog   | Guiding Light Controls   | Digital-Analog   | Guiding Light Controls   |
| <b>Dual Convection</b>             | ✓  | ✓  | ✓  | ✓  | ✓  | ✓  |
| <b>Rapid Preheat</b>               | ✓  | ✓  | ✓  | ✓  | ✓  | ✓  |
| <b>Cleaning</b>                    | Hybrid Clean & Self-Clean (Oven)   | Hybrid Clean & Self-Clean (Oven)   | Hybrid Clean & Self-Clean  | Hybrid Clean & Self-Clean  | Hybrid Clean & Self-Clean  | Hybrid Clean & Self-Clean  |
| <b>Door Design</b>                 | Soft Open (MWO), Soft Close (Oven)   | Soft Open (MWO)  | Soft Close Door  |  | Soft Close Door  |  |
| <b>Racks</b>                       | 3 Heavy-Duty including<br>1 Gliding Rack   | 3 Heavy-Duty including<br>1 Gliding Rack   | 6 Heavy-Duty including<br>2 Gliding Racks  | 6 Heavy-Duty including<br>1 Gliding Rack   | 3 Heavy-Duty including<br>1 Gliding Rack   | 3 Heavy-Duty including<br>1 Gliding Rack   |
| <b>Additional Features</b>         | Temperature Probe, LED Spotlights,<br>LCD Display,<br>Easy View Window                                   | Temperature Probe, LED Spotlights,<br>Easy View Window   | Temperature Probe, LED Spotlights,<br>LCD Display,<br>Easy View Window                                   | Temperature Probe, LED Spotlights,<br>Easy View Window   | Temperature Probe,<br>LED Spotlights, LCD Display,<br>Easy View Window                                   | Temperature Probe, LED Spotlights,<br>Easy View Window   |
| <b>ADA Compliant</b>               |  |  |  |  | ✓  | ✓  |
| <b>Sabbath Mode</b>                | ★  | ★  | ★  | ★  | ★  | ★  |
| <b>Door Handles</b>                | Polygon  | Polygon  | Polygon  | Polygon  | Polygon  | Polygon  |
| <b>Power Ratings</b>               | 240V / 9.5 kW / 40 Amps<br>208V / 7.2 kW / 40 Amps   | 240V / 8.2 kW / 40 Amps<br>208V / 6.1 kW / 30 Amps   | 240V / 10.6 kW / 50 Amps<br>208V / 8.0 kW / 40 Amps  | 240V / 9.3 kW / 40 Amps<br>208V / 7.0 kW / 40 Amps   | 240V / 6.2 kW / 30 Amps<br>208V / 4.7 kW / 30 Amps   | 240V / 4.9 kW / 30 Amps<br>208V / 3.7 kW / 20 Amps   |
| <b>Color Options</b>               | Stainless, Black Stainless*  | Stainless, Black Stainless*  | Stainless, Black Stainless*  | Stainless, Black Stainless*  | Stainless, Black Stainless*  | Stainless, Black Stainless*  |
| <b>Oven Interior Color Options</b> | Blue   | Blue   | Blue   | Blue   | Blue   | Blue   |
| <b>Cut-Out Dimensions (WxHxD)</b>  | 28 <sup>1</sup> / <sub>2</sub> " x 42 <sup>1</sup> / <sub>4</sub> " x 23 <sup>1</sup> / <sub>2</sub> "   | 28 <sup>1</sup> / <sub>2</sub> " x 42 <sup>1</sup> / <sub>4</sub> " x 23 <sup>1</sup> / <sub>2</sub> "   | 28 <sup>1</sup> / <sub>2</sub> " x 50 <sup>1</sup> / <sub>4</sub> " x 23 <sup>1</sup> / <sub>2</sub> "   | 28 <sup>1</sup> / <sub>2</sub> " x 50 <sup>1</sup> / <sub>4</sub> " x 23 <sup>1</sup> / <sub>2</sub> "   | 28 <sup>1</sup> / <sub>2</sub> " x 27 <sup>1</sup> / <sub>4</sub> " x 23 <sup>1</sup> / <sub>2</sub> "   | 28 <sup>1</sup> / <sub>2</sub> " x 27 <sup>1</sup> / <sub>4</sub> " x 23 <sup>1</sup> / <sub>2</sub> "   |
| <b>Outside Dimensions (WxHxD)</b>  | 29 <sup>7</sup> / <sub>8</sub> " x 43 <sup>1</sup> / <sub>4</sub> " x 25 <sup>11</sup> / <sub>16</sub> " | 29 <sup>7</sup> / <sub>8</sub> " x 43 <sup>1</sup> / <sub>4</sub> " x 25 <sup>11</sup> / <sub>16</sub> " | 29 <sup>7</sup> / <sub>8</sub> " x 51 <sup>3</sup> / <sub>8</sub> " x 25 <sup>11</sup> / <sub>16</sub> " | 29 <sup>7</sup> / <sub>8</sub> " x 51 <sup>3</sup> / <sub>8</sub> " x 25 <sup>11</sup> / <sub>16</sub> " | 29 <sup>7</sup> / <sub>8</sub> " x 28 <sup>5</sup> / <sub>8</sub> " x 25 <sup>11</sup> / <sub>16</sub> " | 29 <sup>7</sup> / <sub>8</sub> " x 28 <sup>5</sup> / <sub>8</sub> " x 25 <sup>11</sup> / <sub>16</sub> " |

\*Fingerprint-resistant finish



# Built-In Cooking

## Cooktops – Induction | Electric





| Model                                 | NZ36K7880   | NZ30K7880   | NZ36K7570  | NZ30K7570  | NZ36K6430   | NZ30K6330   |
|---------------------------------------|---|---|--|--|---|---|
| <b>Platform</b>                       | 36" Induction   | 30" Induction   | 36" Electric   | 30" Electric   | 36" Electric  | 30" Electric  |
| <b>Flex Zone</b>                      | ✓   | ✓   |  |  |   |   |
| <b>Virtual Flame™</b>                 | ✓   | ✓   |  |  |   |   |
| <b>Wi-Fi Connectivity</b>             | ✓   | ✓   | ✓  | ✓  | ✓   | ✓   |
| <b>Bluetooth® Hood Connectivity</b>   | ✓   | ✓   | ✓  | ✓  |   |   |
| <b>Sync Elements</b>                  | ✓   | ✓   | ✓  | ✓  |   |   |
| <b>Rapid Boil™</b>                    |   |   | ✓  | ✓  | ✓   | ✓   |
| <b>Controls</b>                       | Digital Touch + Magnetic Knob   | Digital Touch + Magnetic Knob   | Digital Touch + Magnetic Knob  | Digital Touch + Magnetic Knob  | Analog Control  | Analog Control  |
| <b>Cooktop</b>                        | 5 Elements:<br>2 - Flex Zone – 1.8/2.6 kW Boost,<br>8" – 2.2/3.2 kW Boost,<br>6" – 1.4/1.8 kW Boost,<br>7"/11" – 3.6/4.8 kW Boost | 4 Elements:<br>2 - Flex Zone – 1.8/2.6 kW Boost,<br>6" – 1.4/1.8 kW Boost,<br>7"/11" – 3.6/4.8 kW Boost | 5 Elements:<br>2 - 7" – 1.5 kW (Sync)<br>6" – 1.2 kW (Melt)<br>12"/9"/6" – 3 kW<br>9"/6" – 3.3 kW (Simmer & Rapid Boil™) | 5 Elements:<br>2 - 7" – 1.5 kW (Sync)<br>8"/5" – 2 kW<br>6" – 1.2 kW (Melt)<br>9"/6" – 3.3 kW (Simmer & Rapid Boil™) | 5 Elements:<br>2 - 7" – 1.5 kW<br>6" – 1.2 kW (Melt)<br>12"/9"/6" – 3 kW<br>9"/6" – 3.3 kW (Simmer & Rapid Boil™) | 5 Elements:<br>2 - 7" – 1.5 kW<br>8"/5" – 2 kW<br>6" – 1.2 kW (Melt)<br>9"/6" – 3.3 kW (Simmer & Rapid Boil™) |
| <b>Total Power</b>                    | 10.8 kW   | 8.6 kW  | 10.5 kW  | 9.5 kW   | 10.5 kW   | 9.5 kW  |
| <b>Power Boost</b>                    | ✓   | ✓   |  |  |   |   |
| <b>Power Levels</b>                   | 15 + Boost  | 15 + Boost  | 15   | 15   |   |   |
| <b>Power Ratings</b>                  | 240V / 60 Hz / 45 Amps  | 240V / 60 Hz / 40 Amps  | 240V / 60 Hz / 40 Amps   | 240V / 60 Hz / 40 Amps   | 240V / 60 Hz / 40 Amps  | 240V / 60 Hz / 40 Amps  |
| <b>ADA Compliant</b>                  | ✓   | ✓   | ✓  | ✓  | ✓   | ✓   |
| <b>Color Options</b>                  | Stainless,<br>Black Stainless*  | Stainless,<br>Black Stainless*  | Stainless,<br>Black Stainless*   | Stainless,<br>Black Stainless*   | Stainless,<br>Black Stainless*  | Stainless,<br>Black Stainless*  |
| <b>Cut-Out Dimensions<br/>(WxHxD)</b> | 33 <sup>5</sup> / <sub>8</sub> " x 4" x 19 <sup>1</sup> / <sub>8</sub> "  | 28 <sup>1</sup> / <sub>2</sub> " x 4" x 19 <sup>4</sup> / <sub>8</sub> "                                | 33 <sup>5</sup> / <sub>8</sub> " x 5 <sup>1</sup> / <sub>10</sub> " x 19 <sup>1</sup> / <sub>8</sub> "                   | 28 <sup>1</sup> / <sub>2</sub> " x 5 <sup>1</sup> / <sub>10</sub> " x 19 <sup>4</sup> / <sub>8</sub> "               | 33 <sup>5</sup> / <sub>8</sub> " x 5 <sup>1</sup> / <sub>10</sub> " x 19 <sup>1</sup> / <sub>8</sub> "            | 28 <sup>1</sup> / <sub>2</sub> " x 5 <sup>1</sup> / <sub>10</sub> " x 19 <sup>4</sup> / <sub>8</sub> "        |
| <b>Outside Dimensions<br/>(WxHxD)</b> | 36" x 4" x 21 <sup>1</sup> / <sub>4</sub> "   | 30" x 4" x 21 <sup>1</sup> / <sub>4</sub> "   | 36" x 5 <sup>1</sup> / <sub>10</sub> " x 21 <sup>1</sup> / <sub>4</sub> "  | 30" x 5 <sup>1</sup> / <sub>10</sub> " x 21 <sup>1</sup> / <sub>4</sub> "  | 36" x 5 <sup>1</sup> / <sub>10</sub> " x 21 <sup>1</sup> / <sub>4</sub> "   | 30" x 5 <sup>1</sup> / <sub>10</sub> " x 21 <sup>1</sup> / <sub>4</sub> "                                     |

\*Fingerprint-resistant finish





# Built-In Cooking Cooktops – Gas





| Model                        | NA36N7755   | NA30N7755   | NA36N6555   | NA30N6555   |
|------------------------------|---|---|---|---|
| Platform                     | 36" Gas Cooktop   | 30" Gas Cooktop   | 36" Gas Cooktop   | 30" Gas Cooktop   |
| Power Burner                 | 22K True Dual Power Burner  | 22K True Dual Power Burner  | 19K Dual Power Burner   | 19K Dual Power Burner   |
| Wi-Fi Connectivity           | ✓   | ✓   | ✓   | ✓   |
| Bluetooth® Hood Connectivity | ✓   | ✓   |   |   |
| Controls                     | Digital-Analog  | Digital-Analog  | Blue LED Illuminated Knobs  | Blue LED Illuminated Knobs  |
| Cooktop                      | 5 Burners:<br>13K<br>9.5K<br>5K (Simmer)<br>9.5K<br>22K (True Dual Brass)                             | 5 Burners:<br>13K<br>9.5K<br>5K (Simmer)<br>9.5K<br>22K (True Dual Brass)                             | 5 Burners:<br>13K<br>9.5K<br>5K (Simmer)<br>9.5K<br>19K (Dual)  | 5 Burners:<br>13K<br>9.5K<br>5K (Simmer)<br>9.5K<br>19K (Dual)  |
| Total BTU                    | 59K   | 59K   | 56K   | 56K   |
| Power Ratings                | 120V / 60 Hz / 1 Amp  | 120V / 60 Hz / 1 Amp  | 120V / 60 Hz / 1 Amp  | 120V / 60 Hz / 1 Amp  |
| Blue LED Illuminated Knobs   | ✓<br>(Knurling Design)  | ✓<br>(Knurling Design)  | ✓   | ✓   |
| Cast Iron 3-Piece Grates     | ✓   | ✓   | ✓   | ✓   |
| Sealed Burners               | ✓   | ✓   | ✓   | ✓   |
| Additional Features          | Cast Iron Griddle, Wok Grate  | Cast Iron Griddle, Wok Grate  | Griddle   | Griddle   |
| ADA Compliant                | ✓   | ✓   | ✓   | ✓   |
| Color Options                | Stainless,<br>Black Stainless*  | Stainless,<br>Black Stainless*  | Stainless,<br>Black Stainless*  | Stainless,<br>Black Stainless*  |
| Cut-Out Dimensions (WxHxD)   | 33 <sup>7</sup> / <sub>8</sub> " x 3 <sup>1</sup> / <sub>8</sub> " x 19 <sup>1</sup> / <sub>8</sub> " | 28 <sup>1</sup> / <sub>2</sub> " x 3 <sup>1</sup> / <sub>8</sub> " x 19 <sup>5</sup> / <sub>8</sub> " | 33 <sup>7</sup> / <sub>8</sub> " x 3 <sup>1</sup> / <sub>8</sub> " x 19 <sup>1</sup> / <sub>8</sub> " | 28 <sup>1</sup> / <sub>2</sub> " x 3 <sup>1</sup> / <sub>8</sub> " x 19 <sup>5</sup> / <sub>8</sub> " |
| Outside Dimensions (WxHxD)   | 36" x 5 <sup>41</sup> / <sub>32</sub> " x 22 <sup>1</sup> / <sub>3</sub> "                            | 30" x 5 <sup>41</sup> / <sub>32</sub> " x 22 <sup>1</sup> / <sub>3</sub> "                            | 36" x 5 <sup>41</sup> / <sub>32</sub> " x 22 <sup>1</sup> / <sub>3</sub> "                            | 30" x 5 <sup>41</sup> / <sub>32</sub> " x 22 <sup>1</sup> / <sub>3</sub> "                            |

\*Fingerprint-resistant finish





SAMSUNG

# Ranges

Download Spec Sheets and Line Drawings at [samsung.com/builder](https://samsung.com/builder)





## Flex Duo™

A removable Smart Divider and dual temperature controls allow you to choose between two ovens or one.

## Dual Door™

Unique middle-hinged door can open just the top section or the full oven for total flexibility and energy efficiency.



## Blue LED Illuminated Knobs

Visually lets you know if your cooktop is on, even at a distance.



## NE58K9560WS

5.8 cu. ft. Virtual Flame™ Technology  
Slide-In Induction Range

Available Color



Stainless Steel  
NE58K9560WS/AA

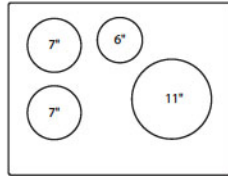

### Virtual Flame™ Technology

LED surface lights shine onto pots and pans to give you the visual of gas cooking with the precision of induction cooking.

### Dual Convection

Circulates air for more even and efficient cooking results.

### Slide-In Design

Modern and sleek built-in look that blends seamlessly with your kitchen.

### Glass Touch Controls

Seamless, integrated and premium design that is easy to clean.

### Wi-Fi Connectivity

Remotely monitor your cooktop and control your oven.



## NY58J9850WS

5.8 cu. ft. Flex Duo™ with Dual Door™ Slide-In  
Dual Fuel Range

Available Color



Stainless Steel  
NY58J9850WS/AA

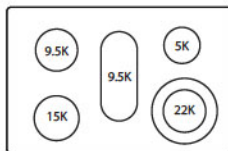

### Dual Fuel

Samsung's first combination gas cooktop and electric oven provides the best of both worlds for precision and efficiency. And the gas cooktop offers powerful, even and precise heating.

### Flex Duo™

A removable Smart Divider and dual temperature controls allow you to choose between two ovens or one.

### Dual Door™

A hinged door gives you access to just the top compartment or the full oven for total flexibility and energy efficiency.

### 22K BTU True Dual Power Burner

Two independent heating elements with power ranging from high heat to a true simmer.

### Dual Convection

Circulates air for more even and efficient cooking results.



# NE58K9850

5.8 cu. ft. Flex Duo™ with Dual Door™ Slide-In Electric Range



### Available Colors



Fingerprint Resistant Black Stainless Steel  
NE58K9850WG/AA



Stainless Steel  
NE58K9850WS/AA

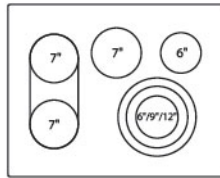

### Flex Duo™

A removable Smart Divider and dual temperature controls allow you to choose between two ovens or one.

### Dual Door™

A hinged door gives you access to just the top compartment or the full oven for total flexibility and energy efficiency.

### Blue LED Illuminated Knobs

Visually lets you know if your cooktop is on, even at a distance.

### Soft-Close Door

Gently closes oven door.

### Wi-Fi Connectivity

Remotely monitor your cooktop and control your oven.

# NE58F9710WS

5.8 cu. ft. Flex Duo™ Slide-In Electric Range

### Available Color



Stainless Steel  
NE58F9710WS/AA

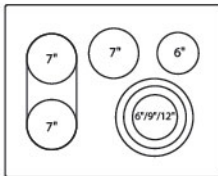

### Flex Duo™

A removable Smart Divider and dual temperature controls allow you to choose between two ovens or one.

### Dual Convection

Circulates air for more even and efficient cooking results.

### Powerful, Flexible Cooktop

Five elements, including a triple ring and bridge element, accommodate multiple pan sizes.

### Guiding Light Controls

Step-by-step controls make it easy to select oven options.

### Temperature Probe

Built-in probe allows you to monitor the temperature so you never have to guess whether your meats and poultry are cooked properly.



## NE58K9500SG/NE58F9500SS

5.8 cu. ft. Dual Convection Slide-In Electric Range

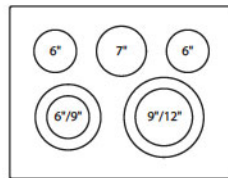

### 5.8 cu. ft. Capacity

Cook multiple dishes at once or accommodate larger items for the holidays.

### Dual Convection

Circulates air with a heated fan system for more even and efficient cooking results.

### Powerful, Flexible Cooktop

Five elements, including two dual-ring elements, accommodate multiple pan sizes.

### Temperature Probe

Built-in probe allows you to monitor the temperature so you never have to guess whether your meats and poultry are cooked properly.

### Guiding Light Controls

Step-by-step controls make it easy to select oven options.

## NE58N9430SG/NE58K9430SS

5.8 cu. ft. Convection Slide-In Electric Range

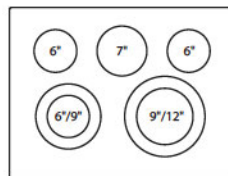

### 5.8 cu. ft. Capacity

Cook multiple dishes at once or accommodate larger items for the holiday.

### Dual Convection

Circulates air for faster, more even and efficient cooking.

### Powerful, Flexible Cooktop

Five elements, including two dual-ring elements, accommodate multiple pan sizes.

### Glass Touch Controls

Seamless, integrated and premium design that is easy to clean.



# NX58K9850

5.8 cu. ft. Flex Duo™ with Dual Door™ Slide-In Gas Range

### Available Colors



Fingerprint Resistant Black Stainless Steel  
NX58K9850SG/AA



Stainless Steel  
NX58K9850SS/AA

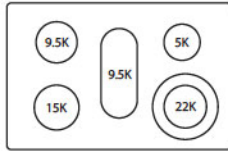

### Flex Duo™

A removable Smart Divider and dual temperature controls allow you to choose between two ovens or one.

### Dual Door™

A hinged door gives you access to just the top compartment or the full oven for total flexibility and energy efficiency.

### Blue LED Illuminated Knobs

Visually lets you know if your cooktop is on, even at a distance.

### 22K BTU True Dual Power Burner

Two independent heating elements with power ranging from high heat to a true simmer.

### Wi-Fi Connectivity

Remotely monitor your cooktop and control your oven.

# NX58K9500

5.8 cu. ft. True Convection Slide-In Gas Range

### Available Colors



Fingerprint Resistant Black Stainless Steel  
NX58K9500WG/AA



Stainless Steel  
NX58H9500WS/AA

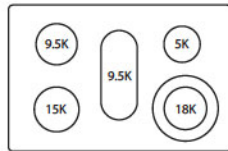

### True Convection

Cook food faster and more evenly with a heated fan system that is great for baking and broiling.

### 18K BTU True Dual-Power Burner

Two independent heating elements with power ranging from high heat to a true simmer.

### Reversible Cast Iron Griddle

Cook a variety of breakfast foods or grilled sandwiches on the reversible cast iron griddle.

### Guiding Light Controls

Step-by-step controls make it easy to select oven options.

### Temperature Probe

Built-in probe allows you to monitor the temperature so you never have to guess whether your meats and poultry are cooked properly.





# NX58N9420SG/NX58M9420SS

5.8 cu. ft. Convection Slide-In Gas Range



## Available Colors



Fingerprint  
Resistant Black  
Stainless Steel  
NX58N9420SG/AA



Stainless Steel  
NX58M9420SS/AA

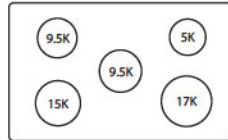

## Fan Convection

Circulates air for faster, more even cooking.

## Powerful, Flexible Cooktop

Flexible cooktop cooks faster with five specialized round burners and a 17K BTU Power Burner.

## Glass Touch Controls

Seamless, integrated and premium design that is easy to clean.

## Wi-Fi Connectivity

Remotely monitor your cooktop and control your oven.



## NE59J7850

5.9 cu. ft. Flex Duo™ with Dual Door™ Freestanding Electric Range

### Available Colors



Fingerprint Resistant Black Stainless Steel  
NE59J7850WG/AA



Stainless Steel  
NE59J7850WS/AA

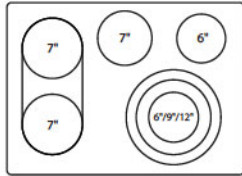

### Warming Drawer

Keep food warm until guests arrive or dinner is served.

### Flex Duo™

A removable Smart Divider and dual temperature controls allow you to choose between two ovens or one.

### Dual Door™

A hinged door gives you access to just the top compartment or the full oven for total flexibility and energy efficiency.

### Dual Convection

Circulates air with a heated fan system for more even and efficient cooking results.

### Powerful, Flexible Cooktop

Five elements, including a bridge and a triple ring element, accommodate multiple pan sizes.

### Soft-Close Door

Keep the kitchen quiet with soft-close door technology that will catch the door for a whisper-quiet close.

## NE59M6850

5.9 cu. ft. Flex Duo™ with Dual Door™ Freestanding Electric Range

### Available Colors



Fingerprint Resistant Black Stainless Steel  
NE59M6850SG/AA



Stainless Steel  
NE59M6850SS/AA

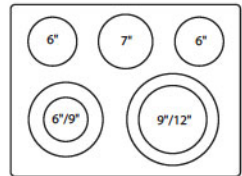

### Flex Duo™

A removable Smart Divider and dual temperature controls allow you to choose between two ovens or one.

### Dual Door™

A hinged door gives you access to just the top compartment or the full oven for total flexibility and energy efficiency.

### Dual Convection

Two fans circulate air for faster, more even, and efficient cooking.

### Powerful, Flexible Cooktop

Flexible cooktop cooks faster with five specialized elements and two dual elements.

### Soft-Close Door

Keep the kitchen quiet with soft-close door technology that will catch the door for a whisper-quiet close.

### 5.9 cu. ft. Large Capacity

Cook multiple dishes at once or accommodate larger items for the holidays.



## NE59N6630

5.9 cu. ft. True Convection Freestanding Electric Range

### Available Colors



Fingerprint Resistant Black Stainless Steel  
NE59N6630SG/AA



Stainless Steel  
NE59N6630SS/AA

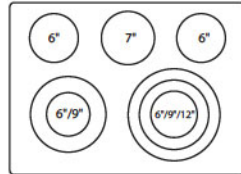

### True Convection

Cook food faster and more evenly with a heated fan system that is great for baking and broiling.

### Powerful, Flexible Cooktop

Dual and triple ring elements offer flexibility in cooking.

### Rapid Boil™

Offers intense heat and precise control. Rapidly go from a low simmer to high heat with surprising energy efficiency.

### 5.9 cu. ft. Large Capacity

Cook multiple dishes at once or accommodate larger items for the holidays.

### Touch Control

Wider touch control panel feels like glass and provides easy control and visibility of oven and clock settings.

## NE59N6650

5.9 cu. ft. True Convection with Illuminated Knobs Freestanding Electric Range

### Available Colors



Fingerprint Resistant Black Stainless Steel  
NE59N6650SG/AA



Stainless Steel  
NE59N6650SS/AA

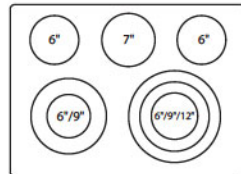

### True Convection

Cook food faster and more evenly with a heated fan system that is great for baking and broiling.

### Powerful, Flexible Cooktop

Dual and triple ring elements offer flexibility in cooking.

### Blue LED Illuminated Knobs

Visually lets you know if your cooktop is on, even at a distance.

### Steam Assist

Delivers moisture throughout the over for a tender inside and a crisp, browned outside.

### Express Boil™

Samsung's most powerful heat source for boiling water.



# NE59M4320

5.9 cu. ft. Convection Freestanding Electric Range

**Available Colors**

|  |   |   |   |
|--|---|---|---|
|  |  |  |  |
| Fingerprint Resistant Black Stainless Steel<br>NE59M4320SG/AA                    | Stainless Steel<br>NE59M4320SS/AA   | White<br>NE59M4320SW/AA   | Black<br>NE59M4320SB/AA   |

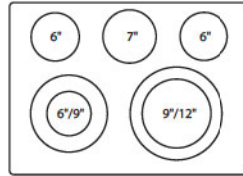

## 5.9 cu. ft. Large Capacity

Cook multiple dishes at once or accommodate larger items for the holidays.

## Fan Convection

Circulates air for faster, more even cooking.

## Stainless Steel Cooktop and Die-Cast Knobs

Premium look and larger cooking space for greater flexibility to use multiple pot and pan sizes.

## Powerful, Flexible Cooktop

Five elements with two dual elements accommodate multiple pan sizes.

## Dual Elements

One 6 7/9" and one 9 1/12" dual elements offer the flexibility to cook in different-sized pans.

# NE59M4310

5.9 cu. ft. Freestanding Electric Range

**Available Color**

|   |
|---|
|  |
| Stainless Steel<br>NE59M4310SS/AA   |

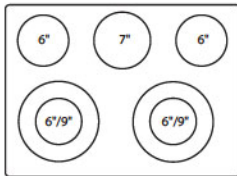

## 5.9 cu. ft. Large Capacity

Cook multiple dishes at once or accommodate larger items for the holidays.

## Powerful, Flexible Cooktop

Accommodates multiple pan sizes on five specialized elements with two dual elements.

## Dual Elements

Two 6 7/9" offer the flexibility to cook in different-sized pans.

## Self Clean

Cycle with 2-, 3- or 5-hour settings for various cleaning needs.

## Wide View Window

Check cooking progress without opening the door and losing heat.





## NX58K7850

5.8 cu. ft. Flex Duo™ with Dual Door™ Freestanding Gas Range

### Available Colors



Fingerprint Resistant Black Stainless Steel  
NX58K7850SG/AA



Stainless Steel  
NX58K7850SS/AA

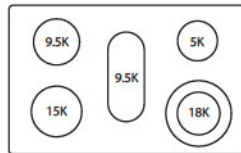

### Flex Duo™

A removable Smart Divider and dual temperature controls allow you to choose between two ovens or one.

### Dual Door™

A hinged door gives you access to just the top compartment or the full oven for total flexibility and energy efficiency.

### Dual Convection

Circulates air with a heated fan system for more even and efficient cooking results.

### Soft-Close Door

Gently closes oven door.

### Wi-Fi Connectivity

Remotely monitor your cooktop and control your oven.

## NX58M6850

5.8 cu. ft. Flex Duo™ with Dual Door™ Freestanding Gas Range

### Available Colors



Fingerprint Resistant Black Stainless Steel  
NX58M6850SG/AA



Stainless Steel  
NX58M6850SS/AA

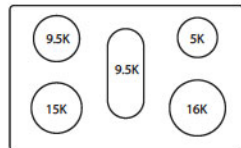

### Flex Duo™

A removable Smart Divider and dual temperature controls allow you to choose between two ovens or one.

### Dual Door™

A hinged door gives you access to just the top compartment or the full oven for total flexibility and energy efficiency.

### Dual Fan Convection

Circulates air for faster, more even, and efficient cooking.

### Powerful, Flexible Cooktop

Cooks faster with five specialized round burners, including 16K BTU and 15K BTU power burners.

### Wi-Fi Connectivity

Remotely monitor your cooktop and control your oven.



## NX58M6650

5.8 cu. ft. True Convection with Steam Reheat and Illuminated Knobs Freestanding Gas Range

### Available Colors



Fingerprint Resistant Black Stainless Steel  
NX58M6650WG/AA



Stainless Steel  
NX58M6650WS/AA

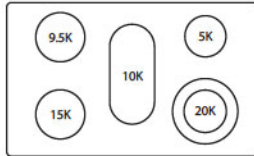

### 5.8 cu. ft. Large Capacity

Cook multiple dishes at once or accommodate larger items for the holidays.

### True Convection

Cook food faster and more evenly with a heated fan system that is great for baking and broiling.

### 20K BTU Dual Power Burner

Two independent heating elements with power ranging from high heat to a true simmer.

### Steam Reheat

Maintains your food's original flavor, texture and moisture.

### Blue LED Illuminated Knobs

Visually lets you know if your cooktop is on, even at a distance.

## NX58M6630

5.8 cu. ft. True Convection with Illuminated Knobs Freestanding Gas Range

### Available Colors



Fingerprint Resistant Black Stainless Steel  
NX58M6630SG/AA



Stainless Steel  
NX58M6630SS/AA

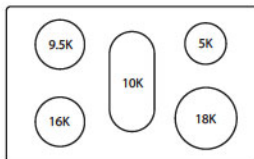

### Steam Reheat

Maintains your food's original flavor, texture and moisture.

### Blue LED Illuminated Knobs

Visually lets you know if your cooktop is on, even at a distance.

### Powerful, Flexible Cooktop

Cooks faster with five specialized burners, including 18K and 16K BTU power burners and one 5K simmer burner.

### True Convection

Cook food faster and more evenly with a heated fan system that is great for baking and broiling.

### 5.8 cu. ft. Large Capacity

Cook multiple dishes at once or accommodate larger items for the holidays.

### Touch Control

Wider touch control panel feels like glass, and provides easy control and visibility of oven and clock settings.



## NX58J/H/M5600

5.8 cu. ft. Convection Freestanding Gas Range

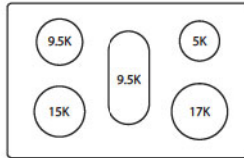

### 5.8 cu. ft. Capacity

Cook multiple dishes at once or accommodate larger items for the holidays.

### Fan Convection

Circulates air for faster, more even cooking.

### Powerful, Flexible Cooktop

Flexible cooktop cooks faster with five specialized burners.

### Stovetop Griddle

Griddle to cook breakfast foods, grill sandwiches or sauté vegetables.

## NX58K3310

5.8 cu. ft. Freestanding Gas Range

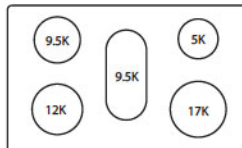

### 5.8 cu. ft. Capacity

Cook multiple dishes at once or accommodate larger items for the holidays.

### Powerful, Flexible Cooktop

Cook faster with 53K BTU on five burners simultaneously.

### 17K BTU Burner

Powerful burner boils water faster.

### Wide View Window

Check cooking progress without opening the door and losing heat.



Ranges  
Slide-In





Dual Fuel/Induction

Electric

Gas



| Model                  | NY58J9850WS  | NE58K9560WS   | NE58K9850  | NE58F9710WS  | NE58K9500SG/<br>NE58F9500SS   | NE58N9430SG/<br>NE58K9430SS   | NX58K9850  | NX58K9500  | NX58N9420SG/<br>NX58M9420SS  |
|------------------------|--|---|--|--|---|---|--|--|--|
| Capacity               | 5.8 cu. ft.  | 5.8 cu. ft.   | 5.8 cu. ft.  | 5.8 cu. ft.  | 5.8 cu. ft.   | 5.8 cu. ft.   | 5.8 cu. ft.  | 5.8 cu. ft.  | 5.8 cu. ft.  |
| Wi-Fi Connectivity     |  | ✓   | ✓  |  |   |   | ✓  |  | ✓  |
| Cooktop                | 5 Burners:<br>22K BTU (Dual Brass Burner)<br>15K<br>9.5K (Utility)<br>9.5K (Oval Center)<br>5K (Simmer)    | 4 Element Induction<br>Cooktop:<br>Single (11")<br>Single (6")<br>2 - Single (7") | 5 Elements:<br>Triple 6/9/12"<br>2 - Bridged 7"<br>Single 6"<br>Warm Center 7" | 5 Elements:<br>Triple 6/9/12"<br>2 - Bridged 7"<br>Single 6"<br>Warm Center 7" | 5 Elements:<br>Dual 9/12"<br>Dual 6/9"<br>2 - Single 6"<br>Warm Center 7"   | 5 Elements:<br>Dual 9/12"<br>1 Dual 6/9"<br>2 - single 6"<br>Warm Center 7" | 5 Burners:<br>22K (True Dual)<br>15K<br>9.5K (Utility)<br>9.5K (Oval)<br>5K (Simmer)                       | 5 Burners:<br>18K (Dual)<br>15K<br>9.5K (Utility)<br>9.5K (Oval)<br>5k (Simmer)                            | 5 Burners:<br>17K Power Burner<br>15K<br>9.5K (Utility)<br>9.5K (Round)<br>5K (Simmer)                     |
| Flex Duo™              | ✓  |   | ✓  | ✓  |   |   | ✓  |  |  |
| Controls               | Guiding Light<br>w/ Diecast Knobs  | Guiding Light   | Guiding Light w/ Blue<br>LED Illuminated Knobs                                 | Guiding Light<br>w/ Diecast Knobs  | Guiding Light<br>w/ Diecast Knobs   | Glass-Touch<br>w/ Diecast Knobs   | Guiding Light w/ Blue<br>LED Illuminated Knobs   | Guiding Light<br>w/ Diecast Knobs  | Glass Touch<br>w/ Diecast Knobs  |
| Convection             | Dual Convection  | Dual Convection   | Dual Convection  | Dual Convection  | Dual Convection   | Dual Convection   | Dual Convection  | True Convection  | Fan Convection   |
| Total BTU              | 61K  |   |  |  |   |   | 61K  | 57K  | 56K  |
| Cleaning               | Self-Clean   | Self & Steam-Clean  | Self & Steam-Clean   | Self & Steam-Clean   | Self & Steam-Clean  | Self & Steam-Clean  | Self-Clean   | Self-Clean   | Self-Clean   |
| Door Design            | Dual Door™ w/ Soft Close   | Wide View Door  | Dual Door™ w/ Soft-Close   | Wide View Door   | Wide View Door  | Wide View Door  | Dual Door™ w/ Soft-Close   | Wide View Door   | Wide View Door   |
| Racks                  | 3 including 1 Gliding<br>and 1 Split Rack  | 3 including<br>1 Recessed and 1<br>Split Rack                                     | 3 including<br>1 Gliding   | 3 including 1 Gliding<br>and 1 Split Rack                                      | 3 including<br>1 Split Rack   | 2   | 3 including<br>1 Split Rack  | 3 including<br>1 Split Rack  | 2  |
| Warming Drawer         | ✓  | ✓   | ✓  | ✓  |   |   |  | ✓  |  |
| Additional Accessories | Temp. Probe, Griddle,<br>Wok Grate   |   | Temp. Probe  | Temp. Probe  | Temp. Probe   |   | Temp. Probe,<br>Reversible<br>Cast Iron Griddle,<br>Wok Grate  | Temp. Probe,<br>Reversible<br>Cast Iron Griddle,<br>Wok Grate  | Aluminum Griddle,<br>Wok Grate   |
| ADA Compliant          | ✓  | ✓   | ✓  | ✓  | ✓   | ✓   | ✓  | ✓  | ✓  |
| Sabbath Mode           | ★  | ★   | ★  | ★  | ★   | ★   | ★  | ★  | ★  |
| Door Handles           | Standard Round   | Standard Round  | Standard Round   | Standard Round   | Standard Round  | Standard Round  | Standard Round   | Standard Round   | Standard Round   |
| Power Ratings          | 240V / 60 Hz / 40 Amps   | 240V / 60 Hz / 40 Amps  | 240V / 60 Hz / 40 Amps   | 240V / 60 Hz / 40 Amps   | 240V / 60 Hz / 40 Amps  | 240V / 60 Hz / 40 Amps  | 120V / 60 Hz / 20 Amps   | 120V / 60 Hz / 20 Amps   | 120V / 60 Hz / 20 Amps   |
| Color Options          | Stainless  | Stainless   | Stainless,<br>Black Stainless*   | Stainless  | Stainless (F),<br>Black Stainless* (K)                                      | Stainless (K),<br>Black Stainless* (N)                                      | Stainless,<br>Black Stainless*   | Stainless (H),<br>Black Stainless* (K)   | Stainless (M),<br>Black Stainless* (N)   |
| Dimensions (WxHxD)     | 29 <sup>15</sup> / <sub>16</sub> " x 36 <sup>1</sup> / <sub>4</sub> " x 28 <sup>11</sup> / <sub>16</sub> " | 29 <sup>15</sup> / <sub>16</sub> " x 36" x 28 <sup>5</sup> / <sub>8</sub> "       | 29 <sup>15</sup> / <sub>16</sub> " x 36" x 28 <sup>5</sup> / <sub>8</sub> "    | 29 <sup>15</sup> / <sub>16</sub> " x 36" x 28 <sup>5</sup> / <sub>8</sub> "    | 29 <sup>15</sup> / <sub>16</sub> " x 36" x 28 <sup>5</sup> / <sub>8</sub> " | 29 <sup>15</sup> / <sub>16</sub> " x 36" x 28 <sup>5</sup> / <sub>8</sub> " | 29 <sup>15</sup> / <sub>16</sub> " x 36 <sup>1</sup> / <sub>4</sub> " x 28 <sup>11</sup> / <sub>16</sub> " | 29 <sup>15</sup> / <sub>16</sub> " x 36 <sup>1</sup> / <sub>4</sub> " x 28 <sup>11</sup> / <sub>16</sub> " | 29 <sup>15</sup> / <sub>16</sub> " x 36 <sup>1</sup> / <sub>4</sub> " x 28 <sup>11</sup> / <sub>16</sub> " |

\*Fingerprint-resistant finish



# Ranges

## Freestanding



Electric

Gas



| Model               | NE59J7850   | NE59M6850   | NE59N6650   | NE59N6630  | NE59M4320   | NE59M4310   | NX58K7850   | NX58M6850   | NX58M6650   | NX58M6630   | NX58H/J/M5600   | NX58K3310   |  |
|---------------------|---|---|---|--|---|---|---|---|---|---|---|---|--|
| Capacity            | 5.9 cu. ft.   | 5.9 cu. ft.   | 5.9 cu. ft.   | 5.9 cu. ft.  | 5.9 cu. ft.   | 5.9 cu. ft.   | 5.8 cu. ft.   | 5.8 cu. ft.   | 5.8 cu. ft.   | 5.8 cu. ft.   | 5.8 cu. ft.   | 5.8 cu. ft.   |  |
| Wi-Fi Connectivity  |   | ✓   | ✓   |  |   |   | ✓   | ✓   | ✓   |   |   |   |  |
| Cooktop             | 5 Elements:<br>Triple 6/9/12"<br>2- Bridged 7"<br>Single 6"<br>Warm Center 7"                           | 5 Elements:<br>Dual 9/12"<br>Dual 6/9"<br>2- Single 6"<br>Warm Center 7"                                | 5 Elements:<br>Triple 6/9/12"<br>(3kW Fast Boil)<br>Double 6/9"<br>(3.6kW Express Boil)<br>2- Single 6"<br>Warm Center 7" | 5 Elements:<br>Triple 6/9/12"<br>(3kW Fast Boil)<br>Double 6/9"<br>(3.3kW Rapid Boil™)<br>2- Single 6"<br>Warm Center 7" | 5 Elements:<br>Dual 9/12"<br>Dual 6/9"<br>2- Single 6"<br>Warm Center 7"                                | 5 Elements:<br>2- Dual 6/9"<br>2- Single 6"<br>Warm Center 7"   | 5 Elements:<br>2- Dual 6/9"<br>2- Single 6"<br>Warm Center 7"   | 5 Burners:<br>18K (Dual)<br>15K<br>9.5K (Utility)<br>9.5K (Oval)<br>5K Simmer                               | 5 Burners:<br>16K (Power)<br>15K<br>9.5K (Utility)<br>9.5K (Round)<br>5K (Simmer)                           | 5 Burners:<br>20K (Dual)<br>15K<br>9.5K (Utility)<br>10K (Oval)<br>5K (Simmer)                              | 5 Burners:<br>18K (Dual)<br>16K<br>9.5K (Utility)<br>10K (Oval)<br>5K (Simmer)                              | 5 Burners:<br>17K (Power)<br>15K<br>9.5K (Utility)<br>9.5K (Oval)<br>5K (Simmer)                            | 5 Burners:<br>17K (Power)<br>12K<br>9.5K (Utility)<br>9.5K (Oval)<br>5K (Simmer) |
| Flex Duo™           | Flex Duo™   | Flex Duo™ <sup>1</sup>  |   |  |   |   | Flex Duo™   | Flex Duo™ <sup>1</sup>  |   |   |   |   |  |
| Controls            | Diecast Knobs & Membrane  | Diecast Knobs & Membrane  | Blue LED Illuminated Knobs & Touch Control  | Diecast Knobs & Touch Control  | Diecast Knobs & Membrane  | Plastic Knobs & Membrane  | Diecast Knobs & Membrane  | Diecast Knobs & Membrane  | Blue LED Illuminated Knobs & Touch Control  | Blue LED Illuminated Knobs & Touch Control  | Diecast Knobs & Membrane  | Plastic Knobs & Membrane  |  |
| Convection          | Dual Convection   | Dual Fan Convection   | True Convection   | True Convection  | Fan Convection  |   | Dual Convection   | Dual Fan Convection   | True Convection   | True Convection   | Fan Convection  |   |  |
| Total BTU           |   |   |   |  |   |   | 57K   | 55K   | 59.5K   | 58.5K   | 56K   | 53K   |  |
| Cleaning            | Steam & Self-Clean  | Steam & Self-Clean  | Steam & Self-Clean  | Steam & Self-Clean   | Steam & Self-Clean  | Self-Clean  | Self-Clean  | Self-Clean  | Self-Clean  | Self-Clean  | Self-Clean  | Self-Clean  |  |
| Door Design         | Dual Door™ w/ Soft-Close  | Dual Door™ w/ Soft-Close  | Wide View Door  | Wide View Door   | Wide View Door  | Wide View Door  | Dual Door™ w/ Soft-Close  | Dual Door™ w/ Soft-Close  | Wide View Door  | Wide View Door  | Wide View Door  | Wide View Door  |  |
| Door Handles        | Standard Round  | Standard Round  | Standard Round  | Standard Round   | Standard Round  | Standard Round  | Standard Round  | Standard Round  | Standard Round  | Standard Round  | Standard Round  | Standard Round  |  |
| Racks               | 3 Including 1 Split Rack  | 3   | 3   | 3  | 2   | 2   | 3 Including 1 Gliding Rack  | 3   | 3 Including 1 Split Rack  | 2   | 2   | 2   |  |
| Warming Drawer      | ✓   |   |   |  |   |   |   |   | ✓   |   |   |   |  |
| Additional Features |   |   | Steam Assist  |  |   |   | Griddle, Wok Grate  |   | Steam Reheat, Griddle, Wok Grate  |   | Griddle   |   |  |
| Sabbath Mode        | ★   | ★   | ★   | ★  | ★   | ★   | ★   | ★   | ★   | ★   | ★   | ★   |  |
| Power Ratings       | 240V / 60 Hz / 40 Amps  | 240V / 60 Hz / 40 Amps  | 240V / 60 Hz / 40 Amps  | 240V / 60 Hz / 40 Amps   | 240V / 60 Hz / 40 Amps  | 240V / 60 Hz / 40 Amps  | 120V / 60 Hz / 20 Amps  | 120V / 60 Hz / 20 Amps  | 120V / 60 Hz / 20 Amps  | 120V / 60 Hz / 20 Amps  | 120V / 60 Hz / 20 Amps  | 120V / 60 Hz / 20 Amps  |  |
| Color Options       | Stainless, Black Stainless <sup>2</sup>   | Stainless, Black Stainless <sup>2</sup>   | Stainless, Black Stainless <sup>2</sup>   | Stainless, Black Stainless <sup>2</sup>  | Stainless, Black Stainless <sup>2</sup> , Black, White  | Stainless   | Stainless, Black Stainless <sup>2</sup>   | Stainless, Black Stainless <sup>2</sup>   | Stainless, Black Stainless <sup>2</sup>   | Stainless, Black Stainless <sup>2</sup>   | Stainless, Black Stainless <sup>2</sup> , Black, White  | Stainless   |  |
| Dimensions (WxHxD)  | 29 <sup>7</sup> / <sub>8</sub> " x 46 <sup>1</sup> / <sub>2</sub> " x 28 <sup>7</sup> / <sub>16</sub> " | 29 <sup>7</sup> / <sub>8</sub> " x 46 <sup>1</sup> / <sub>2</sub> " x 28 <sup>7</sup> / <sub>16</sub> " | 29 <sup>7</sup> / <sub>8</sub> " x 46 <sup>1</sup> / <sub>2</sub> " x 28 <sup>7</sup> / <sub>16</sub> "                   | 29 <sup>7</sup> / <sub>8</sub> " x 46 <sup>1</sup> / <sub>2</sub> " x 28 <sup>7</sup> / <sub>16</sub> "                  | 29 <sup>7</sup> / <sub>8</sub> " x 46 <sup>1</sup> / <sub>2</sub> " x 28 <sup>7</sup> / <sub>16</sub> " | 29 <sup>7</sup> / <sub>8</sub> " x 46 <sup>1</sup> / <sub>2</sub> " x 28 <sup>7</sup> / <sub>16</sub> " | 29 <sup>7</sup> / <sub>8</sub> " x 46 <sup>1</sup> / <sub>2</sub> " x 28 <sup>7</sup> / <sub>16</sub> " | 29 <sup>15</sup> / <sub>16</sub> " x 46 <sup>11</sup> / <sub>16</sub> " x 28 <sup>5</sup> / <sub>16</sub> " | 29 <sup>15</sup> / <sub>16</sub> " x 46 <sup>11</sup> / <sub>16</sub> " x 28 <sup>5</sup> / <sub>16</sub> " | 29 <sup>15</sup> / <sub>16</sub> " x 46 <sup>11</sup> / <sub>16</sub> " x 28 <sup>5</sup> / <sub>16</sub> " | 29 <sup>15</sup> / <sub>16</sub> " x 46 <sup>11</sup> / <sub>16</sub> " x 28 <sup>5</sup> / <sub>16</sub> " | 29 <sup>15</sup> / <sub>16</sub> " x 46 <sup>11</sup> / <sub>16</sub> " x 28 <sup>5</sup> / <sub>16</sub> " |  |

<sup>1</sup>No Flex Duo™ divider storage  
<sup>2</sup>Fingerprint-resistant finish







### Cooking Guide

- Smart Multi Sensor Cooking**
- Co-1. Beverage
- Co-2. Chicken breast
- Co-3. Frozen breakfast
- Co-4. Frozen dinner
- Reheat**
- Rh-1. Dinner plate
- Rh-2. Casserole
- Rh-3. Pasta
- Veggies**
- Fr-1. Fresh vegetables
- Fr-2. Frozen vegetables
- Cooking Presets**
- Fit Choice**
- FC-1. Spinach
- FC-2. Squash
- FC-3. Brown rice
- FC-4. Oatmeal
- FC-5. Quinoa
- FC-6. Bone in chicken pieces
- FC-7. Fresh fish fillets
- FC-8. Fresh salmon fillets
- FC-9. Fresh prawns
- Kids Meals**
- CH-1. Chicken nuggets
- CH-2. French fries
- CH-3. Frozen sandwiches
- CH-4. Hot dogs
- Snacks**
- Sn-1. Cheese sticks
- Sn-2. Chicken wings
- Sn-3. Nachos
- Sn-4. Potato skins
- Soften/Melt**
- St-1. Melt butter
- St-2. Melt chocolate
- St-3. Soften butter
- St-4. Soften cream cheese
- Smart Defrost**
- Smart Defrost**
- dF-1. Ground meat 0.5-0.9lbs
- dF-2. Ground meat 1-3lbs
- dF-3. Piece of meat 0.5-0.9lbs
- dF-4. Piece of meat 1-3lbs
- dF-5. Whole poultry
- dF-6. Piece of poultry
- dF-7. Fish fillet

\* The Filter cleaning indicator turns on when it needs to be cleaned. And when pressing '0', it turns off.



# Microwaves

Download Spec Sheets and Line Drawings at [samsung.com/builder](http://samsung.com/builder)





## Powerful Heat

Power convection technology heats evenly and cooks 30% faster than a standard convection microwave.

## PowerGrill

The PowerGrill feature lets you toast, crisp and brown your favorite foods.



## Black Stainless Steel

Clean and contemporary, a black stainless steel finish brings an added level of sophistication to your kitchen.

## MC17J8000

1.7 cu. ft. Over-the-Range  
Convection Microwave

### Available Colors



Fingerprint  
Resistant Black  
Stainless Steel  
MC17J8000CG/AA



Fingerprint  
Resistant  
Stainless Steel  
MC17J8000CS/AA



### Convection Cooking

Enjoy the flexibility to microwave, bake, broil and roast — all from one appliance. With the combination of convection cooking and microwave heating, food cooks faster and more evenly than a traditional microwave.<sup>1</sup>

### Ceramic Enamel Interior

Effortlessly remove grease or oil from surfaces and protect against scratches.

### Slim Fry™

Prepare great-tasting food with less fat.<sup>2</sup>

### Three-Speed/300 CFM

Powerful ventilation system quickly and quietly eliminates steam, fumes and odor from the kitchen.

<sup>1</sup>Fresh vegetables in less than two minutes. Roasted chicken in 14 minutes. Two potatoes will bake in 11 minutes.

<sup>2</sup>Compared to cooking with deep frying

## ME21K7010

2.1 cu. ft. PowerGrill Over-the-  
Range with Ceramic Enamel  
Interior and Glass Touch Controls

### Available Colors



Fingerprint  
Resistant Black  
Stainless Steel  
ME21K7010DG/AA



Fingerprint  
Resistant  
Stainless Steel  
ME21K7010DS/AA



### PowerGrill

Direct grilling element provides powerful heating to toast, crisp and brown your favorite food.

### Ceramic Enamel Interior

Effortlessly remove grease or oil from surfaces and protect against scratches.

### Sensor Cook

Automatically adjusts cooking time with vapor-sensing technology for optimal results.

### Glass Touch Bottom Controls

Seamless, integrated and premium design is easy to clean.

### LED Cooktop Lights

Evenly distributed bright lights illuminate the cooktop. More energy efficient and brighter than incandescent or halogen lights.



## ME21F707MJT

2.1 cu. ft. Over-the-Range Microwave

### Available Color



Fingerprint Resistant Stainless Steel  
ME21F707MJT/AA



### 2.1 cu. ft. Large Capacity

Accommodates a variety of snacks and meals.

### Ceramic Enamel Interior

Effortlessly remove grease or oil from surfaces and protect against scratches.

### Glass Touch Bottom Controls

Seamless, integrated and premium design is easy to clean.

### LED Cooktop Lights

Evenly distributed bright lights illuminate the cooktop. More energy efficient and brighter than incandescent or halogen lights.

### Simple-Clean Filter

Convenient, easy-to-access location is simple to eject with one touch and helps you remember when to clean the filter.

## ME21M706

2.1 cu. ft. Over-the-Range Microwave

### Available Colors



Fingerprint Resistant Black Stainless Steel  
ME21M706BAG/AA



Fingerprint Resistant Stainless Steel  
ME21M706BAS/AA



### Ceramic Enamel Interior

Effortlessly remove grease or oil from surfaces and protect against scratches.

### Sensor Cook

Automatically adjusts cooking time with vapor-sensing technology for optimal results.

### Glass Touch Bottom Controls

Glass touch provides precise controls with a seamless, integrated design.

### Recessed Handle

Seamless, integrated and modern design to match any kitchen.



## ME18H704

1.8 cu. ft. Over-the-Range Microwave



### 1.8 cu. ft. Capacity

Accommodates a variety of snacks and meals.

### Ceramic Enamel Interior

Effortlessly remove grease or oil from surfaces and protect against scratches.

### Sensor Cook

Automatically adjusts cooking time with vapor-sensing technology for optimal results.

### Simple-Clean Filter

Convenient, easy-to-access location is simple to eject with one touch and helps you remember when to clean the filter.

### Four-Speed/400 CFM

Powerful ventilation system quickly and quietly eliminates steam, fumes and odor from the kitchen.

## ME16H702

1.6 cu. ft. Over-the-Range Microwave



### 1.6 cu. ft. Capacity

Accommodates a variety of snacks and meals.

### Premium Design

One-piece door design with an aluminum handle and side control provides a seamless and modern look.

### LED Display

Striking blue LED display adds clarity and style to your kitchen.

### Eco Mode

Conserves energy by turning off the display when not in use.

### Two-Speed/300 CFM

Powerful ventilation system quickly and quietly eliminates steam, fumes and odor from the kitchen.





# ME16K3000

1.6 cu. ft. Over-the-Range  
Microwave

Available Color



Stainless Steel  
ME16K3000AS/AA



### **1.6 cu. ft. Capacity**

Accommodates a variety of snacks and meals.

### **Cooking Presets**

Preset cook modes for everyday dishes.

### **LED Display**

Striking blue LED display adds clarity and style to your kitchen.

### **Eco Mode**

Conserves energy by turning off the display when not in use.

### **Two-Speed/300 CFM**

Powerful ventilation system quickly and quietly eliminates steam, fumes and odor from the kitchen.



## MC12J8035CT

1.2 cu. ft. Countertop Microwave with Power Convection & PowerGrill Duo™

Available Color



Stainless Steel  
MC12J8035CT/AA



### Power Convection

Combines traditional convection cooking with powerful hot air coming from the top, distributing the heat thoroughly and cooking faster than a standard convection microwave oven.

### PowerGrill Duo™

Enjoy crisp food in minutes as the grill function works to brown and crisp your food outside without drying the inside. Its innovative wide grill heater delivers significantly more power, up to a maximum of 1600W.

### Ceramic Enamel Interior

Effortlessly remove grease or oil from surfaces and protect against scratches.

### Slim Fry™

Prepare great-tasting food with less fat.\*

### Microwave Trim Kit

Crafted from high-quality stainless steel, the MA-TK3080CT trim kit accessory (available for purchase) gives you the flexibility to install your MC12J8035CT countertop microwave into a wall or cabinet.

\*Compared to cooking with deep frying

## MC11K7035CG

1.1 cu. ft. Power Convection & PowerGrill Countertop Microwave with Ceramic Enamel Interior

Available Color



Fingerprint Resistant Black  
Stainless Steel  
MC11K7035CG/AA



### Power Convection

Combines traditional convection cooking with powerful hot air coming from the top, distributing the heat thoroughly and cooking faster than a standard convection microwave oven.

### PowerGrill

Direct grilling element provides powerful heating to toast, crisp and brown your favorite food.

### Ceramic Enamel Interior

Effortlessly remove grease or oil from surfaces and protect against scratches.

### Slim Fry™

Prepare great-tasting food with less fat.\*

### Sensor Cook

Automatically adjusts cooking time with vapor-sensing technology for optimal results.

\*Compared to cooking with deep frying



## MG14H3020CM

1.4 cu. ft. Countertop Microwave with PowerGrill

Available Color



Black with Mirror Finish  
MG14H3020CM/AA



### PowerGrill

Direct grilling element provides powerful heating to toast, crisp and brown your favorite food.

### Ceramic Enamel Interior

Effortlessly remove grease or oil from surfaces and protect against scratches.

### Triple Distribution System

Three microwave distribution points to cook food evenly and thoroughly.

### Round Rack and Ceramic Plate

Nonstick, easy-to-clean plate keeps your favorite foods crispy. Included rack provides optimal placement under the grill for crisping.

### Shiny Mirror Design

Shiny mirror design with asymmetrical shape for a premium look, differentiated from other countertop models.

## MG11H2020CT

1.1 cu. ft. Countertop Microwave with PowerGrill

Available Color



Stainless Steel  
MG11H2020CT/AA



### PowerGrill

Direct grilling element provides powerful heating to toast, crisp and brown your favorite food.

### Ceramic Enamel Interior

Effortlessly remove grease or oil from surfaces and protect against scratches.

### Triple Distribution System

Three microwave distribution points to cook food evenly and thoroughly.

### Round Rack and Ceramic Plate

Nonstick, easy-to-clean plate keeps your favorite foods crispy. Included rack provides optimal placement under the grill for crisping.

### 1000W Cooking Power

A cooking power of 1000 watts and 10 power levels allows you to cook a variety of foods more efficiently.



# MS19M8000

1.9 cu. ft. Countertop Microwave with Sensor Cook

### Available Colors



Fingerprint Resistant Black Stainless Steel  
MS19M8000AG/AA



Stainless Steel  
MS19M8000AS/AA



### 1.9 cu. ft. Capacity

Accommodates a variety of snacks and meals.

### Ceramic Enamel Interior

Effortlessly remove grease or oil from surfaces and protect against scratches.

### Sensor Cook

Automatically adjusts cooking time with vapor-sensing technology for optimal results.

### Microwave Trim Kit\*

Crafted from high-quality stainless steel, the trim kit accessory gives you the flexibility to install your countertop microwave into a wall or cabinet space.

**For installation with Wall Ovens, respective codes must be paired together:**

| Color                 | Product   | Model #     |
|-----------------------|-----------|-------------|
| Stainless Steel       | Microwave | MS19M8000AS |
| Stainless Steel       | Trim Kit  | MA-TK8020TS |
| Black Stainless Steel | Microwave | MS19M8020TG |
| Black Stainless Steel | Trim Kit  | MA-TK8020TG |

\* Sold separately

# MS19M8020

1.9 cu. ft. Built-In Countertop Microwave with Sensor Cook

### Available Color



Fingerprint Resistant Black Stainless Steel  
MS19M8020TG/AA



### 1.9 cu. ft. Capacity

Accommodates a variety of snacks and meals.

### Ceramic Enamel Interior

Effortlessly remove grease or oil from surfaces and protect against scratches.

### Sensor Cook

Automatically adjusts cooking time with vapor-sensing technology for optimal results.

### Microwave Trim Kit\*

Crafted from high-quality stainless steel, the trim kit accessory gives you the flexibility to install your countertop microwave into a wall or cabinet space.

**For installation with Wall Ovens, respective codes must be paired together:**

| Color                 | Product   | Model #     |
|-----------------------|-----------|-------------|
| Stainless Steel       | Microwave | MS19M8000AS |
| Stainless Steel       | Trim Kit  | MA-TK8020TS |
| Black Stainless Steel | Microwave | MS19M8020TG |
| Black Stainless Steel | Trim Kit  | MA-TK8020TG |

\* Sold separately





# MS14K6000

1.4 cu. ft. Countertop Microwave  
with Ceramic Enamel Interior and  
Sensor Cook

## Available Colors



Fingerprint  
Resistant Black  
Stainless Steel



Stainless Steel  
MS14K6000AS/AA

MS14K6000AG/AA



### **Ceramic Enamel Interior**

Effortlessly remove grease or oil from surfaces and protect against scratches.

### **Sensor Cook**

Automatically adjusts cooking time with vapor-sensing technology for optimal results.

### **Triple Distribution System**

Three microwave distribution points to cook food evenly and thoroughly.

### **LED Display**

Striking blue LED display adds clarity and style to your kitchen.

### **Eco Mode**

Conserves energy by turning off the display when not in use.



# Microwaves Over-The-Range





| Model                        | MC17J8000   | ME21K7010   | ME21F707MJT  | ME21M706  | ME18H704   | ME16H702  | ME16K3000  |
|------------------------------|---|---|--|---|--|---|--|
| <b>Capacity</b>              | 1.7 cu. ft.   | 2.1 cu. ft.   | 2.1 cu. ft.  | 2.1 cu. ft.   | 1.8 cu. ft.  | 1.6 cu. ft.   | 1.6 cu. ft.  |
| <b>Key Features</b>          | Convection Slim Fry™  | PowerGrill  | Glass Touch, Bottom Controls   | Recessed Handle, Fingerprint Resistant  | Ceramic Enamel   | Hidden Vent Tall Door   | Cooking Presets LED Display  |
| <b>Ventilation</b>           | 300 CFM   | 400 CFM   | 400 CFM  | 400 CFM   | 400 CFM  | 300 CFM   | 300 CFM  |
| <b>Cooking Power (Watts)</b> | 950 W (MW), 1790 W (Conv.)  | 1000 W, 1500 W (Grill)  | 1000 W   | 1000 W  | 1000 W   | 1000 W  | 1000 W   |
| <b>Sensor Cook</b>           |   | ✓   | ✓  | ✓   | ✓  |   |  |
| <b>Control Type</b>          | Membrane Bottom   | Glass Touch Bottom  | Glass Touch Bottom   | Glass Touch Bottom  | Membrane Side  | Membrane Side   | Membrane Side  |
| <b>Interior Material</b>     | Ceramic Enamel  | Ceramic Enamel  | Ceramic Enamel   | Ceramic Enamel  | Ceramic Enamel   | Epoxy   | Epoxy  |
| <b>Cooktop Lighting</b>      | Incandescent  | LED   | LED  | LED   | Halogen  | Incandescent  | Incandescent   |
| <b>Eco Mode</b>              | ✓   | ✓   | ✓  | ✓   | ✓  | ✓   | ✓  |
| <b>Filter</b>                | Standard  | Simple Clean Filter   | Simple Clean Filter  | Simple Clean Filter   | Simple Clean Filter  | Standard  | Standard   |
| <b>Door Handle</b>           | Standard Round  | Standard Round  | Standard Round   | Integrated  | Standard Round   | Standard Round  | Standard Round   |
| <b>Turntable On/Off</b>      | ✓   | ✓   | ✓  | ✓   | ✓  |   |  |
| <b>Recirculating Kit</b>     | ✓   | ✓   | ✓  | ✓   | ✓  | ✓   | ✓  |
| <b>Power Ratings</b>         | 120V / 60 Hz  | 120V / 60 Hz  | 120V / 60 Hz   | 120V / 60 Hz  | 120V / 60 Hz   | 120V / 60 Hz  | 120V / 60 Hz   |
| <b>Color Options</b>         | Stainless*, Black Stainless*  | Stainless*, Black Stainless*  | Stainless*   | Stainless*, Black Stainless*  | Stainless*, Black Stainless*, Black, White   | Stainless*, Black, White  | Stainless, Black, White  |
| <b>Dimensions (WxHxD)</b>    | 29 <sup>7</sup> / <sub>8</sub> " x 16 <sup>15</sup> / <sub>16</sub> " x 18 <sup>9</sup> / <sub>16</sub> " | 29 <sup>7</sup> / <sub>8</sub> " x 16 <sup>15</sup> / <sub>16</sub> " x 18 <sup>7</sup> / <sub>16</sub> " | 29 <sup>13</sup> / <sub>14</sub> " x 16 <sup>15</sup> / <sub>16</sub> " x 18 <sup>1</sup> / <sub>8</sub> " | 29 <sup>7</sup> / <sub>8</sub> " x 17 <sup>1</sup> / <sub>16</sub> " x 16 <sup>1</sup> / <sub>2</sub> " | 29 <sup>7</sup> / <sub>8</sub> " x 15 <sup>9</sup> / <sub>16</sub> " x 17 <sup>1</sup> / <sub>16</sub> " | 29 <sup>7</sup> / <sub>8</sub> " x 15 <sup>5</sup> / <sub>32</sub> " x 16 <sup>29</sup> / <sub>32</sub> " | 29 <sup>7</sup> / <sub>8</sub> " x 16 <sup>1</sup> / <sub>2</sub> " x 15 <sup>1</sup> / <sub>8</sub> " |

\*Fingerprint-resistant finish

# Microwaves Countertop







| Model                        | MC12J8035CT   | MC11K7035CG  | MG14H3020CM  | MG11H2020CT  | MS19M8000  | MS19M8020  | MS14K6000   |
|------------------------------|---|--|--|--|--|--|---|
| <b>Capacity</b>              | 1.2 cu. ft.   | 1.1 cu. ft.  | 1.4 cu. ft.  | 1.1 cu. ft.  | 1.9 cu. ft.  | 1.9 cu. ft.  | 1.4 cu. ft.   |
| <b>Key Features</b>          | PowerGrill Duo™, Power Conv., Drop Down Door  | Power Conv., PowerGrill, Drop Down Door  | PowerGrill   | PowerGrill   | Large Capacity, Sensor Cook, Trim-Kit Options Available <sup>1</sup>                                     | Built-in Application Microwave, Large Capacity, Trim-Kit Options Available <sup>1</sup>                  | Sensor Cook, Triple Dist. System  |
| <b>Cooking Power (Watts)</b> | 900 W, 1600 W PowerGrill Duo™, 1650 W Power Convection  | 1000 W, 1300 W PowerGrill, 1790 W Power Convection   | 950 W, 1300 W PowerGrill   | 1000 W, 1300 W PowerGrill  | 950 W  | 950 W  | 1000 W  |
| <b>Sensor Cook</b>           |   | ✓  |  | ✓  | ✓  | ✓  | ✓   |
| <b>Controls</b>              | Glass Touch   | Glass Touch, Dial  | Electronic Touch   | Electronic Touch   | Electronic Touch   | Electronic Touch   | Electronic Touch  |
| <b>Power Levels</b>          | 10  | 10   | 10   | 10   | 10   | 10   | 10  |
| <b>PowerGrill</b>            | ✓<br>(PowerGrill Duo™)  | ✓  | ✓  | ✓  |  |  |   |
| <b>Power Convection</b>      | ✓   | ✓  |  |  |  |  |   |
| <b>Interior Material</b>     | Ceramic Enamel  | Ceramic Enamel   | Ceramic Enamel   | Ceramic Enamel   | Ceramic Enamel   | Ceramic Enamel   | Ceramic Enamel  |
| <b>Turntable On/Off</b>      | ✓   | ✓  | ✓  | ✓  | ✓  | ✓  | ✓   |
| <b>Door Handle</b>           | Standard Round  | Integrated   | Integrated   | Integrated   | Integrated   | Integrated   | Integrated  |
| <b>Optional Trim Kit™</b>    | MA-TK3080CT   |  |  |  | MA-TK8020TS (Stainless)  | MA-TK8020TG (Black Stainless <sup>2</sup> )  |   |
| <b>Power Ratings</b>         | 120V / 60 Hz  | 120V / 60 Hz   | 120V / 60 Hz   | 120V / 60 Hz   | 120V / 60 Hz   | 120V / 60 Hz   | 120V / 60 Hz  |
| <b>Color Options</b>         | Stainless   | Black Stainless <sup>2</sup>   | Black with Mirror Finish   | Stainless  | Stainless, Black Stainless <sup>2</sup>  | Black Stainless <sup>2</sup>   | Stainless, Black Stainless <sup>2</sup>   |
| <b>Dimensions (WxHxD)</b>    | 20 <sup>13</sup> / <sub>16</sub> " x 15 <sup>7</sup> / <sub>8</sub> " x 18 <sup>1</sup> / <sub>16</sub> " | 20 <sup>9</sup> / <sub>16</sub> " x 12 <sup>3</sup> / <sub>16</sub> " x 19 <sup>15</sup> / <sub>16</sub> " | 27 <sup>7</sup> / <sub>8</sub> " x 12 <sup>5</sup> / <sub>16</sub> " x 18 <sup>1</sup> / <sub>16</sub> " | 20 <sup>3</sup> / <sub>8</sub> " x 11 <sup>11</sup> / <sub>16</sub> " x 15 <sup>13</sup> / <sub>16</sub> " | 23 <sup>5</sup> / <sub>8</sub> " x 13 <sup>9</sup> / <sub>32</sub> " x 18 <sup>7</sup> / <sub>16</sub> " | 29 <sup>3</sup> / <sub>4</sub> " x 13 <sup>9</sup> / <sub>32</sub> " x 18 <sup>7</sup> / <sub>16</sub> " | 21 <sup>7</sup> / <sub>8</sub> " x 18 <sup>5</sup> / <sub>8</sub> " x 12 <sup>5</sup> / <sub>16</sub> " |

<sup>1</sup>Also available in fingerprint-resistant Matte Black Stainless (MS19M8020TG) with Trim Kit™ option (MA-TK8020TG).  
<sup>2</sup>Fingerprint-resistant finish





SAMSUNG

POWER Low Med High Boost  
LIGHT  
Auto Clean

# Ventilation

Download Spec Sheets and Line Drawings at [samsung.com/builder](https://samsung.com/builder)





## Bluetooth® Connectivity

Bluetooth® connects the range or cooktop to the hood, so the fan automatically starts when they do.

## Digital Touch Controls

All models feature seamlessly integrated controls that are as beautiful as they are easy to clean.



## Wi-Fi Enabled

Control the vent hood's power, speed and LED lights directly from your mobile device when connected with a compatible Samsung range/cooktop.

## Modern Design

Dishwasher-safe baffle filters help keep the air clean by drawing grease and odor through the hood.



# NK30K7000

## 30" Range Hood

### Available Colors



Fingerprint  
Resistant Black  
Stainless Steel  
NK30K7000WG/AZ



Stainless Steel  
NK30K7000WS/AZ

### Connected Hood<sup>1</sup>

Automatically sync the fans and the lights with the cooktop through Bluetooth®.

### Powerful 390 CFM<sup>2</sup> Ventilation

Circulates air to remove odors quickly.

### Baffle Filter

Dishwasher-safe metal filters help keep the air clean by drawing grease and odor through the hood.

### ADA Compliant

Designed for accessibility and controllability from your smartphone.

### Wi-Fi Monitoring<sup>1</sup>

Control the connected hood vent and LED lights remotely from your smartphone.

<sup>1</sup>When connected with a compatible Samsung range/cooktop  
<sup>2</sup>600 CFM capable



# NK36K7000

## 36" Range Hood

### Available Colors



Fingerprint  
Resistant Black  
Stainless Steel  
NK36K7000WG/AZ



Stainless Steel  
NK36K7000WS/AZ

### Connected Hood<sup>1</sup>

Automatically sync the fans and the lights with the cooktop through Bluetooth®.

### Powerful 390 CFM<sup>2</sup> Ventilation

Circulates air to remove odors quickly.

### Baffle Filter

Dishwasher-safe metal filters help keep the air clean by drawing grease and odor through the hood.

### ADA Compliant

Designed for accessibility and controllability from your smartphone.

### Wi-Fi Monitoring<sup>1</sup>

Control the connected hood vent and LED lights remotely from your smartphone.

<sup>1</sup>When connected with a compatible Samsung range/cooktop  
<sup>2</sup>600 CFM capable





# NK30N7000

30" Under Cabinet Range Hood

### Available Colors



Fingerprint  
Resistant Black  
Stainless Steel  
NK30N7000UG/AA



Stainless Steel  
NK30N7000US/AA



### Connected Hood<sup>1</sup>

Automatically sync the fans and the lights with the cooktop through Bluetooth®.

### Powerful 390 CFM<sup>2</sup> Ventilation

Circulates air to remove odors quickly.

### Baffle Filter

Dishwasher-safe metal filters help keep the air clean by drawing grease and odor through the hood.

### ADA Compliant

Designed for accessibility and controllability from your smartphone.

### Wi-Fi Monitoring<sup>1</sup>

Control the connected hood vent and LED lights remotely from your smartphone.

<sup>1</sup>When connected with a compatible Samsung range/cooktop  
<sup>2</sup>600 CFM capable

# NK36N7000

36" Under Cabinet Range Hood

### Available Colors



Fingerprint  
Resistant Black  
Stainless Steel  
NK36N7000UG/AA



Stainless Steel  
NK36N7000US/AA



### Connected Hood<sup>1</sup>

Automatically sync the fans and the lights with the cooktop through Bluetooth®.

### Powerful 390 CFM<sup>2</sup> Ventilation

Circulates air to remove odors quickly.

### Baffle Filter

Dishwasher-safe metal filters help keep the air clean by drawing grease and odor through the hood.

### ADA Compliant

Designed for accessibility and controllability from your smartphone.

### Wi-Fi Monitoring<sup>1</sup>

Control the connected hood vent and LED lights remotely from your smartphone.

<sup>1</sup>When connected with a compatible Samsung range/cooktop  
<sup>2</sup>600 CFM capable



Ventilation

# Ventilation





| Model                                   | 36" Range Hood<br>NK36K7000  | 30" Range Hood<br>NK30K7000  | 36" Range Hood<br>NK36N7000  | 30" Range Hood<br>NK30N7000  |
|---|--|--|--|--|
| Wi-Fi Monitoring <sup>1</sup>           | ✓  | ✓  | ✓  | ✓  |
| Bluetooth®<br>Connectivity <sup>2</sup> | ✓  | ✓  | ✓  | ✓  |
| # of Removable<br>Baffle Filters        | 3  | 2  | 3  | 2  |
| Controls                                | Digital Touch  | Digital Touch  | Digital Touch  | Digital Touch  |
| LED Lighting                            | ✓  | ✓  | ✓  | ✓  |
| Fan Speeds                              | 4 with Boost   | 4 with Boost   | 4 with Boost   | 4 with Boost   |
| CFM                                     | 390 CFM (600 CFM capable)  | 390 CFM (600 CFM capable)  | 390 CFM (600 CFM capable)  | 390 CFM (600 CFM capable)  |
| Venting                                 | External Venting & Recirculating Capable                                     | External Venting & Recirculating Capable                                     | External Venting & Recirculating Capable                                 | External Venting & Recirculating Capable                                 |
| Noise Level                             | 74 dBA   | 74 dBA   | 75 dBA   | 75 dBA   |
| Design                                  | Wall-Mounted Chimney Style<br>(Optional extension kit available)             | Wall-Mounted Chimney Style<br>(Optional extension kit available)             | Under Cabinet Style  | Under Cabinet Style  |
| Optional<br>Extension Kit               | NK-AE705PWS (Stainless),<br>NK-AE705PWG (Black Stainless <sup>3</sup> )      | NK-AE705PWS (Stainless),<br>NK-AE705PWG (Black Stainless <sup>3</sup> )      |  |  |
| Optional<br>Recirculating Kit           | NK-AF030FNB  | NK-AF030FNB  | NK-AF030FNB  | NK-AF030FNB  |
| Replacement<br>Charcoal Filter Kit      | NK-AR050FNB  | NK-AR050FNB  | NK-AR050FNB  | NK-AR050FNB  |
| ADA Compliant                           | ✓  | ✓  | ✓  | ✓  |
| Power Ratings                           | 120V / 60 Hz / 15 Amps   | 120V / 60 Hz / 15 Amps   | 120V / 60 Hz / 15 Amps   | 120V / 60 Hz / 15 Amps   |
| Color Options                           | Stainless, Black Stainless <sup>3</sup>                                      | Stainless, Black Stainless <sup>3</sup>                                      | Stainless, Black Stainless <sup>3</sup>                                  | Stainless, Black Stainless <sup>3</sup>                                  |
| Dimensions (WxHxD)                      | 36" x 25 <sup>7</sup> / <sub>16</sub> " x 19 <sup>11</sup> / <sub>16</sub> " | 30" x 25 <sup>7</sup> / <sub>16</sub> " x 19 <sup>11</sup> / <sub>16</sub> " | 36" x 9 <sup>3</sup> / <sub>4</sub> " x 19 <sup>3</sup> / <sub>4</sub> " | 30" x 9 <sup>3</sup> / <sub>4</sub> " x 19 <sup>3</sup> / <sub>4</sub> " |

<sup>1</sup>Only when connected through Bluetooth®

<sup>2</sup>Only compatible with select Samsung cooktops/ranges

<sup>3</sup>Fingerprint-resistant finish





POWER

Cycle  
Auto | Normal | Heavy | Delicate | Express 60'

Lower Rack  
Only | Zone Booster

Option  
Sanitize | Dry+  
\*Child Lock

Time Left  
68 40  
\*Hold 3 sec  
Delay Start

START  
\*Reset

# Dishwashers

Download Spec Sheets and Line Drawings at [samsung.com/builder](https://samsung.com/builder)





### WaterWall™

A powerful, streaming wall of water delivers remarkable cleaning results.

### StormWash™

A heavy-duty wash thoroughly cleans the messiest pots and pans without prewashing.



### AutoRelease™ Door

At the end of a cycle, the door automatically pops open to circulate air and accelerate drying time.

### Zone Booster™

Target different zones of your dishwasher with custom settings.



### Third Rack with FlexTray™

Removable rack that simplifies unloading silverware and oversized utensils.

### Hard Food Disposer

Advanced washing system allows for the disposal of solid food particles without the need to clean a filter.



# DW80M9960

Top Control Dishwasher with WaterWall™ Technology

## Available Colors



Fingerprint  
Resistant Black  
Stainless Steel

DW80M9960UG/AA



Stainless Steel  
DW80M9960US/AA

### WaterWall™ Linear Wash System

A powerful, streaming wall of water delivers remarkable cleaning results.

### AutoRelease™ Door

At the end of a cycle, the door automatically pops open to circulate air and accelerate drying time.

### Zone Booster™

Target different zones of your dishwasher with custom settings.

### Third Rack with FlexTray™

Removable rack simplifies unloading silverware and oversized utensils.

### Virtually Silent Wash Cycles - 38 dBA

With virtually silent wash cycles, this dishwasher is quietest in its class.\*

### Wi-Fi Connectivity

Remotely monitor and control the dishwasher from your smartphone.

\* Special insulation reduces noise to 38 dBA



# DW80M9550

Top Control Dishwasher with WaterWall™ Technology

## Available Colors



Fingerprint  
Resistant Black  
Stainless Steel

DW80M9550UG/AA



Stainless Steel  
DW80M9550US/AA

### WaterWall™ Linear Wash System

A powerful, streaming wall of water delivers remarkable cleaning results.

### AutoRelease™ Door

At the end of a cycle, the door automatically pops open to circulate air and accelerate drying time.

### Zone Booster™

Target different zones of your dishwasher with custom settings.

### Cutlery Caddy

Silverware basket can accommodate oversized utensils and can be removed for unloading.

### Virtually Silent Wash Cycles - 42 dBA

With virtually silent wash cycles, this dishwasher is quietest in its class.\*

\* Special insulation reduces noise to 42 dBA



## DW80K7050

Top Control Dishwasher with StormWash™

### Available Colors



Fingerprint Resistant Black Stainless Steel

DW80K7050UG/AA



Stainless Steel

DW80K7050US/AA

### StormWash™

A heavy-duty wash thoroughly cleans the messiest pots and pans without prewashing.

### AutoRelease™ Door

At the end of a cycle, the door automatically pops open to circulate air and accelerate drying time.

### Third Rack

Dedicated space for cutlery and utensils adds 30% more usable space to your dishwasher.

### Virtually Silent Wash Cycles - 44 dBA

A five-layer door and special insulation system significantly minimize noise during operation.

### Digital Leak Sensor

Identifies leaks as small as 1.01 oz. and shuts off the machine before water can escape.



## DW80K5050

Top Control Dishwasher with StormWash™

### Available Colors



Fingerprint Resistant Black Stainless Steel

DW80K5050UG/AA



Stainless Steel

DW80K5050US/AA



White

DW80K5050UW/AA

### StormWash™

A heavy-duty wash thoroughly cleans the messiest pots and pans without prewashing.

### AutoRelease™ Door

At the end of a cycle, the door automatically pops open to circulate air and accelerate drying time.

### Indicator Light

Shows you if the machine is running, even from across the room.

### Virtually Silent Wash Cycles - 48 dBA

A five-layer door and special insulation system significantly minimize noise during operation.

### Digital Leak Sensor

Identifies leaks as small as 1.01 oz. and shuts off the machine before water can escape.





## DW80N3030

Front Control Dishwasher with Stainless Steel Interior



### Third Rack

Dedicated space for cutlery and utensils adds 30% more usable space to your dishwasher.

### Digital Touch Controls

Easily select functions with a gentle touch.

### Height-Adjustable Upper Rack

Easily fits dishware of various shapes and sizes.

### Advanced Wash System

Heavy-duty wash gets the pots and pans clean.

### Digital Leak Sensor

Identifies leaks as small as 1.01 oz. and shuts off the machine before water can escape.



## DW80M2020

Front Control Dishwasher with Stainless Steel Interior



### Stainless Steel Door

The interior door is covered with stainless steel that's more durable and hygienic.\*

### Hard Food Disposer

Advanced washing system allows for the disposal of solid food particles without the need to clean a filter. Easily wash away heavy foods without pre-rinsing or scrubbing.

### Indicator Light

Shows you if the machine is running, even from across the room.

### Advanced Wash System

Heavy-duty wash gets the pots and pans clean.

### Digital Leak Sensor

Identifies leaks as small as 2.4 oz. and shuts off the machine before water can escape.



\* Than similar models with a plastic interior door





# Dishwashers





| Model                      | DW80M9960   | DW80M9550   | DW80K7050  | DW80K5050  | DW80N3030  | DW80M2020US  |
|----------------------------|---|---|--|--|--|--|
| <b>Cleaning System</b>     | WaterWall™  | WaterWall™  | Rotary   | Rotary   | Rotary   | Rotary   |
| <b>Wi-Fi</b>               | ✓   |   |  |  |  |  |
| <b>Quiet Sound: dBA</b>    | 38  | 42  | 44   | 48   | 51   | 55   |
| <b>AutoRelease™ Door</b>   | ✓   | ✓   | ✓  | ✓  |  |  |
| <b>Third Rack Option</b>   | Third Rack w/ Flex Tray™  | Easy Caddy  | Third Rack   |  | Third Rack   |  |
| <b>Targeted Cleaning</b>   | Zone Booster™   | Zone Booster™   | StormWash™   | StormWash™   |  |  |
| <b>Half Load Option</b>    | ✓   | ✓   | ✓  | ✓  |  |  |
| <b>Adjustable Racking</b>  | One Touch Trigger   | One Touch Trigger   | One Touch Trigger  | One Touch Trigger  | Two-step   | Two-step   |
| <b>Drying System</b>       | Condensation Drying w/<br>AutoRelease™ Door and Fan Assist                | Condensation Drying w/<br>AutoRelease™ Door and Fan Assist                | Condensation Drying w/<br>AutoRelease™ Door and Fan Assist   | Condensation Drying w/<br>AutoRelease™ Door and Fan Assist   | Condensation Drying w/ Fan Assist  | Heated Dry w/ Vent   |
| <b>Smart Leak Detector</b> | ✓   | ✓   | ✓  | ✓  | ✓  | ✓  |
| <b>Tub Material</b>        | Stainless Steel   | Stainless Steel   | Stainless Steel  | Stainless Steel  | Hybrid   | Hybrid   |
| <b>Rack Material</b>       | Nylon   | Nylon   | Nylon  | Nylon  | Nylon  | Nylon  |
| <b>Cycles/Options</b>      | 7/8   | 7/7   | 6/7  | 6/7  | 4/5  | 4/3  |
| <b>Door Handles</b>        | Pocket  | Pocket  | Standard Round   | Pocket   | Pocket   | Standard Round   |
| <b># of Place Settings</b> | 15  | 15  | 15   | 15   | 15   | 14   |
| <b>Silverware Basket</b>   | ✓   | ✓   | ✓  | ✓  | ✓  | ✓  |
| <b>Filtration System</b>   |   |   |  | Hard Food Disposer   |  |  |
| <b>ENERGY STAR®</b>        | ✓   | ✓   | ✓  | ✓  | ✓  | ✓  |
| <b>NSF</b>                 | ✓   | ✓   | ✓  | ✓  | ✓  | ✓  |
| <b>Power Ratings</b>       | 120V / 60 Hz / 15 Amps  | 120V / 60 Hz / 15 Amps  | 120V / 60 Hz / 15 Amps   | 120V / 60 Hz / 15 Amps   | 120V / 60 Hz / 15 Amps   | 120V / 60 Hz / 15 Amps   |
| <b>Color Options</b>       | Stainless, Black Stainless*   | Stainless, Black Stainless*   | Stainless, Black Stainless*  | Stainless, Black Stainless*, White   | Stainless, Black, White  | Stainless  |
| <b>Dimensions (WxHxD)</b>  | 23 <sup>7</sup> / <sub>8</sub> " x 33 <sup>7</sup> / <sub>8</sub> " x 25" | 23 <sup>7</sup> / <sub>8</sub> " x 33 <sup>7</sup> / <sub>8</sub> " x 25" | 23 <sup>7</sup> / <sub>8</sub> " x 33 <sup>7</sup> / <sub>8</sub> " to 35 <sup>7</sup> / <sub>8</sub> " x 24 <sup>3</sup> / <sub>4</sub> " | 23 <sup>7</sup> / <sub>8</sub> " x 33 <sup>7</sup> / <sub>8</sub> " to 35 <sup>7</sup> / <sub>8</sub> " x 24 <sup>3</sup> / <sub>4</sub> " | 23 <sup>3</sup> / <sub>4</sub> " x 33 <sup>3</sup> / <sub>4</sub> " to 35 <sup>1</sup> / <sub>8</sub> " x 24 <sup>5</sup> / <sub>8</sub> " | 23 <sup>3</sup> / <sub>4</sub> " x 33 <sup>3</sup> / <sub>4</sub> " x 24 <sup>5</sup> / <sub>8</sub> " |

\*Fingerprint-resistant finish





AKG

# Refrigerators

Download Spec Sheets and Line Drawings at [samsung.com/builder](https://samsung.com/builder)





## Family Hub™

Helps you manage your home and your life with Food Management, Family Connection and Entertainment capabilities — all controlled from a 21.5" connected touchscreen.

## Flexible Storage Options

Models with FlexZone™ have the versatility to switch between a refrigerator and a freezer. This feature is available on many 4-Door French Door and all Top Freezer models.



## Stunning Modern Design

French Door refrigerators are available in stylish 3- and 4-door designs with ultra high-capacity product options that save you trips to the store.

## Enhanced Storage Capacity

Side-By-Side refrigerators come with features like Food Showcase, which gives you easy access to the items you reach for most.



## Black Stainless Steel

Clean and contemporary, the black stainless steel finish brings an added level of sophistication to your kitchen.



## RF28N9780

28 cu. ft. 4-Door Flex™ with 21.5" Wi-Fi Enabled Touchscreen Family Hub™ Refrigerator

### Available Colors



Fingerprint Resistant Black Stainless Steel  
RF28N9780SG/AA



Fingerprint Resistant Stainless Steel  
RF28N9780SR/AA

### Food Management

Three built-in cameras take a picture of the inside of your fridge. Order groceries online from the touchscreen. Use your voice to add items to your shopping lists.

### Family Connection

Share multiple calendars, photos and notes.

### Entertainment

Stream music and video, or mirror your Samsung TV.

### Connected Kitchen

Control a number of devices and appliances from the Family Hub™, like turning on the lights, turning up your music or monitoring your baby's room.

### Bixby Voice Activation Features

Control your Family Hub™ from anywhere in your kitchen by using simple voice commands.

**Harman Kardon AKG Premium Quality Speakers**



## RF22N9781

22 cu. ft. Counter-Depth 4-Door Flex™ with 21.5" Wi-Fi Enabled Touchscreen Family Hub™ Refrigerator

### Available Colors



Fingerprint Resistant Black Stainless Steel  
RF22N9781SG/AA



Fingerprint Resistant Stainless Steel  
RF22N9781SR/AA

### Food Management

Three built-in cameras take a picture of the inside of your fridge. Order groceries online from the touchscreen. Use your voice to add items to your shopping lists.

### Family Connection

Share multiple calendars, photos and notes.

### Entertainment

Stream music and video, or mirror your Samsung TV.

### Connected Kitchen

Control a number of devices and appliances from the Family Hub™, like turning on the lights, turning up your music or monitoring your baby's room.

### Bixby Voice Activation Features

Control your Family Hub™ from anywhere in your kitchen by using simple voice commands.

**Harman Kardon AKG Premium Quality Speakers**



## RF28K9380

28 cu. ft. 4-Door Flex™ Food Showcase Refrigerator with FlexZone™



### Available Colors



Fingerprint Resistant Black Stainless Steel

RF28K9380SG/AA



Fingerprint Resistant Stainless Steel

RF28K9380SR/AA

### Food Showcase

An outer door provides quick and easy access to on-the-go items.

### FlexZone™

Versatile, bottom-right fridge compartment that converts freezer to fridge.

### Metal Cooling

Stainless steel paneling locks in cold and seals in freshness while maintaining consistent temperature throughout the refrigerator.

### Triple Cooling System

Provides precise temperature and humidity controls in all three zones. Your food stays fresher longer with three evaporators, an industry first.\*

### Ice Master

Produces up to 8.6 lbs. of ice per day and stores up to 4.2 lbs. of ice. This space-saving design leaves more room in the refrigerator.



\*Among consumer-grade freestanding refrigerators

## RF22K9381

22 cu. ft. Counter-Depth 4-Door Flex™ Food Showcase Refrigerator with FlexZone™



### Available Colors



Fingerprint Resistant Black Stainless Steel

RF22K9381SG/AA



Fingerprint Resistant Stainless Steel

RF22K9381SR/AA

### Food Showcase

An outer door provides quick and easy access to on-the-go items.

### FlexZone™

Versatile, bottom-right fridge compartment that converts freezer to fridge.

### Metal Cooling

Stainless steel paneling locks in cold and seals in freshness while maintaining consistent temperature throughout the refrigerator.

### Triple Cooling System

Provides precise temperature and humidity controls in all three zones. Your food stays fresher longer with three evaporators, an industry first.\*

### Ice Master

Produces up to 5 lbs. of ice per day and stores up to 2.9 lbs. of ice. This space-saving design leaves more room in the refrigerator.



\*Among consumer-grade freestanding refrigerators



## RF28K9070

28 cu. ft. 4-Door Flex™ Refrigerator with FlexZone™

### Available Colors



Fingerprint Resistant Black Stainless Steel  
RF28K9070SG/AA



Fingerprint Resistant Stainless Steel  
RF28K9070SR/AA

### FlexZone™

Versatile, bottom-right fridge compartment that converts freezer to fridge.

### Large Capacity

Our 4-Door Flex™ refrigerator has enough room to fit up to 28 bags of groceries.<sup>1</sup>

### Surface LED Lighting

Gently brightens virtually every corner of your refrigerator.

### Triple Cooling System

Provides precise temperature and humidity controls in all three zones. Your food stays fresher longer with three evaporators, an industry first.<sup>2</sup>

### Ice Master

Produces up to 8.8 lbs. of ice per day and stores up to 4.2 lbs. of ice. This space-saving design leaves more room in the refrigerator.



<sup>1</sup>Grocery comparison based on each cubic foot of usable space equaling one paper bag

<sup>2</sup>Among consumer-grade freestanding refrigerators

## RF23J9011

23 cu. ft. Counter-Depth 4-Door Flex™ Refrigerator with FlexZone™

### Available Colors



Fingerprint Resistant Black Stainless Steel  
RF23J9011SG/AA



Fingerprint Resistant Stainless Steel  
RF23J9011SR/AA

### Counter-Depth Design

Sleek, built-in design.

### FlexZone™

Versatile, bottom-right fridge compartment that converts freezer to fridge.

### Large Capacity

Our 4-Door Flex™ refrigerator has enough room to fit up to 23 bags of groceries.<sup>1</sup>

### Triple Cooling System

Provides precise temperature and humidity controls in all three zones. Your food stays fresher longer with three evaporators, an industry first.<sup>2</sup>

### Ice Master

Produces up to 5 lbs. of ice per day and stores up to 2.9 lbs. of ice. This space-saving design leaves more room in the refrigerator.



<sup>1</sup>Grocery comparison based on each cubic foot of usable space equaling one paper bag

<sup>2</sup>Among consumer-grade freestanding refrigerators





## RF23M8590

22 cu. ft. Counter-Depth 4-Door French Door with 21.5" Wi-Fi Enabled Touchscreen Family Hub™ Refrigerator

### Available Colors



Fingerprint Resistant Black Stainless Steel

RF23M8590SG/AA



Fingerprint Resistant Stainless Steel

RF23M8590SR/AA

### Food Management

Three built-in cameras take a picture of the inside of your fridge. Order groceries online from the touchscreen. Use your voice to add items to your shopping lists.

### Family Connection

Share multiple calendars, photos and notes.

### Entertainment

Stream music and video, or mirror your Samsung TV.

### Connected Kitchen

Control a number of devices and appliances from the Family Hub™, like turning on the lights, turning up your music or monitoring your baby's room.

### Bixby Voice Activation Features

Control your Family Hub™ from anywhere in your kitchen by using simple voice commands.

### Polygon Handles

Provide an easy grip and beautiful style.



## RF23M8570

22 cu. ft. Counter-Depth 4-Door French Door with 21.5" Wi-Fi Enabled Touchscreen Family Hub™ Refrigerator

### Available Colors



Fingerprint Resistant Black Stainless Steel

RF23M8570SG/AA



Fingerprint Resistant Stainless Steel

RF23M8570SR/AA

### Food Management

Three built-in cameras take a picture of the inside of your fridge. Order groceries online from the touchscreen. Use your voice to add items to your shopping lists.

### Family Connection

Share multiple calendars, photos and notes.

### Entertainment

Stream music and video, or mirror your Samsung TV.

### Connected Kitchen

Control a number of devices and appliances from the Family Hub™, like turning on the lights, turning up your music or monitoring your baby's room.

### Bixby Voice Activation Features

Control your Family Hub™ from anywhere in your kitchen by using simple voice commands.





## RF23M8090

23 cu. ft. Counter-Depth 4-Door French Door Refrigerator with FlexZone™

### Available Colors



Fingerprint Resistant Black Stainless Steel

RF23M8090SG/AA



Fingerprint Resistant Stainless Steel

RF23M8090SR/AA

### FlexZone™ Drawer

Versatile, mid-drawer fridge compartment with four temperature control settings and Smart Divider.

### Autofill Water Pitcher

The built-in Autofill Pitcher automatically refills, providing cold water anytime you need it and the option to infuse your favorite refreshing flavor.

### Built-In Look

Sleek, built-in design.

\*Compared to single-evaporator cooling systems



## RF23M8070

23 cu. ft. Counter-Depth 4-Door French Door Refrigerator with FlexZone™

### Available Colors



Fingerprint Resistant Black Stainless Steel

RF23M8070SG/AA



Fingerprint Resistant Stainless Steel

RF23M8070SR/AA

### FlexZone™ Drawer

Versatile, mid-drawer fridge compartment with four temperature control settings and Smart Divider.

### Autofill Water Pitcher

The built-in Autofill Pitcher automatically refills, providing cold water anytime you need it and the option to infuse your favorite refreshing flavor.

### Built-In Look

Sleek, built-in design.

\*Compared to single-evaporator cooling systems



# RF30KMEDB

30 cu. ft. 4-Door French Door Refrigerator

### Available Colors



Fingerprint Resistant Black Stainless Steel  
RF30KMEDBSG/AA



Stainless Steel  
RF30KMEDBSR/AA

### FlexZone™ Drawer

Optimized for family organization. It includes an adjustable Smart Divider, easy access for kids and four temperature control settings from Chill to Soft Freeze.

### Extra-Large Capacity

Our 4-Door French Door refrigerator has enough room to fit up to 30 bags of groceries.<sup>1</sup>

### Twin Cooling Plus™

Maintains high levels of refrigerator humidity to keep perishable fruits and vegetables fresher longer. Dry freezer conditions mean less freezer burn for better-tasting frozen foods.<sup>2</sup>

### Ice Master

Produces up to 10 lbs. of ice per day and stores up to 4.2 lbs. of ice. This space-saving design leaves more room in the refrigerator.

<sup>1</sup>Grocery comparison based on each cubic foot of usable space equaling one paper bag

<sup>2</sup>Among consumer-grade freestanding refrigerators



# RF24FSEDBSR

24 cu. ft. 4-Door French Door Counter-Depth Refrigerator

### Available Color



Stainless Steel  
RF24FSEDBSR/AA

### FlexZone™ Drawer

Optimized for family organization. It includes an adjustable Smart Divider, easy access for kids and four temperature control settings from Chill to Soft Freeze.

### Counter-Depth Design

Stylish counter-depth design allows for more workable space in the kitchen.

### Twin Cooling Plus™

Maintains high levels of refrigerator humidity to keep perishable fruits and vegetables fresher longer. Dry freezer conditions mean less freezer burn for better-tasting frozen foods.\*

### Ice Master

Produces up to 5.2 lbs. of ice per day and stores up to 2.7 lbs. of ice. This space-saving design leaves more room in the refrigerator.

\*Compared to single-evaporator cooling systems



## RF28NHEDB

28 cu. ft. 4-Door French Door with 21.5" Wi-Fi Enabled Touchscreen Family Hub™ Refrigerator

### Available Colors



Fingerprint Resistant Black Stainless Steel  
RF28NHEDBSG/AA



Stainless Steel  
RF28NHEDBSR/AA

### Food Management

Three built-in cameras take a picture of the inside of your fridge. Order groceries online from the touchscreen. Use your voice to add items to your shopping lists.

### Family Connection

Share multiple calendars, photos and notes.

### Entertainment

Stream music and video, or mirror your Samsung TV.

### Connected Kitchen

Control a number of devices and appliances from the Family Hub™, like turning on the lights, turning up your music or monitoring your baby's room.

### Bixby Voice Activation Features

Control your Family Hub™ from anywhere in your kitchen by using simple voice commands.



## RF22NPEDB

22 cu. ft. Counter-Depth 4-Door French Door with 21.5" Wi-Fi Enabled Touchscreen Family Hub™ Refrigerator

### Available Colors



Fingerprint Resistant Black Stainless Steel  
RF22NPEDBSG/AA



Stainless Steel  
RF22NPEDBSR/AA

### Food Management

Three built-in cameras take a picture of the inside of your fridge. Order groceries online from the touchscreen. Use your voice to add items to your shopping lists.

### Family Connection

Share multiple calendars, photos and notes.

### Entertainment

Stream music and video, or mirror your Samsung TV.

### Connected Kitchen

Control a number of devices and appliances from the Family Hub™, like turning on the lights, turning up your music or monitoring your baby's room.

### Bixby Voice Activation Features

Control your Family Hub™ from anywhere in your kitchen by using simple voice commands.





## RF28JBEDB

28 cu. ft. 4-Door French Door Food Showcase Refrigerator

### Available Colors



Fingerprint Resistant Black Stainless Steel  
RF28JBEDBSG/AA



Stainless Steel  
RF28JBEDBSR/AA

### Food Showcase

An outer door provides quick and easy access to on-the-go items.

### FlexZone™ Drawer

Cools food faster<sup>1</sup> and provides an optimal place to store dairy, beverages and snacks. Adjustable Smart Divider is optimized for smart organization and easy access, and is kid-friendly.

### Metal Cooling

Stainless steel paneling locks in cold and seals in freshness.

<sup>1</sup>Compared to Samsung refrigerator with plastic cooling plate

<sup>2</sup>Compared to single-evaporator cooling systems

<sup>3</sup>Grocery comparison based on each cubic foot of usable space equaling one paper bag



## RF22KREDB

22 cu. ft. Counter-Depth 4-Door French Door Food Showcase Refrigerator

### Available Colors



Fingerprint Resistant Black Stainless Steel  
RF22KREDBSG/AA



Stainless Steel  
RF22KREDBSR/AA

### Food Showcase

An outer door provides quick and easy access to on-the-go items.

### FlexZone™ Drawer

Cools food faster<sup>1</sup> and provides an optimal place to store dairy, beverages and snacks. Adjustable Smart Divider is optimized for smart organization and easy access, and is kid-friendly.

### Metal Cooling

Stainless steel paneling locks in cold and seals in freshness.

### Counter-Depth Design

Sleek, built-in design.

### Large Capacity

Our 4-Door French Door refrigerator has enough room to fit up to 22 bags of groceries.<sup>2</sup>

<sup>1</sup>Compared to Samsung refrigerator with plastic cooling plate

<sup>2</sup>Grocery comparison based on each cubic foot of usable space equaling one paper bag





## RF28HMEDB

28 cu. ft. 4-Door French Door with Counter-Height FlexZone™ Drawer Refrigerator



**FlexZone™ Drawer**  
The counter-height FlexZone™ drawer is optimized for family organization. It includes an adjustable Smart Divider, easy access for kids and four temperature control settings from Chill to Soft Freeze.

**Large Capacity**  
Our 4-Door French Door refrigerator has enough room to fit up to 28 bags of groceries.<sup>1</sup>

**Twin Cooling Plus™**  
Maintains high levels of refrigerator humidity to keep perishable fruits and vegetables fresher longer. Dry freezer conditions mean less freezer burn for better-tasting frozen foods.<sup>2</sup>

**Ice Master**  
Produces up to 10 lbs. of ice per day and stores up to 4.2 lbs. of ice. This space-saving design leaves more room in the refrigerator.

<sup>1</sup>Grocery comparison based on each cubic foot of usable space equaling one paper bag  
<sup>2</sup>Compared to single-evaporator cooling systems



## RF25HMEDB

25 cu. ft. 4-Door French Door with Counter-Height FlexZone™ Drawer Refrigerator



**FlexZone™ Drawer**  
The counter-height FlexZone™ drawer is optimized for family organization. It includes an adjustable Smart Divider, easy access for kids and four temperature control settings from Chill to Soft Freeze.

**Large Capacity**  
Our 4-Door French Door refrigerator has enough room to fit up to 25 bags of groceries.<sup>1</sup>

**Twin Cooling Plus™**  
Maintains high levels of refrigerator humidity to keep perishable fruits and vegetables fresher longer. Dry freezer conditions mean less freezer burn for better-tasting frozen foods.<sup>2</sup>

**Ice Master**  
Produces up to 10 lbs. of ice per day and stores up to 4.2 lbs. of ice. This space-saving design leaves more room in the refrigerator.

<sup>1</sup>Grocery comparison based on each cubic foot of usable space equaling one paper bag  
<sup>2</sup>Compared to single-evaporator cooling systems



# RF28HDEDB/P

28 cu. ft. French Door  
Food Showcase Refrigerator



### Available Colors



Fingerprint  
Resistant Black  
Stainless Steel  
RF28HDEDBSG/AA



Stainless Steel  
RF28HDEDBSR/AA RF28HDEDPWW/AA



White



### Food Showcase

An outer door provides quick and easy access to on-the-go items.

### CoolSelect Pantry™

Provides optimal temperature control for your food storage needs with Deli, Fresh and Chilled options.

### Metal Cooling

Stainless steel paneling locks in cold and seals in freshness.

### Twin Cooling Plus™

Maintains high levels of refrigerator humidity to keep perishable fruits and vegetables fresher longer. Dry freezer conditions mean less freezer burn for better-tasting frozen foods.<sup>1</sup>

### Large Capacity

Our 3-Door French Door refrigerator has enough room to fit up to 28 bags of groceries.<sup>2</sup>

<sup>1</sup>Compared to single-evaporator cooling systems

<sup>2</sup>Grocery comparison based on each cubic foot of usable space equaling one paper bag

# RF23HTEDB

23 cu. ft. Counter-Depth French Door  
Food Showcase Refrigerator



### Available Color



Stainless Steel  
RF23HTEDBSR/AA



### Food Showcase

An outer door provides quick and easy access to on-the-go items.

### Counter-Depth Design

Stylish counter-depth design allows for more workable space in the kitchen.

### Metal Cooling

Stainless steel paneling locks in cold and seals in freshness.

### Twin Cooling Plus™

Maintains high levels of refrigerator humidity to keep perishable fruits and vegetables fresher longer. Dry freezer conditions mean less freezer burn for better-tasting frozen foods.<sup>1</sup>

### Large Capacity

Our 3-Door French Door refrigerator has enough room to fit up to 23 bags of groceries.<sup>2</sup>

<sup>1</sup>Compared to single-evaporator cooling systems

<sup>2</sup>Grocery comparison based on each cubic foot of usable space equaling one paper bag



## RF28HFEDB

28 cu. ft. French Door Refrigerator with CoolSelect Pantry™

### Available Colors



Fingerprint Resistant Black Stainless Steel  
RF28HFEDBSG/AA



Stainless Steel  
RF28HFEDBSR/AA



White  
RF28HFEDBWW/AA

### CoolSelect Pantry™

Provides optimal temperature control for your food storage needs with Deli, Fresh and Chilled options.

### High-Efficiency LED Lighting

Brighter, cooler and more energy-efficient.

### Large Capacity

Our 3-door French Door refrigerator has enough room to fit up to 28 bags of groceries.<sup>1</sup>

### Twin Cooling Plus™

Maintains high levels of refrigerator humidity to keep perishable fruits and vegetables fresher longer. Dry freezer conditions mean less freezer burn for better-tasting frozen foods.<sup>2</sup>

### Ice Master

Produces up to 10 lbs. of ice per day and stores up to 4.2 lbs. of ice. This space-saving design leaves more room in the refrigerator.

<sup>1</sup>Grocery comparison based on each cubic foot of usable space equaling one paper bag

<sup>2</sup>Compared to single-evaporator cooling systems



## RF26J7500

33"-Wide, 26 cu. ft. French Door Refrigerator with CoolSelect Pantry™

### Available Colors



Stainless Steel  
RF26J7500SR/AA



White  
RF26J7500WW/AA

### CoolSelect Pantry™

Provides optimal temperature control for your food storage needs with Deli, Fresh and Chilled options.

### High-Efficiency LED Lighting

Brighter, cooler and more energy-efficient.

### Large Capacity

Our 3-door French Door refrigerator has enough room to fit up to 26 bags of groceries.<sup>1</sup>

### Twin Cooling Plus™

Maintains high levels of refrigerator humidity to keep perishable fruits and vegetables fresher longer. Dry freezer conditions mean less freezer burn for better-tasting frozen foods.<sup>2</sup>

### Ice Master

Produces up to 9.9 lbs. of ice per day and stores up to 4.2 lbs. of ice. This space-saving design leaves more room in the refrigerator.

<sup>1</sup>Grocery comparison based on each cubic foot of usable space equaling one paper bag

<sup>2</sup>Compared to single-evaporator cooling systems





# RF263BEAE

25 cu. ft. French Door Refrigerator with External Water & Ice Dispenser

### Available Colors

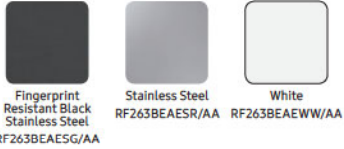

### CoolSelect Pantry™

Provides optimal temperature control for your food storage needs with Deli, Fresh and Chilled options.

### Fresh Filtered Water

Get great-tasting filtered water directly from your refrigerator. Spend less time and money buying bottled water.

### Auto Pull-Out Freezer Drawer

Automatically slides out for easy access, organization and storage.

### Twin Cooling Plus™

Maintains high levels of refrigerator humidity to keep perishable fruits and vegetables fresher longer. Dry freezer conditions mean less freezer burn for better-tasting frozen foods.\*

### Ice Master

Produces up to 10 lb. of ice per day and stores up to 4.2 lb. of ice. This space-saving design leaves more room in the refrigerator.

\*Compared to single-evaporator cooling systems



# RF23HCEDB

23 cu. ft. Counter-Depth French Door Refrigerator

### Available Colors

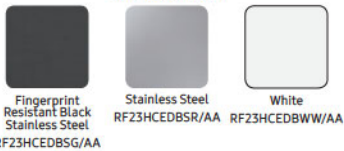

### CoolSelect Pantry™

Provides optimal temperature control for your food storage needs with Deli, Fresh and Chilled options.

### High-Efficiency LED Lighting

Brighter, cooler and more energy-efficient.

### Counter-Depth Design

Stylish counter-depth design allows for more workable space in the kitchen.

### Twin Cooling Plus™

Maintains high levels of refrigerator humidity to keep perishable fruits and vegetables fresher longer. Dry freezer conditions mean less freezer burn for better-tasting frozen foods.\*

### Ice Master

Produces up to 5.2 lbs. of ice per day and stores up to 2.7 lbs. of ice. This space-saving design leaves more room in the refrigerator.

\*Compared to single-evaporator cooling systems





## RF265BEAE

24 cu. ft. French Door Refrigerator with Family Hub™

### Available Colors



Fingerprint Resistant Black Stainless Steel  
RF265BEAESG/AA



Stainless Steel  
RF265BEAESR/AA

### Food Management

Three built-in cameras take a picture of the inside of your fridge. Order groceries online from the touchscreen.

### Family Connection

Share multiple calendars, photos and notes.

### Entertainment

Stream music and video, or mirror your Samsung TV.

### Connected Kitchen

Control a number of devices and appliances from the Family Hub™, like turning on the lights, turning up your music or monitoring your baby's room.

### Bixby Voice Activation Features

Control your Family Hub™ from anywhere in your kitchen by using simple voice commands.



## RF261BEAE

26 cu. ft. French Door Refrigerator with Internal Filtered Water

### Available Colors



Fingerprint Resistant Black Stainless Steel  
RF261BEAESG/AA



Stainless Steel  
RF261BEAESR/AA



White  
RF261BEAEWW/AA

### CoolSelect Pantry™

Provides optimal temperature control for your food storage needs with Deli, Fresh and Chilled options.

### High-Efficiency LED Lighting

Brighter, cooler and more energy-efficient.

### Auto Pull-Out Freezer Drawer

Great place to store your commonly used frozen foods like ice cream. Automatically slides out for easy access, organization and storage.

### Twin Cooling Plus™

Maintains high levels of refrigerator humidity to keep perishable fruits and vegetables fresher longer. Dry freezer conditions mean less freezer burn for better-tasting frozen foods.<sup>1</sup>

### Sleek and Roomy

Beautiful, sleek design fits any kitchen décor and has enough room to fit up to 26 bags of groceries.<sup>2</sup>



<sup>1</sup>Compared to single-evaporator cooling systems

<sup>2</sup>Grocery comparison based on each cubic foot of usable space equaling one paper bag



# RF260BEAE

26 cu. ft. French Door Refrigerator with Filtered Ice Maker



### Available Colors



### CoolSelect Pantry™

Provides optimal temperature control for your food storage needs with Deli, Fresh and Chilled options.

### High-Efficiency LED Lighting

Brighter, cooler and more energy-efficient.

### Auto Pull-Out Freezer Drawer

Automatically slides out for easy access, organization and storage.

### Twin Cooling Plus™

Maintains high levels of refrigerator humidity to keep perishable fruits and vegetables fresher longer. Dry freezer conditions mean less freezer burn for better-tasting frozen foods.<sup>1</sup>

### Sleek and Roomy

Beautiful, sleek design fits any kitchen décor and has enough room to fit up to 26 bags of groceries.<sup>2</sup>

<sup>1</sup>Compared to single-evaporator cooling systems

<sup>2</sup>Grocery comparison based on each cubic foot of usable space equaling one paper bag



# RF220NCTA

30"-Wide, 22 cu. ft. Capacity French Door Refrigerator

### Available Colors

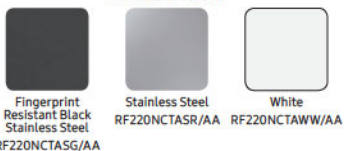

### Sleek and Roomy

Beautiful, sleek design fits any kitchen décor and has enough room to fit up to 22 bags of groceries.<sup>1</sup>

### High-Efficiency LED Lighting

Brighter, cooler and more energy-efficient.

### Wide Open Pantry

Store long, flat and wide food items.

### Filtered Ice Maker in the Freezer

The automatic filtered<sup>2</sup> ice maker in the freezer offers convenient access to ice. It provides filtered ice cubes and helps ensure you have ice on hand at all times.

<sup>1</sup>Grocery comparison based on each cubic foot of usable space equaling one paper bag

<sup>2</sup>Filter not included



## RF20HFENB

33"-Wide, 20 cu. ft. Capacity French Door Refrigerator

### Available Colors



Fingerprint Resistant Black Stainless Steel  
RF20HFENBSG/US



Stainless Steel  
RF20HFENBSR/US



White  
RF20HFENBWW/US

### 20 cu. ft. Capacity

Our 3-Door French Door refrigerator stores up to 20 bags of groceries<sup>1</sup> in a sleek 33"-wide model.

### Automatic Filtered Ice Maker

Filtered ice cubes in the freezer to ensure you have ice on hand at all times.

### LED Lighting

Beautifully brightens virtually every corner of your refrigerator so you're able to quickly spot what you want. It emits less heat and is more energy-efficient than conventional lighting.

### Twin Cooling Plus™

Maintains high levels of refrigerator humidity to keep perishable fruits and vegetables fresher longer.<sup>2</sup> Dry freezer conditions mean less freezer burn for better-tasting frozen foods.

### Surround Air Flow

Maintains optimal temperatures and ensures air circulates for even cooling throughout the refrigerator.

<sup>1</sup>Grocery comparison based on each cubic foot of usable space equaling one paper bag  
<sup>2</sup>Twin Cooling® humidity levels up to 5x higher than single cooling systems



## RF18HFENB

33"-Wide, 18 cu. ft. Counter-Depth French Door Refrigerator

### Available Colors



Fingerprint Resistant Black Stainless Steel  
RF18HFENBSG/US



Stainless Steel  
RF18HFENBSR/US



White  
RF18HFENBWW/US

### 18 cu. ft. Capacity

Our 3-Door French Door refrigerator, stores up to 18 bags of groceries<sup>1</sup> in a sleek 33"-wide model.

### Counter-Depth Design

Get more workspace while enhancing your kitchen's look with our counter-depth refrigerator design.

### LED Lighting

Beautifully brightens virtually every corner of your refrigerator so you're able to quickly spot what you want. It emits less heat and is more energy-efficient than conventional lighting.

### Twin Cooling Plus®

Maintains high levels of refrigerator humidity to keep perishable fruits and vegetables fresher longer.<sup>2</sup> Dry freezer conditions mean less freezer burn for better-tasting frozen foods.

### Surround Air Flow

Maintains optimal temperatures and ensures air circulates for even cooling throughout the refrigerator.

<sup>1</sup>Grocery comparison based on each cubic foot of usable space equaling one paper bag  
<sup>2</sup>Twin Cooling® humidity levels up to 5x higher than single cooling systems





## RH22H9010

22 cu. ft. Counter-Depth Side-By-Side Food Showcase Refrigerator with Metal Cooling



### Available Colors



Fingerprint Resistant Black Stainless Steel  
RH22H90105G/AA



Fingerprint Resistant Stainless Steel  
RH22H90105R/AA

### Food Showcase

An outer door provides quick and easy access to on-the-go items.

### Counter-Depth

The stylish counter-depth design allows for more workable space in the kitchen and has enough room to fit up to 22 bags of groceries.\*

### Metal Cooling

Stainless steel paneling locks in cold and seals in freshness.

### High-Efficiency LED Lighting

Brighter, cooler and more energy-efficient.

### Automatic In-Door Ice Maker

Maximizes freezer space, leaving more room for frozen foods and offers convenient access to ice, right inside the door. It can produce up to 4.4 lbs. of ice per day and stores up to 5.5 lbs. of ice.

\*Grocery comparison based on each cubic foot of usable space equaling one paper bag



## RS22HDHPN

22 cu. ft. Counter-Depth Side-By-Side Refrigerator



### Available Colors



Stainless Steel  
RS22HDHPNSR/AA



White  
RS22HDHPNWW/AA

### Large Capacity

Store up to 22 bags of groceries<sup>1</sup> in a sleek 36"-wide model.

### Counter-Depth

Get more workspace while enhancing your kitchen's look with our counter-depth refrigerator design.

### LED Tower Lighting

Gently brightens every corner of your refrigerator while reducing heat and energy output. Its space-saving design leaves more room for groceries.

### Twin Cooling Plus™

Maintains high levels of refrigerator humidity to keep perishable fruits and vegetables fresher longer. Dry freezer conditions mean less freezer burn for better-tasting frozen foods.<sup>2</sup>

### Automatic In-Door Ice Maker

Maximizes freezer space, leaving more room for frozen foods and offers convenient access to ice, right inside the door.

<sup>1</sup>Grocery comparison based on each cubic foot of usable space equaling one paper bag

<sup>2</sup>Compared to single-evaporator cooling systems





## RH25H5611

25 cu. ft. Side-By-Side Food Showcase Refrigerator with Metal Cooling

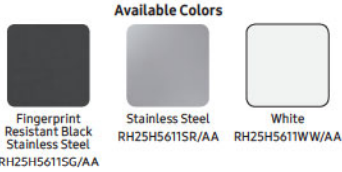

### Food Showcase

An outer door provides quick and easy access to on-the-go items.

### LED Tower Lighting

Gently brightens every corner of your refrigerator while reducing heat and energy output. Its space-saving design leaves more room for groceries.

### Metal Cooling

Stainless steel paneling locks in cold and seals in freshness.

### Twin Cooling Plus™

Maintains high levels of refrigerator humidity to keep perishable fruits and vegetables fresher longer.<sup>1</sup> Dry freezer conditions mean less freezer burn for better-tasting frozen foods.

### Large Capacity

Our Side-By-Side Food Showcase refrigerator has enough room to fit up to 25 bags of groceries.<sup>2</sup>



<sup>1</sup>Twin Cooling® humidity levels up to 5x higher than single cooling systems

<sup>2</sup>Grocery comparison based on each cubic foot of usable space equaling one paper bag

## RS25H5111

25 cu. ft. Side-By-Side Refrigerator with In-Door Ice Maker



### Large Capacity

Stores up to 25 bags of groceries<sup>1</sup> in a sleek 36"-wide model.

### Digital LED Display

Conveniently located above the water and ice dispenser on the refrigerator door.

### LED Tower Lighting

Gently brightens every corner of your refrigerator while reducing heat and energy output. Its space-saving design leaves more room for groceries.

### Twin Cooling Plus™

Maintains high levels of refrigerator humidity to keep perishable fruits and vegetables fresher longer. Dry freezer conditions mean less freezer burn for better-tasting frozen foods.<sup>2</sup>

### Automatic In-Door Ice Maker

Maximizes freezer space, leaving more room for frozen foods and offers convenient access to ice, right inside the door.



<sup>1</sup>Grocery comparison based on each cubic foot of usable space equaling one paper bag

<sup>2</sup>Compared to single-evaporator cooling systems



# RS25J500D

25 cu. ft. Side-By-Side Refrigerator with LED Lighting

## Available Colors



Fingerprint Resistant Black Stainless Steel  
RS25J500DSG/AA



Stainless Steel  
RS25J500DSR/AA



White  
RS25J500DWW/AA

### Large Capacity

Stores up to 25 bags of groceries\* in a sleek 36"-wide model.

### Two Humidity-Controlled Crisper Drawers

Keep your produce crisp and fresh with ideal storage space for all your fruits and vegetables.

### LED Lighting

Beautifully brightens virtually every corner of your refrigerator so you're able to quickly spot what you want. It also emits less heat and is more energy-efficient than conventional lighting.

### Digital LED Display

Conveniently located above the water and ice dispenser on the refrigerator door.

### External Water and Ice Dispenser

Get great-tasting filtered water directly from your refrigerator. Spend less time and money buying bottled water.



\*Grocery comparison based on each cubic foot of usable space equaling one paper bag



## RT21M6215

21 cu. ft. Top-Freezer Refrigerator with FlexZone™



### FlexZone™

Versatile fridge compartment that converts freezer to fridge.

### Slide & Reach Pantry

Easily access all your favorite foods.

### 2016 ENERGY STAR® Certified

Meets the strict 2016 energy efficiency specifications and standards.

### Twin Cooling Plus™

Maintains high levels of refrigerator humidity to keep perishable fruits and vegetables fresher longer. Dry freezer conditions mean less freezer burn for better-tasting frozen foods.\*

### Automatic Ice Maker

Produces up to 3.7 lbs. of ice per day.

\*Compared to single-evaporator cooling systems



## RT18M6215

18 cu. ft. Top-Freezer Refrigerator with FlexZone™



### FlexZone™

Versatile fridge compartment that converts freezer to fridge.

### Slide & Reach Pantry

Easily access all your favorite foods.

### 2016 ENERGY STAR® Certified

Meets the strict 2016 energy efficiency specifications and standards.

### Twin Cooling Plus™

Maintains high levels of refrigerator humidity to keep perishable fruits and vegetables fresher longer. Dry freezer conditions mean less freezer burn for better-tasting frozen foods.\*

### Automatic Ice Maker

Produces up to 3.7 lbs. of ice per day.

\*Compared to single-evaporator cooling systems



# RT21M6213

21 cu. ft. Top-Freezer Refrigerator with FlexZone™

### Available Colors



Fingerprint Resistant Black Stainless Steel  
RT21M6213SG/AA



Fingerprint Resistant Stainless Steel  
RT21M6213SR/AA



White  
RT21M6213WW/AA

### FlexZone™

Versatile fridge compartment that converts freezer to fridge.

### Slide & Reach Pantry

Easily access all your favorite foods.

### 2016 ENERGY STAR® Certified

Meets the strict 2016 energy efficiency specifications and standards.

### Twin Cooling Plus™

Maintains high levels of refrigerator humidity to keep perishable fruits and vegetables fresher longer. Dry freezer conditions mean less freezer burn for better-tasting frozen foods.\*

\*Compared to single-evaporator cooling systems



# RT18M6213

18 cu. ft. Top-Freezer Refrigerator with FlexZone™

### Available Colors



Fingerprint Resistant Black Stainless Steel  
RT18M6213SG/AA



Fingerprint Resistant Stainless Steel  
RT18M6213SR/AA



White  
RT18M6213WW/AA

### FlexZone™

Versatile fridge compartment that converts freezer to fridge.

### Slide & Reach Pantry

Easily access all your favorite foods.

### 2016 ENERGY STAR® Certified

Meets the strict 2016 energy efficiency specifications and standards.

### Twin Cooling Plus™

Maintains high levels of refrigerator humidity to keep perishable fruits and vegetables fresher longer. Dry freezer conditions mean less freezer burn for better-tasting frozen foods.\*

\*Compared to single-evaporator cooling systems





# Refrigerators

## 4-Door Flex





| Model                               | RF28N9780   | RF22N9781  | RF28K9380  | RF22K9381  | RF28K9070  | RF23J9011  |
|-------------------------------------|---|--|--|--|--|--|
| <b>Capacity</b>                     | Total: 28 cu. ft.<br>Refrigerator: 16.4 cu. ft.<br>Freezer: 11.5 cu. ft.                                | Total: 22 cu. ft.<br>Refrigerator: 13.2 cu. ft.<br>Freezer: 8.8 cu. ft.                                | Total: 28 cu. ft.<br>Refrigerator: 16.5 cu. ft.<br>Freezer: 11.5 cu. ft.                               | Total: 22 cu. ft.<br>Refrigerator: 13.3 cu. ft.<br>Freezer: 8.8 cu. ft.                                | Total: 28 cu. ft.<br>Refrigerator: 16.6 cu. ft.<br>Freezer: 11.5 cu. ft.                               | Total: 23 cu. ft.<br>Refrigerator: 13.6 cu. ft.<br>Freezer: 8.86 cu. ft.                               |
| <b>Family Hub™</b>                  | ✓ (3.0)   | ✓ (3.0)  |  |  |  |  |
| <b>Food Showcase</b>                |   |  | ✓  | ✓  |  |  |
| <b>Counter Depth</b>                |   | ✓  |  | ✓  |  | ✓  |
| <b>Dispenser</b>                    | Ice & Water   | Ice & Water  | Ice & Water  | Ice & Water  | Ice & Water  | Ice & Water  |
| <b>Cooling System</b>               | Triple Cooling  | Triple Cooling   | Triple Cooling   | Triple Cooling   | Triple Cooling   | Triple Cooling   |
| <b>Metal Cooling</b>                | ✓   | ✓  | ✓  | ✓  |  |  |
| <b>Ice Production &amp; Storage</b> | 8.8 lbs/day;<br>4.2 lbs   | 5.1 lbs/day;<br>2.9 lbs  | 8.6 lbs/day;<br>4.2 lbs  | 5 lbs/day;<br>2.9 lbs  | 8.8 lbs/day;<br>4.2 lbs  | 5 lbs/day;<br>2.9 lbs  |
| <b>LED Lighting</b>                 | HE LED  | HE LED   | Surface LED  | HE LED   | Surface LED  | HE LED   |
| <b>FlexZone™</b>                    | ✓   | ✓  | ✓  | ✓  | ✓  | ✓  |
| <b>AKG Speaker</b>                  | ✓   | ✓  |  |  |  |  |
| <b>Water Filter</b>                 | HAF-CIN<br>DA29-00020B  | HAF-CIN<br>DA29-00020B   | HAF-CIN<br>DA29-00020B   | HAF-CIN<br>DA29-00020B   | HAF-CIN<br>DA29-00020B   | HAF-CIN<br>DA29-00020B   |
| <b>Door Handles</b>                 | Recessed  | Recessed   | Recessed   | Recessed   | Recessed   | Recessed   |
| <b>ENERGY STAR®</b>                 | ✓   | ✓  | ✓  | ✓  | ✓  | ✓  |
| <b>Power Ratings</b>                | 115V / 60 Hz / 5.3 Amps   | 115V / 60 Hz / 5.3 Amps  | 115V / 60 Hz / 5.3 Amps  | 115V / 60 Hz / 5.3 Amps  | 115V / 60 Hz / 5.3 Amps  | 115V / 60 Hz / 5.3 Amps  |
| <b>Color Options</b>                | Stainless*, Black Stainless*  | Stainless*, Black Stainless*   | Stainless*, Black Stainless*   | Stainless*, Black Stainless*   | Stainless*, Black Stainless*   | Stainless*, Black Stainless*   |
| <b>Dimensions (WxHxD)</b>           | 35 <sup>3</sup> / <sub>4</sub> " x 71 <sup>7</sup> / <sub>8</sub> " x 34 <sup>5</sup> / <sub>16</sub> " | 35 <sup>3</sup> / <sub>4</sub> " x 71 <sup>7</sup> / <sub>8</sub> " x 28 <sup>7</sup> / <sub>8</sub> " | 35 <sup>3</sup> / <sub>4</sub> " x 71 <sup>7</sup> / <sub>8</sub> " x 34 <sup>1</sup> / <sub>4</sub> " | 35 <sup>3</sup> / <sub>4</sub> " x 71 <sup>7</sup> / <sub>8</sub> " x 28 <sup>7</sup> / <sub>8</sub> " | 35 <sup>3</sup> / <sub>4</sub> " x 71 <sup>7</sup> / <sub>8</sub> " x 34 <sup>1</sup> / <sub>4</sub> " | 35 <sup>3</sup> / <sub>4</sub> " x 71 <sup>7</sup> / <sub>8</sub> " x 28 <sup>7</sup> / <sub>8</sub> " |

\*Fingerprint-resistant finish



# Refrigerators

## 4-Door French Door





| Model                               | RF23M8590   | RF23M8570   | RF23M8090   | RF23M8070   | RF30KMEDB   | RF28NHEDB   | RF22NPEDB   | RF28JBEDB   | RF22KREDB   | RF28HMEDB   | RF25HMEDB   | RF24FSEDBSR   |   |
|-------------------------------------|---|---|---|---|---|---|---|---|---|---|---|---|---|
| <b>Capacity</b>                     | Total: 22 cu. ft.<br>Refrigerator:<br>12.5 cu. ft.<br>Freezer:<br>6.6 cu. ft. | Total: 22 cu. ft.<br>Refrigerator:<br>12.5 cu. ft.<br>Freezer:<br>6.6 cu. ft. | Total: 23 cu. ft.<br>Refrigerator:<br>12.9 cu. ft.<br>Freezer:<br>6.6 cu. ft. | Total: 23 cu. ft.<br>Refrigerator:<br>12.9 cu. ft.<br>Freezer:<br>6.6 cu. ft. | Total: 30 cu. ft.<br>Refrigerator:<br>16.6 cu. ft.<br>Freezer:<br>9 cu. ft. | Total: 28 cu. ft.<br>Refrigerator:<br>15.6 cu. ft.<br>Freezer:<br>8.3 cu. ft. | Total: 28 cu. ft.<br>Refrigerator:<br>15.6 cu. ft.<br>Freezer:<br>8.3 cu. ft. | Total: 22 cu. ft.<br>Refrigerator:<br>12.6 cu. ft.<br>Freezer:<br>6.5 cu. ft. | Total: 28 cu. ft.<br>Refrigerator:<br>15.7 cu. ft.<br>Freezer:<br>8.3 cu. ft. | Total: 22 cu. ft.<br>Refrigerator:<br>12.8 cu. ft.<br>Freezer:<br>6.5 cu. ft. | Total: 28 cu. ft.<br>Refrigerator:<br>15.98 cu. ft.<br>Freezer:<br>8.35 cu. ft. | Total: 25 cu. ft.<br>Refrigerator:<br>13.98 cu. ft.<br>Freezer:<br>7.32 cu. ft. | Total: 24 cu. ft.<br>Refrigerator:<br>13 cu. ft.<br>Freezer:<br>6.5 cu. ft. |
| <b>Family Hub™</b>                  | ✓ (2.0)   | ✓ (2.0)   |   |   |   | ✓ (3.0)   | ✓ (3.0)   |   |   |   |   |   |   |
| <b>Food Showcase</b>                |   |   |   |   |   |   |   | ✓   | ✓   |   |   |   |   |
| <b>Counter Depth</b>                | ✓   | ✓   | ✓   | ✓   |   |   | ✓   |   | ✓   |   |   | ✓   |   |
| <b>Dispenser</b>                    | Ice & Water<br>Auto Fill<br>Water Pitcher                                     | Ice & Water<br>Auto Fill<br>Water Pitcher                                     | Ice & Water<br>Auto Fill<br>Water Pitcher                                     | Ice & Water<br>Auto Fill<br>Water Pitcher                                     | Ice & Water   | Ice & Water   | Ice & Water   | Ice & Water   | Ice & Water   | Ice & Water   | Ice & Water   | Ice & Water   |   |
| <b>Cooling System</b>               | Twin Cooling<br>Plus™   | Twin Cooling<br>Plus™   | Twin Cooling<br>Plus™   | Twin Cooling<br>Plus™   | Twin Cooling<br>Plus™   | Twin Cooling<br>Plus™   | Twin Cooling<br>Plus™   | Twin Cooling<br>Plus™   | Twin Cooling<br>Plus™   | Twin Cooling<br>Plus™   | Twin Cooling<br>Plus™   | Twin Cooling<br>Plus™   |   |
| <b>Metal Cooling</b>                | ✓   |   | ✓   |   |   | ✓   | ✓   | ✓   | ✓   |   |   |   |   |
| <b>Ice Production &amp; Storage</b> | 4.8 lbs/day;<br>2.7 lbs   | 4.8 lbs/day;<br>2.7 lbs   | 4.8 lbs/day;<br>2.7 lbs   | 4.8 lbs/day;<br>2.7 lbs   | 10 lbs/day;<br>4.2 lbs  | 10 lbs/day;<br>4.2 lbs  | 4.8 lbs/day;<br>2.7 lbs   | 10 lbs/day;<br>4.2 lbs  | 5.2 lbs/day;<br>2.7 lbs   | 10 lbs/day;<br>4.2 lbs  | 10 lbs/day;<br>4.2 lbs  | 5.2 lbs/day;<br>2.7 lbs   |   |
| <b>LED Lighting</b>                 | HE LED  | HE LED  | LED   | LED   | HE LED  | HE LED  | HE LED  | HE LED  | HE LED  | HE LED  | HE LED  | HE LED  |   |
| <b>FlexZone™</b>                    | ✓   | ✓   | ✓   | ✓   | ✓   | ✓   | ✓   | ✓   | ✓   | ✓   | ✓   | ✓   |   |
| <b>Water Filter</b>                 | HAF-QIN<br>DA97-17376B  | HAF-QIN<br>DA97-17376B  | HAF-QIN<br>DA97-17376B  | HAF-QIN<br>DA97-17376B  | HAF-CIN<br>DA29-00020B  | HAF-CIN<br>DA29-00020B  | HAF-CIN<br>DA29-00020B  | HAF-CIN<br>DA29-00020B  | HAF-CIN<br>DA29-00020B  | HAF-CIN<br>DA29-00020B  | HAF-CIN<br>DA29-00020B  | HAF-CIN<br>DA29-00020B  |   |
| <b>Door Handles</b>                 | Polygon   | Recessed  | Polygon   | Recessed  | Standard Round  | Standard Round  | Standard Round  | Standard Round  | Standard Round  | Standard Round  | Standard Round  | Standard Round  |   |
| <b>EZ-Open™</b>                     | ✓   |   | ✓   |   | ✓   | ✓   | ✓   | ✓   | ✓   | ✓   | ✓   | ✓   |   |
| <b>ENERGY STAR®</b>                 | CEE Tier 1  | CEE Tier 1  | CEE Tier 1  | CEE Tier 1  | CEE Tier 1  | CEE Tier 1  | CEE Tier 1  | CEE Tier 1  | CEE Tier 1  | CEE Tier 1  | CEE Tier 1  | CEE Tier 1  |   |
| <b>Sabbath Mode</b>                 |   |   | ★   | ★   |   |   |   |   |   |   |   |   |   |
| <b>Power Ratings</b>                | 115V / 60 Hz /<br>6 Amps  | 115V / 60 Hz /<br>6 Amps  | 115V / 60 Hz /<br>6 Amps  | 115V / 60 Hz /<br>6 Amps  | 115V / 60 Hz /<br>5.3 Amps  | 115V / 60 Hz /<br>5.3 Amps  | 115V / 60 Hz /<br>5.3 Amps  | 115V / 60 Hz /<br>5.3 Amps  | 115V / 60 Hz /<br>5.3 Amps  | 115V / 60 Hz /<br>5.3 Amps  | 115V / 60 Hz /<br>5.3 Amps  | 115V / 60 Hz /<br>5.3 Amps  |   |
| <b>Color Options</b>                | Stainless*,<br>Black Stainless*   | Stainless*,<br>Black Stainless*   | Stainless*,<br>Black Stainless*   | Stainless*,<br>Black Stainless*   | Stainless,<br>Black Stainless*  | Stainless,<br>Black Stainless*  | Stainless,<br>Black Stainless*  | Stainless,<br>Black Stainless*  | Stainless,<br>Black Stainless*  | Stainless,<br>Black Stainless*,<br>White                                      | Stainless,<br>Black Stainless*,<br>White  | Stainless   |   |
| <b>Dimensions (WxHxD)</b>           | 35 <sup>5</sup> / <sub>4</sub> " x 70" x 30 <sup>1</sup> / <sub>2</sub> "     | 35 <sup>5</sup> / <sub>4</sub> " x 70" x 29 <sup>9</sup> / <sub>4</sub> "     | 35 <sup>5</sup> / <sub>4</sub> " x 70" x 30 <sup>1</sup> / <sub>2</sub> "     | 35 <sup>5</sup> / <sub>4</sub> " x 70" x 29 <sup>9</sup> / <sub>4</sub> "     | 35 <sup>5</sup> / <sub>4</sub> " x 70" x 37 <sup>7</sup> / <sub>8</sub> "   | 35 <sup>5</sup> / <sub>4</sub> " x 70" x 36 <sup>1</sup> / <sub>2</sub> "     | 35 <sup>5</sup> / <sub>4</sub> " x 70" x 31"                                  | 35 <sup>5</sup> / <sub>4</sub> " x 70" x 36 <sup>1</sup> / <sub>2</sub> "     | 35 <sup>5</sup> / <sub>4</sub> " x 70" x 31"                                  | 35 <sup>5</sup> / <sub>4</sub> " x 70" x 36 <sup>1</sup> / <sub>2</sub> "     | 32 <sup>3</sup> / <sub>4</sub> " x 70" x 36 <sup>1</sup> / <sub>2</sub> "       | 35 <sup>5</sup> / <sub>4</sub> " x 70" x 31"                                    |   |

\*Fingerprint-resistant finish





# Refrigerators

## 3-Door French Door





| Model                               | RF265BEAE   | RF23HTEDB   | RF28HDEDB/P   | RF23HCEDB   | RF28HFEDB   | RF26J7500   | RF263BEAE   | RF261BEAE   | RF260BEAE   | RF220NCTA  | RF20HFENB  | RF18HFENB   |
|-------------------------------------|---|---|---|---|---|---|---|---|---|--|--|---|
| <b>Capacity</b>                     | Total: 24 cu. ft.<br>Refrigerator:<br>16.2 cu. ft.<br>Freezer:<br>8 cu. ft. | Total: 23 cu. ft.<br>Refrigerator:<br>15.6 cu. ft.<br>Freezer:<br>6.9 cu. ft. | Total: 28 cu. ft.<br>Refrigerator:<br>18.9 cu. ft.<br>Freezer:<br>8.9 cu. ft. | Total: 23 cu. ft.<br>Refrigerator:<br>15.7 cu. ft.<br>Freezer:<br>6.8 cu. ft. | Total: 28 cu. ft.<br>Refrigerator:<br>19.1 cu. ft.<br>Freezer:<br>8.9 cu. ft. | Total: 26 cu. ft.<br>Refrigerator:<br>17.8 cu. ft.<br>Freezer:<br>7.7 cu. ft. | Total: 25 cu. ft.<br>Refrigerator:<br>16.6 cu. ft.<br>Freezer:<br>8 cu. ft. | Total: 26 cu. ft.<br>Refrigerator:<br>17.5 cu. ft.<br>Freezer:<br>8 cu. ft. | Total: 26 cu. ft.<br>Refrigerator:<br>17.5 cu. ft.<br>Freezer:<br>8 cu. ft. | Total: 22 cu. ft.<br>Refrigerator:<br>14.8 cu. ft.<br>Freezer:<br>7 cu. ft.                            | Total: 20 cu. ft.<br>Refrigerator:<br>12.8 cu. ft.<br>Freezer:<br>6.6 cu. ft.                          | Total: 18 cu. ft.<br>Refrigerator:<br>11.8 cu. ft.<br>Freezer:<br>5.7 cu. ft.                           |
| <b>Family Hub™</b>                  | ✓ (2.0)   |   |   |   |   |   |   |   |   |  |  |   |
| <b>Food Showcase</b>                |   | ✓   | ✓   |   |   |   |   |   |   |  |  |   |
| <b>Counter Depth</b>                |   | ✓   |   | ✓   |   |   |   |   |   |  |  | ✓   |
| <b>Dispenser</b>                    | Ice & Water   | Ice & Water   | Ice & Water   | Ice & Water   | Ice & Water   | Ice & Water   | Ice & Water   | Internal Water  |   |  |  |   |
| <b>Cooling System</b>               | Twin Cooling Plus™  | Twin Cooling Plus™  | Twin Cooling Plus™  | Twin Cooling Plus™  | Twin Cooling Plus™  | Twin Cooling Plus™  | Twin Cooling Plus™  | Twin Cooling Plus™  | Twin Cooling Plus™  | Mono Cooling   | Twin Cooling Plus™   | Twin Cooling Plus™  |
| <b>Metal Cooling</b>                |   | ✓   | ✓   |   |   |   |   |   |   |  |  |   |
| <b>Ice Production &amp; Storage</b> | 10 lbs/day;<br>4.2 lbs  | 5.2 lbs/day;<br>2.7 lbs   | 10 lbs/day;<br>4.2 lbs  | 5.2 lbs/day;<br>2.7 lbs   | 10 lbs/day;<br>4.2 lbs  | 9.9 lbs/day;<br>4.2 lbs   | 10 lbs/day;<br>4.2 lbs  | 2 lbs/day;<br>4.2 lbs   | 2 lbs/day;<br>4.2 lbs   | 3.7 lbs/day;<br>4.2 lbs  | 3.3 lbs/day;<br>5.5 lbs  | 3.3 lbs/day;<br>5.5 lbs   |
| <b>LED Lighting</b>                 | HE LED  | HE LED  | HE LED  | HE LED  | HE LED  | HE LED  | HE LED  | HE LED  | HE LED  | HE LED   | LED  | LED   |
| <b>Water Filter</b>                 | HAF-CIN<br>DA29-00020B  | HAF-CIN<br>DA29-00020B  | HAF-CIN<br>DA29-00020B  | HAF-CIN<br>DA29-00020B  | HAF-CIN<br>DA29-00020B  | HAF-CIN<br>DA29-00020B  | HAF-CIN<br>DA29-00020B  | HAF-CIN<br>DA29-00020B  | HAF-CIN<br>DA29-00020B  | HAF-CIN<br>DA29-00020B   |  |   |
| <b>Door Handles</b>                 | Standard Round  | Standard Round  | Standard Round  | Standard Round  | Standard Round  | Standard Round  | Standard Round  | Standard Round  | Standard Round  | Standard Round   | Standard Round   | Standard Round  |
| <b>EZ-Open™</b>                     | ✓   | ✓   | ✓   | ✓   | ✓   | ✓   | ✓   | ✓   | ✓   |  | ✓  | ✓   |
| <b>Additional Features</b>          | CoolSelect Pantry™  | CoolSelect Pantry™  | CoolSelect Pantry™  | CoolSelect Pantry™  | CoolSelect Pantry™  | CoolSelect Pantry™  | CoolSelect Pantry™  | CoolSelect Pantry™  | CoolSelect Pantry™  | Wide Open Pantry   | Movable Fresh Box  | Movable Fresh Box   |
| <b>ADA Compliant</b>                |   |   |   |   |   |   |   |   |   |  |  |   |
| <b>ENERGY STAR®</b>                 | CEE Tier 1  | ✓   | CEE Tier 1  | ✓   | CEE Tier 1  | ✓   | CEE Tier 2  | CEE Tier 1  | CEE Tier 1  | Meets Dept of Energy standards   | Meets Dept of Energy standards   | Meets Dept of Energy standards  |
| <b>Sabbath Mode</b>                 |   |   |   |   |   |   |   |   |   |  |  |   |
| <b>Power Ratings</b>                | 115V / 60 Hz /<br>5.3 Amps  | 115V / 60 Hz /<br>5.3 Amps  | 115V / 60 Hz /<br>5.3 Amps  | 115V / 60 Hz /<br>5.3 Amps  | 115V / 60 Hz /<br>5.3 Amps  | 115V / 60 Hz /<br>5.3 Amps  | 115V / 60 Hz /<br>5.3 Amps  | 115V / 60 Hz /<br>5.3 Amps  | 115V / 60 Hz /<br>5.3 Amps  | 115V / 60 Hz /<br>5.3 Amps   | 115V / 60 Hz /<br>1.1 Amps   | 115V / 60 Hz /<br>1.1 Amps  |
| <b>Color Options</b>                | Stainless,<br>Black Stainless*  | Stainless   | Stainless,<br>Black Stainless*,<br>White                                      | Stainless,<br>Black Stainless*,<br>White                                      | Stainless,<br>Black Stainless*,<br>White                                      | Stainless,<br>White   | Stainless,<br>Black Stainless*,<br>White                                    | Stainless,<br>Black Stainless*,<br>White                                    | Stainless,<br>Black Stainless*,<br>White                                    | Stainless,<br>Black Stainless*,<br>White   | Stainless,<br>Black Stainless*,<br>White   | Stainless,<br>Black Stainless*,<br>White  |
| <b>Dimensions (WxHxD)</b>           | 35 <sup>3</sup> / <sub>4</sub> " x 70" x 35 <sup>5</sup> / <sub>8</sub> "   | 35 <sup>3</sup> / <sub>4</sub> " x 70" x 31"                                  | 35 <sup>3</sup> / <sub>4</sub> " x 70" x 36"                                  | 35 <sup>3</sup> / <sub>4</sub> " x 70" x 31"                                  | 35 <sup>3</sup> / <sub>4</sub> " x 70" x 36"                                  | 32 <sup>3</sup> / <sub>4</sub> " x 70" x 36 <sup>1</sup> / <sub>2</sub> "     | 35 <sup>3</sup> / <sub>4</sub> " x 70" x 35 <sup>5</sup> / <sub>8</sub> "   | 35 <sup>3</sup> / <sub>4</sub> " x 70" x 35 <sup>5</sup> / <sub>8</sub> "   | 35 <sup>3</sup> / <sub>4</sub> " x 70" x 35 <sup>5</sup> / <sub>8</sub> "   | 29 <sup>5</sup> / <sub>4</sub> " x 66 <sup>3</sup> / <sub>4</sub> " x 36 <sup>1</sup> / <sub>4</sub> " | 32 <sup>3</sup> / <sub>8</sub> " x 70 <sup>1</sup> / <sub>8</sub> " x 32 <sup>1</sup> / <sub>2</sub> " | 32 <sup>3</sup> / <sub>8</sub> " x 70 <sup>1</sup> / <sub>8</sub> " x 30 <sup>9</sup> / <sub>16</sub> " |

\*Fingerprint-resistant finish



# Refrigerators Side-By-Side





| Model                               | RH22H9010  | RS22HDHPN  | RH25H5611  | RS25H5111   | RS25J500D   |
|-------------------------------------|--|--|--|---|---|
| <b>Capacity</b>                     | Total: 22 cu. ft.<br>Refrigerator: 14.3 cu. ft.<br>Freezer: 7.2 cu. ft.                                | Total: 22 cu. ft.<br>Refrigerator: 14.4 cu. ft.<br>Freezer: 7.9 cu. ft.      | Total: 25 cu. ft.<br>Refrigerator: 15.6 cu. ft.<br>Freezer: 9.1 cu. ft.                                | Total: 25 cu. ft.<br>Refrigerator: 15.3 cu. ft.<br>Freezer: 9.2 cu. ft.                                 | Total: 25 cu. ft.<br>Refrigerator: 15.7 cu. ft.<br>Freezer: 8.8 cu. ft.                                   |
| <b>Food Showcase</b>                | ✓  |  | ✓  |   |   |
| <b>Counter Depth</b>                | ✓  | ✓  |  |   |   |
| <b>Dispenser</b>                    | Ice & Water  | Ice & Water  | Ice & Water  | Ice & Water   | Ice & Water   |
| <b>Cooling System</b>               | Multi-Air Flow System  | Twin Cooling Plus™   | Twin Cooling Plus™   | Twin Cooling Plus™  | Mono Cooling  |
| <b>Metal Cooling</b>                | ✓  |  | ✓  |   |   |
| <b>Ice Production &amp; Storage</b> | 4.4 lbs/day;<br>5.5 lbs  | 4.4 lbs/day;<br>5.5 lbs  | 4.2 lbs/day;<br>5.5 lbs  | 4.2 lbs/day;<br>5.5 lbs   | 4.2 lbs/day;<br>8.1 lbs   |
| <b>Ice Maker Location</b>           | Freezer Door   | Freezer Door   | Freezer Door   | Freezer Door  | Freezer Compartment   |
| <b>LED Lighting</b>                 | HE LED   | LED Tower Lighting   | LED Tower Lighting   | LED Tower Lighting  | LED Lighting  |
| <b>Water Filter</b>                 | HAF-CIN<br>DA29-00020B   | HAF-CU1<br>DA29-00003G   | HAF-CIN<br>DA29-00020B   | HAF-CIN<br>DA29-00020B  | HAF-CIN<br>DA29-00020B  |
| <b>Door Handles</b>                 | Recessed   | Standard Round   | Standard Round   | Standard Round  | Standard Round  |
| <b>ADA Compliant</b>                |  | ✓  | ✓  | ✓   | ✓   |
| <b>ENERGY STAR®</b>                 | ✓  | ✓  | ✓  | ✓   | Meets Dept of Energy standards  |
| <b>Power Ratings</b>                | 115V / 60 Hz / 6 Amps  | 115V / 60 Hz / 6 Amps  | 115V / 60 Hz / 6 Amps  | 115V / 60 Hz / 6 Amps   | 115V / 60 Hz / 6 Amps   |
| <b>Color Options</b>                | Stainless*,<br>Black Stainless*  | Stainless,<br>White  | Stainless,<br>Black Stainless*,<br>White   | Stainless,<br>Black Stainless*,<br>White  | Stainless,<br>Black Stainless*, White<br>(Black available RS25J500DBC/BY)                                 |
| <b>Dimensions (WxHxD)</b>           | 35 <sup>7</sup> / <sub>8</sub> " x 69 <sup>3</sup> / <sub>4</sub> " x 28 <sup>1</sup> / <sub>4</sub> " | 35 <sup>15</sup> / <sub>16</sub> " x 70 <sup>3</sup> / <sub>16</sub> " x 30" | 35 <sup>3</sup> / <sub>4</sub> " x 69 <sup>7</sup> / <sub>8</sub> " x 36 <sup>5</sup> / <sub>8</sub> " | 35 <sup>3</sup> / <sub>4</sub> " x 69 <sup>7</sup> / <sub>8</sub> " x 36 <sup>3</sup> / <sub>16</sub> " | 35 <sup>3</sup> / <sub>4</sub> " x 69 <sup>15</sup> / <sub>16</sub> " x 36 <sup>3</sup> / <sub>16</sub> " |

\*Fingerprint-resistant finish





# Refrigerators

## Top-Freezer





| Model                               | RT21M6215  | RT18M6215  | RT21M6213  | RT18M6213  |
|-------------------------------------|--|--|--|--|
| <b>Capacity</b>                     | Total: 21 cu. ft.<br>Refrigerator: 15.4 cu. ft.<br>Freezer: 5.7 cu. ft.                                | Total: 18 cu. ft.<br>Refrigerator: 12.7 cu. ft.<br>Freezer: 4.9 cu. ft.                                | Total: 21 cu. ft.<br>Refrigerator: 15.4 cu. ft.<br>Freezer: 5.7 cu. ft.                                | Total: 18 cu. ft.<br>Refrigerator: 12.7 cu. ft.<br>Freezer: 4.9 cu. ft.                                |
| <b>Cooling System</b>               | Twin Cooling Plus™   | Twin Cooling Plus™   | Twin Cooling Plus™   | Twin Cooling Plus™   |
| <b>Ice Production &amp; Storage</b> | 3.75 lbs/day;<br>5.5 lbs   | 3.75 lbs/day;<br>5.5 lbs   | Optional Quick Connect Ice Maker<br>3.75 lbs/day;<br>5.5 lbs   | Optional Quick Connect Ice Maker<br>3.75 lbs/day;<br>5.5 lbs   |
| <b>FlexZone™</b>                    | ✓  | ✓  | ✓  | ✓  |
| <b>Door Handles</b>                 | Recessed   | Recessed   | Recessed   | Recessed   |
| <b>Additional Features</b>          | Reversible Door  | Reversible Door  | Reversible Door  | Reversible Door  |
| <b>ENERGY STAR®</b>                 | ✓  | ✓  | ✓  | ✓  |
| <b>Ice Maker</b>                    | Auto Ice Maker (Factory-installed)   | Auto Ice Maker (Factory-installed)   | Optional Ice Maker   | Optional Ice Maker   |
| <b>Sabbath Mode</b>                 | ★  | ★  | ★  | ★  |
| <b>Power Ratings</b>                | 115V / 60 Hz / 3.5 Amps  | 115V / 60 Hz / 3.5 Amps  | 115V / 60 Hz / 3.5 Amps  | 115V / 60 Hz / 3.5 Amps  |
| <b>Color Options</b>                | Stainless*,<br>Black Stainless*,<br>White  | Stainless*,<br>Black Stainless*,<br>White  | Stainless*,<br>Black Stainless*,<br>White  | Stainless*,<br>Black Stainless*,<br>White  |
| <b>Dimensions (WxHxD)</b>           | 32 <sup>7</sup> / <sub>8</sub> " x 67 <sup>3</sup> / <sub>4</sub> " x 31 <sup>7</sup> / <sub>8</sub> " | 28 <sup>3</sup> / <sub>4</sub> " x 66 <sup>3</sup> / <sub>4</sub> " x 31 <sup>7</sup> / <sub>8</sub> " | 32 <sup>7</sup> / <sub>8</sub> " x 67 <sup>3</sup> / <sub>4</sub> " x 31 <sup>7</sup> / <sub>8</sub> " | 28 <sup>3</sup> / <sub>4</sub> " x 66 <sup>3</sup> / <sub>4</sub> " x 31 <sup>7</sup> / <sub>8</sub> " |

\*Fingerprint-resistant finish





# Laundry

Download Spec Sheets and Line Drawings at [samsung.com/builder](https://samsung.com/builder)





### FlexWash™

Two washers in one lets you wash separate loads at the same time or independently.

### AddWash™

With AddWash™, you can conveniently add in forgotten garments after the cycle has begun, without starting all over again.



### activewash™

Add a sink to your laundry room for all your stain removal and pre-treating needs. Simply lift the sink to let items fall into the washer.

### ENERGY STAR® Certified

Eco-friendly and energy-efficient, Samsung dryers meet the government's strict energy efficiency standards.



### Multi-Steam™ Technology

Reduce wrinkles, odors, bacteria and static with powerful and flexible steam options.

### Vent Sensor

Detects duct blockages and reminds you to clean your vent.

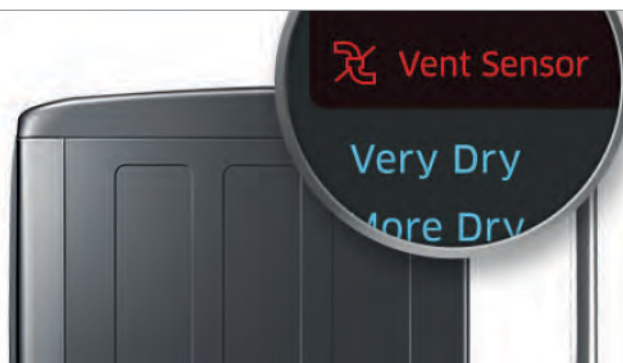



# WV60M9900/DV60M9900

FlexWash™ Washer + FlexDry™ Dryer

## Available Colors



Fingerprint  
Resistant Black  
Stainless Steel  
WV60M9900AV/A5  
DVE60M9900V/A3  
DVG60M9900V/A3



White  
WV60M9900AW/A5  
DVE60M9900W/A3  
DVG60M9900W/A3



## Washer

### FlexWash™

Two washers in one let you wash separate loads at the same time.

### 5.0 cu. ft. + 1.0 cu. ft. Capacity

Upper and lower washers mean fewer washes, less time in the laundry room and more time for you.

### Super Speed

Wash a full load in as little as 30 minutes – 50% faster.<sup>1</sup>

### Wi-Fi Connectivity

Remotely control and monitor your Samsung washer and dryer from anywhere using your mobile devices.<sup>2</sup>

## Dryer

### FlexDry™

Two dryers in one let you dry delicates and everyday garments at the same time.

### ENERGY STAR® Certified

Meets the strict energy efficiency specifications and standards.<sup>3</sup>

### Multi-Steam™ Technology

Steam away wrinkles, odors, bacteria and static.

### Delicate Dryer

Flat dry delicates, sweaters and accessories to prevent items from shrinking and fabric damage.

### Wi-Fi Connectivity

Remotely control and monitor your Samsung washer and dryer from anywhere using your mobile devices.<sup>2</sup>



<sup>1</sup>Normal 59-minute wash can now be completed in as little as 30 minutes as compared to WV55M9600 washer without Super Speed. Based on DOE standard's average of 7.5 loads per week.

<sup>2</sup>Only monitoring is allowed for gas dryer for safety reasons. Requires wireless network and Samsung SmartThings app. The Samsung SmartThings app supports Android OS 4.0 (ICS) or later which is optimized for Samsung smartphones (Galaxy S and Galaxy Note series). This app also supports iOS 7 or later for iPhone models. SmartThings app available in App Store and Play Store.

<sup>3</sup>Visit [www.energystar.gov](http://www.energystar.gov) for more information on ENERGY STAR® guidelines. Lower only.



# WV55M9600/DV55M9600

FlexWash™ Washer + FlexDry™ Dryer

## Available Colors



**Fingerprint Resistant Black Stainless Steel**  
WV55M9600AV/A5  
DV55M9600V/A3  
DVG55M9600V/A3

**White**  
WV55M9600AW/A5  
DV55M9600W/A3  
DVG55M9600W/A3



## Washer

### FlexWash™

Two washers in one let you wash separate loads at the same time.

### 4.5 cu. ft. + 1.0 cu. ft. Capacity

Upper and lower washers mean fewer washes, less time in the laundry room and more time for you.

### Steam Wash

Uses the power of steam to remove stains without pre-treatment.

### Wi-Fi Connectivity

Remotely control and monitor your Samsung washer and dryer from anywhere using your mobile devices.<sup>1</sup>

## Dryer

### FlexDry™

Two dryers in one let you dry delicates and everyday garments at the same time.

### ENERGY STAR® Certified

Meets the strict energy efficiency specifications and standards.<sup>2</sup>

### Multi-Steam™ Technology

Steam away wrinkles, odors, bacteria and static.

### Delicate Dryer

Flat dry delicates, sweaters and accessories to prevent items from shrinking and fabric damage.

### Wi-Fi Connectivity

Remotely control and monitor your Samsung washer and dryer from anywhere using your mobile devices.<sup>1</sup>



<sup>1</sup>Only monitoring is allowed for gas dryer for safety reasons. Requires wireless network and Samsung SmartThings app. The Samsung SmartThings app supports Android OS 4.0 (ICS) or later which is optimized for Samsung smartphones (Galaxy S and Galaxy Note series). This app also supports iOS 7 or later for iPhone models. SmartThings app available in App Store and Play Store.

<sup>2</sup>Visit [www.energystar.gov](http://www.energystar.gov) for more information on ENERGY STAR® guidelines. Lower only.



# WF50K7500/DV50K7500

AddWash™ Front-Load Washer and Dryer

## Available Colors



Fingerprint  
Resistant Black  
Stainless Steel  
WF50K7500AV/A2  
DV50K7500EV/A3  
DV50K7500GV/A3



White  
WF50K7500AW/A2  
DV50K7500EW/A3  
DV50K7500GW/A3



## Washer

### AddWash™

The convenient AddWash™ door lets you easily add forgotten laundry even after the cycle has started. No spills. No mess. No time or water wasted on a second cycle.

### 5.0 cu. ft. Capacity

Fewer washes, less time in the laundry room and more time for you.

### Super Speed

Wash a full load in as little as 30 minutes<sup>1</sup> – 50% faster, without sacrificing cleaning performance.

### PowerFoam™

PowerFoam™ technology uses an innovative mixture of water, air and detergent to penetrate deep into the heart of fabric. Confidently deep clean even your bulkiest items with the power of foam.

### Wi-Fi Connectivity

Remotely control and monitor your Samsung washer and dryer from anywhere using your mobile devices.<sup>2</sup>



## Dryer

### ENERGY STAR® Certified

Meets the strict energy efficiency specifications and standards.<sup>3</sup>

### 7.5 cu. ft. Capacity

Fewer loads, less time in the laundry room and more time for you.

### Multi-Steam™ Technology

Steam away wrinkles, odors, bacteria and static.

### Vent Sensor

Detects duct blockages and reminds you to clean your vent.

### Wi-Fi Connectivity

Remotely control and monitor your Samsung washer and dryer from anywhere using your mobile devices.<sup>2</sup>

<sup>1</sup>Normal 59-minute wash can now be completed in as little as 30 minutes as compared to WF42H5000 washer without Super Speed. Based on DOE standard's average of 7.5 loads per week.

<sup>2</sup>Only monitoring is allowed for gas dryer for safety reasons. Requires wireless network and Samsung SmartThings app. The Samsung SmartThings app supports Android OS 4.0 (ICS) or later which is optimized for Samsung smartphones (Galaxy S and Galaxy Note series). This app also supports iOS 7 or later for iPhone models. SmartThings app available in App Store and Play Store.

<sup>3</sup>Visit [www.energystar.gov](http://www.energystar.gov) for more information on ENERGY STAR® guidelines.



# WF45K6500/DV45K6500

AddWash™ Front-Load Washer and Dryer

## Available Colors



**Fingerprint Resistant Black Stainless Steel**  
WF45K6500AW/A2  
DV45K6500EW/A3

**White**  
WF45K6500AW/A2  
DV45K6500EW/A3



## Washer

### AddWash™

The convenient AddWash™ door lets you easily add forgotten laundry even after the cycle has started. No spills. No mess. No time or water wasted on a second cycle.

### 4.5 cu. ft. Capacity

Fewer washes, less time in the laundry room and more time for you.

### Super Speed

Wash a full load in as little as 36 minutes<sup>1</sup> – 35% faster, without sacrificing cleaning performance.

### Steam Wash

Uses the power of steam to remove stains without pre-treatment.

### Wi-Fi Connectivity

Remotely control and monitor your Samsung washer and dryer from anywhere using your mobile devices.<sup>2</sup>



## Dryer

### ENERGY STAR® Certified

Meets the strict energy efficiency specifications and standards.<sup>3</sup>

### 7.5 cu. ft. Capacity

Fewer loads, less time in the laundry room and more time for you.

### Multi-Steam™ Technology

Steam away wrinkles, odors, bacteria and static.

### Vent Sensor

Detects duct blockages and reminds you to clean your vent.

### Wi-Fi Connectivity

Remotely control and monitor your Samsung washer and dryer from anywhere using your mobile devices.<sup>2</sup>

<sup>1</sup>Normal 59-minute wash can now be completed in as little as 36 minutes as compared to WF42H5000 washer without Super Speed. Based on DOE standard's average of 7.5 loads per week.

<sup>2</sup>Only monitoring is allowed for gas dryer for safety reasons. Requires wireless network and Samsung SmartThings app. The Samsung SmartThings app supports Android OS 4.0 (ICS) or later which is optimized for Samsung smartphones (Galaxy S and Galaxy Note series). This app also supports iOS 7 or later for iPhone models. SmartThings app available in App Store and Play Store.

<sup>3</sup>Visit [www.energystar.gov](http://www.energystar.gov) for more information on ENERGY STAR® guidelines.





# WF45M5500/DV45M5500

Front-Load Washer and Dryer



## Washer

### Steam Wash

Uses the power of steam to remove stains without pre-treatment.

### 4.5 cu. ft. Capacity

Fewer washes, less time in the laundry room and more time for you.

### Vibration Reduction Technology Plus™

Reduces vibration 40% more than our standard VRT™ for quiet washing.

## Dryer

### ENERGY STAR® Certified

Meets the strict energy efficiency specifications and standards.\*

### 7.5 cu. ft. Capacity

Fewer loads, less time in the laundry room and more time for you.

### Multi-Steam™ Technology

Steam away wrinkles, odors, bacteria and static.

### Vent Sensor

Detects duct blockages and reminds you to clean your vent.



\*Visit [www.energystar.gov](http://www.energystar.gov) for more information on ENERGY STAR® guidelines.



# WF45N5300/DV45N5300

Front-Load Washer and Dryer

## Available Colors



Fingerprint  
Resistant Black  
Stainless Steel  
WF45N5300AV/US  
DVE45N5300V/A3  
DVG45N5300W/A3



White  
WF45N5300AW/US  
DVE45N5300W/A3  
DVG45N5300W/A3



## Washer

### Diamond Drum Interior

Drum design helps prevent fabrics from snagging and damage, allowing gentle fabric care with deep-clean results.

### 4.5 cu. ft. Capacity

Fewer washes, less time in the laundry room and more time for you.

### Vibration Reduction Technology Plus™

Reduces vibration 40% more than our standard VRT™ for quiet washing.

## Dryer

### Multi-Steam™ Technology

Steam away wrinkles, odors, bacteria and static.

### 7.5 cu. ft. Capacity

Fewer loads, less time in the laundry room and more time for you.

### Sensor Dry

Optimizes cycle time and temperature to dry clothes thoroughly while preventing heat damage.

### Smart Care

Smart Care interacts with your dryer to perform an immediate diagnosis and offer quick solutions.



# WF42H5000/DV42H5000

Front-Load Washer and Dryer

Available Color



White

WF42H5000AW/A2  
DV42H5000EW/A3  
DV42H5000GW/A3



## Washer

### Diamond Drum Interior

Drum design helps prevent fabrics from snagging and damage, allowing gentle fabric care with deep-clean results.

### 4.2 cu. ft. Capacity

Fewer washes, less time in the laundry room and more time for you.

### Vibration Reduction Technology™

Reduces vibration for quiet washing.

### Smart Care

Smart Care interacts with your dryer to perform an immediate diagnosis and offer quick solutions.

### Self Clean+

Keeps your washer fresh and odor-free without the use of harsh chemicals.



## Dryer

### Sensor Dry

Optimizes cycle time and temperature to dry clothes thoroughly while preventing heat damage.

### 7.5 cu. ft. Capacity

Fewer loads, less time in the laundry room and more time for you.

### Nine Preset Drying Cycles

Makes it easy to give each fabric type the right care needed for your family.

### Smart Care

Smart Care interacts with your dryer to perform an immediate diagnosis and offer quick solutions.



# WW22K6800/DV22K6800E/DV22N6800H

Front-Load Washer/Venter Dryer – Electric/Ventless Dryer – Heat Pump

## Available Color



White

WW22K6800AW/AZ  
DV22K6800EW/A1  
DV22N6800HW/AZ



## Washer

### Steam Wash

Uses the power of steam to remove stains without pre-treatment.

### 2.2 cu. ft. Capacity

Fewer washes, less time in the laundry room and more time for you.

### Vibration Reduction Technology Plus™

Reduces vibration 40% more than our standard VRT™ for quiet washing.

### Super Speed

Wash a full load in as little as 40 minutes<sup>1</sup> – 30% faster, without sacrificing cleaning performance.



## Dryer

### ENERGY STAR® Certified

Meets the strict energy efficiency specifications and standards.<sup>2</sup>

### 4.0 cu. ft. Capacity

Fewer loads, less time in the laundry room and more time for you.

### Smart Care

Smart Care interacts with your dryer to perform an immediate diagnosis and offer quick solutions.

### Sensor Dry

Optimizes cycle time and temperature to dry clothes thoroughly while preventing heat damage.

### 12 Preset Drying Cycles

Makes it easy to give each fabric type the right care needed for your family.

<sup>1</sup>Normal 58-minute wash can now be completed in as little as 40 minutes on the WW22K6800.

<sup>2</sup>Visit [www.energystar.gov](http://www.energystar.gov) for more information on ENERGY STAR® guidelines. Heat pump only.





# WW22N6850/DVE22N6850/DV22N6850H

Front-Load Washer/ Vented Dryer – Electric/Ventless Dryer – Heat Pump

## Available Color



Inox Grey

WW22N6850QX/AZ  
DVE22N6850X/AZ  
DV22N6850HX/AZ



## Washer

### QuickDrive™

QuickDrive™ reduces washing time by up to 35%, without compromising the cleaning performance<sup>1</sup>. Its Q-Drum™ has a main drum and a backplate that rotate independently, amplifying water movement so that clothes are cleaned gently, quickly and powerfully.

### 2.2 cu. ft. Capacity

Fewer washes, less time in the laundry room and more time for you.

### Q-rator

Q-rator is a smart management system that uses data captured during user interactions<sup>2</sup> to utilize QuickDrive™ more effectively. Laundry Recipe recommends optimal wash cycles. Laundry Planner helps optimize your laundry schedule. HomeCare Wizard enables remote troubleshooting.

### PowerFoam™

Our unique PowerFoam™ technology uses an innovative mixture of water, air and detergent to penetrate deep into the heart of fabric. Confidently deep clean even your bulkiest items with the power of foam.



## Dryer

### ENERGY STAR® Certified

Meets the strict energy efficiency specifications and standards.<sup>3</sup>

### 4.0 cu. ft. Capacity

Fewer loads, less time in the laundry room and more time for you.

### Smart Care

Smart Care interacts with your dryer to perform an immediate diagnosis and offer quick solutions.

### Sensor Dry

Optimizes cycle time and temperature to dry clothes thoroughly while preventing heat damage.

### 14 Preset Drying Cycles

Makes it easy to give each fabric type the right care needed for your family.

<sup>1</sup>Tested on Samsung WW6850N compared with WW6800K. Saves up to 35% time on Heavy Duty (hot, 6-lb load) with a washing performance equal to or better than WW6800K, based on UL data referring to AHAM HLW-1-2013

<sup>2</sup>A Samsung application account is necessary and available on Android and iPhone devices. A network connection is required. App stores user data, preferences and usage patterns to suggest the useful options. Q-rator available Washer and Heat pump dryer only.

<sup>3</sup>Visit [www.energystar.gov](http://www.energystar.gov) for more information on ENERGY STAR® guidelines. Heat pump only.



# WA54M8750/DV54M8750

activewash™ Top-Load Washer and Dryer with Integrated Touch Controls

## Available Colors



Fingerprint  
Resistant Black  
Stainless Steel  
WA54M8750AV/A4  
DVE54M8750V/A3  
DVG54M8750V/A3



White  
WA54M8750AW/A4  
DVE54M8750W/A3  
DVG54M8750W/A3



## Washer

### activewash™

A built-in sink right inside your washer for all your stain removal and pre-treating needs.

### 5.4 cu. ft. Capacity

Fewer washes, less time in the laundry room and more time for you.

### Steam Wash

Uses the power of steam for easy stain removal and a deeper clean.

## Dryer

### ENERGY STAR® Certified

Meets the strict, energy efficiency specifications and standards.\*

### 7.4 cu. ft. Capacity

Fewer loads, less time in the laundry room and more time for you.

### Multi-Steam™ Technology

Steam away wrinkles, odors, bacteria and static.

### Vent Sensor

Detects duct blockages and reminds you to clean your vent.



\*Visit [www.energystar.gov](http://www.energystar.gov) for more information on ENERGY STAR® guidelines.



# WA52M8650/DV52M8650

activewash™ Top-Load Washer and Dryer with Integrated Controls

## Available Colors



Fingerprint  
Resistant Black  
Stainless Steel  
WA52M8650AV/A4  
DV52M8650V/A3  
DVG52M8650V/A3



White  
WA52M8650AW/A4  
DV52M8650W/A3  
DVG52M8650W/A3



## Washer

### activewash™

A built-in sink right inside your washer for all your stain removal and pre-treating needs.

### 5.2 cu. ft. Capacity

Fewer washes, less time in the laundry room and more time for you.

### Super Speed

Wash a full load in as little as 36 minutes – 35% faster.<sup>1</sup>

### Vibration Reduction Technology Plus™

Reduces vibration 40% more than our standard VRT™ for quiet washing.

## Dryer

### ENERGY STAR® Certified

Meets the strict, energy efficiency specifications and standards.<sup>2</sup>

### 7.4 cu. ft. Capacity

Fewer loads, less time in the laundry room and more time for you.

### Multi-Steam™ Technology

Steam away wrinkles, odors, bacteria and static.

### Eco Dry

Uses up to 25% less energy for every load.



<sup>1</sup>Normal 56-minute wash can now be completed in as little as 36 minutes with Super Speed on the WA52M8650.

<sup>2</sup>Visit [www.energystar.gov](http://www.energystar.gov) for more information on ENERGY STAR® guidelines.



# WA52M7750/DV52M7750

activewash™ Top-Load Washer and Dryer

## Available Colors



Fingerprint  
Resistant Black  
Stainless Steel  
WA52M7750AV/A4  
DVE52M7750V/A3  
DVG52M7750V/A3



White  
WA52M7750AW/A4  
DVE52M7750W/A3  
DVG52M7750W/A3



## Washer

### activewash™

A built-in sink right inside your washer for all your stain removal and pre-treating needs.

### 5.2 cu. ft. Capacity

Fewer washes, less time in the laundry room and more time for you.

### Steam Wash

Uses the power of steam for easy stain removal and a deeper clean.

### Vibration Reduction Technology Plus™

Reduces vibration 40% more than our standard VRT™ for quiet washing.

## Dryer

### ENERGY STAR® Certified

Meets the strict, energy efficiency specifications and standards.\*

### 7.4 cu. ft. Capacity

Fewer loads, less time in the laundry room and more time for you.

### Multi-Steam™ Technology

Steam away wrinkles, odors, bacteria and static.

### Eco Dry

Uses up to 25% less energy for every load.



\*Visit [www.energystar.gov](http://www.energystar.gov) for more information on ENERGY STAR® guidelines.





# WA50M7450/DV50M7450

Top-Load Washer and Dryer

## Available Color



White

WA50M7450AW/A4  
DV50M7450W/A3  
DVG50M7450W/A3



## Washer

### 5.0 cu. ft. Capacity

Fewer washes, less time in the laundry room and more time for you.

### Self Clean+

Keeps your washer fresh and odor-free without the use of harsh chemicals.

### Vibration Reduction Technology Plus™

Reduces vibration 40% more than our standard VRT™ for quiet washing.

---

## Dryer

### 7.4 cu. ft. Capacity

Fewer loads, less time in the laundry room and more time for you.

### Multi-Steam™ Technology

Steam away wrinkles, odors, bacteria and static.

### Eco Dry

Uses up to 25% less energy for every load.

### Sensor Dry

Optimizes cycle time and temperature to dry clothes thoroughly while preventing heat damage.



# WA45M7050/DV45H7000

Top-Load Washer and Dryer

Available Color



White

WA45M7050AW/A4  
DV45H7000EW/A2  
DV45H7000GW/A2



## Washer

### 4.5 cu. ft. Capacity

Fewer washes, less time in the laundry room and more time for you.

### Self Clean

Keeps your washer fresh and odor-free without the use of harsh chemicals.

### Vibration Reduction Technology Plus™

Reduces vibration 40% more than our standard VRT™ for quiet washing.

---

## Dryer

### 7.4 cu. ft. Capacity

Fewer loads, less time in the laundry room and more time for you.

### Sensor Dry

Optimizes cycle time and temperature to dry clothes thoroughly while preventing heat damage.

### Nine Preset Drying Cycles

Makes it easy to give each fabric type the right care needed for your family.



# WA45N3050AW/DV40J3000

Top-Load Washer and Dryer

Available Color



White

WA45N3050AW/A4  
DV40J3000EW/A2  
DV40J3000GW/A2

## Washer

### 4.5 cu. ft. Capacity

Fewer washes, less time in the laundry room and more time for you.

### Self Clean

Keeps your washer fresh and odor-free without the use of harsh chemicals.

### Diamond Drum Interior

Drum design helps prevent fabrics from snagging and damage, allowing gentle fabric care with deep-clean results.

---

## Dryer

### 7.2 cu. ft. Capacity

Fewer loads, less time in the laundry room and more time for you.

### Sensor Dry

Optimizes cycle time and temperature to dry clothes thoroughly while preventing heat damage.

### Eight Preset Drying Cycles

Makes it easy to give each fabric type the right care needed for your family.



Laundry  
Front Load







| Model                                 | WV60M9900/<br>DV60M9900                        | WV55M9600/<br>DV55M9600                        | WF50K7500/<br>DV50K7500                      | WF45K6500/<br>DV45K6500                      | WF45M5500/<br>DV45M5500                      | WF45N5300/<br>DV45N5300                      | WF42H5000/<br>DV42H5000                      | WW22N6850/<br>DVE22N6850 (Vented - Electric) /<br>DV22N6850H (Ventless - Heat Pump)                    | WW22K6800/<br>DV22K6800E (Vented - Electric) /<br>DV22N6800H (Ventless - Heat Pump)                    |
|---------------------------------------|--|--|--|--|--|--|--|--|--|
| Capacity                              | 5.0 cu. ft. (Lower),<br>1.0 cu. ft. (Upper)    | 4.5 cu. ft. (Lower),<br>1.0 cu. ft. (Upper)    | 5.0 cu. ft.                                  | 4.5 cu. ft.                                  | 4.5 cu. ft.                                  | 4.5 cu. ft.                                  | 4.2 cu. ft.                                  | 2.2 cu. ft.  | 2.2 cu. ft.  |
| FlexWash™                             | ✓  | ✓  |  |  |  |  |  |  |  |
| AddWash™                              |  |  | ✓  | ✓  |  |  |  |  |  |
| Super Speed                           | ✓ (Lower)                                      |  | ✓  | ✓  |  |  |  | ✓  | ✓  |
| Wi-Fi                                 | Integrated                                     | Integrated                                     | Adapter required                             | Adapter required                             |  |  |  |  |  |
| PowerFoam™                            | ✓ (Lower)                                      |  | ✓  |  |  |  |  | ✓  |  |
| VRT™                                  | VRT Plus™ (Lower), VRT™ (Upper)                |  | VRT Plus™                                    | VRT Plus™                                    | VRT Plus™                                    | VRT Plus™                                    | VRT™   | VRT Plus™  | VRT Plus™  |
| Q-rator,<br>QuickDrive™<br>Technology |  |  |  |  |  |  |  | ✓  |  |
| Steam                                 | ✓ (Lower)                                      | ✓ (Lower)                                      | ✓  | ✓  | ✓  |  |  | ✓  | ✓  |
| Self Clean+                           | Self Clean+ (Lower), Self Clean (Upper)        |  | ✓  | ✓  | ✓  | ✓  | ✓  | ✓  | Self Clean   |
| Internal Heater                       | Lower only                                     | Lower only                                     | ✓  | ✓  | ✓  |  |  | ✓  | ✓  |
| Smart Care (W&D)                      | ✓  | ✓  | ✓  | ✓  | ✓  | ✓  | ✓  | ✓  | ✓  |
| Cycles                                | 12 (Lower), 5 (Upper)                          | 9 (Lower), 5 (Upper)                           | 14   | 14   | 10   | 8  | 8  | 14   | 12   |
| RPM                                   | 1300 (Lower), 800 (Upper)                      |  | 1300   | 1300   | 1300   | 1300   | 1200   | 1400   | 1400   |
| ENERGY STAR®                          | CEE Tier 2 (Lower)                             |  | CEE Tier 2                                   | CEE Tier 1                                   | CEE Tier 2                                   | CEE Tier 2                                   | CEE Tier 1                                   | CEE Tier 2   | CEE Tier 1   |
| Drum                                  | Swirl (Lower),<br>Conv. (Upper)                | Diamond (Lower),<br>Conv. (Upper)              | Swirl  | Diamond                                      | Diamond                                      | Diamond                                      | Diamond                                      | Swirl+   | Diamond  |
| LED Display                           | Ice Blue                                       | Ice Blue                                       | Ice Blue                                     | Ice Blue                                     | Ice Blue                                     | Ice Blue                                     | Ice Blue                                     | Ice Blue   | Ice Blue   |
| Door Design                           | Crystal Blue                                   | Crystal Blue                                   | AddWash™ Door                                | AddWash™ Door                                | Crystal Blue                                 | Chrome                                       | White  | Crystal Blue   | Crystal Blue   |
| Dimensions (WxHxD)                    | 27" x 46 <sup>15</sup> / <sub>16</sub> " x 34" | 27" x 46 <sup>15</sup> / <sub>16</sub> " x 34" | 27" x 38 <sup>3</sup> / <sub>4</sub> " x 34" | 27" x 38 <sup>3</sup> / <sub>4</sub> " x 34" | 27" x 38 <sup>3</sup> / <sub>4</sub> " x 34" | 27" x 38 <sup>3</sup> / <sub>4</sub> " x 34" | 27" x 38 <sup>3</sup> / <sub>4</sub> " x 33" | 23 <sup>5</sup> / <sub>8</sub> " x 33 <sup>1</sup> / <sub>2</sub> " x 27 <sup>1</sup> / <sub>8</sub> " | 23 <sup>5</sup> / <sub>8</sub> " x 33 <sup>1</sup> / <sub>2</sub> " x 26 <sup>5</sup> / <sub>8</sub> " |
| Color Options                         | Black Stainless*, White                        | Black Stainless*, White                        | Black Stainless*, White                      | Black Stainless*, White                      | Platinum, White,<br>Azure Blue               | Black Stainless*, White                      | White  | Inox Grey  | White  |

#### DRYER FEATURES

|                    |   |   |   |  |  |  |  |  |  |
|--------------------|---|---|---|--|--|--|--|--|--|
| Capacity           | 7.5 cu. ft. (Tumble Dryer)  |   | 7.5 cu. ft.   | 7.5 cu. ft.  | 7.5 cu. ft.  | 7.5 cu. ft.  | 7.5 cu. ft.  | 4.0 cu. ft.  | 4.0 cu. ft.  |
| FlexDry™           | ✓   | ✓   |   |  |  |  |  |  |  |
| Steam              | ✓ (Tumble Dryer)  | ✓ (Tumble Dryer)  | ✓   | ✓  | ✓  | ✓  |  |  |  |
| Cycles             | 12 (Tumble Dryer),<br>4 (Delicate Dryer)                                    | 9 (Tumble Dryer),<br>4 (Delicate Dryer)                                     | 14  | 14   | 10   | 10   | 9  | 14   | 12   |
| ENERGY STAR®       | ✓ (Tumble Dryer)  | ✓ (Tumble Dryer)  | ✓   | ✓  | ✓  |  |  | ✓ (Heat Pump)  | ✓ (Heat Pump)  |
| Dimensions (WxHxD) | 27" x 46 <sup>15</sup> / <sub>16</sub> " x 32 <sup>1</sup> / <sub>2</sub> " | 27" x 46 <sup>15</sup> / <sub>16</sub> " x 32 <sup>1</sup> / <sub>2</sub> " | 27" x 38 <sup>3</sup> / <sub>4</sub> " x 32 <sup>5</sup> / <sub>8</sub> " | 27" x 38 <sup>3</sup> / <sub>4</sub> " x 32 <sup>7</sup> / <sub>16</sub> " | 27" x 38 <sup>3</sup> / <sub>4</sub> " x 32 <sup>7</sup> / <sub>16</sub> " | 27" x 38 <sup>3</sup> / <sub>4</sub> " x 32 <sup>7</sup> / <sub>16</sub> " | 27" x 38 <sup>3</sup> / <sub>4</sub> " x 32 <sup>7</sup> / <sub>16</sub> " | 23 <sup>5</sup> / <sub>8</sub> " x 33 <sup>1</sup> / <sub>2</sub> " x 25 <sup>13</sup> / <sub>16</sub> " | 23 <sup>5</sup> / <sub>8</sub> " x 33 <sup>1</sup> / <sub>2</sub> " x 25 <sup>13</sup> / <sub>16</sub> " |
| Power Rating       | 120V / 60 Hz / 15 Amps  | 120V / 60 Hz / 15 Amps  | 120V / 60 Hz / 15 Amps  | 120V / 60 Hz / 15 Amps   | 120V / 60 Hz / 15 Amps   | 120V / 60 Hz / 15 Amps   | 120V / 60 Hz / 15 Amps   | 120V / 60 Hz / 15 Amps<br>240V / 60 Hz / 30 Amps<br>(Ventless - Heat Pump)                               | 120V / 60 Hz / 15 Amps<br>240V / 60 Hz / 30 Amps<br>(Ventless - Heat Pump)                               |

#### OPTIONAL ACCESSORIES

|                |       |       |          |          |          |          |          |   |   |
|----------------|-------|-------|----------|----------|----------|----------|----------|---|---|
| Stacking Kit   |       |       | ✓        | ✓        | ✓        | ✓        | ✓        | ✓ | ✓ |
| Riser/Pedestal | Riser | Riser | Pedestal | Pedestal | Pedestal | Pedestal | Pedestal |   |   |

\*Fingerprint-resistant finish

Risers: WE272NW - White, WE272NV - Black Stainless

Pedestals: WE357A0W, WE357A8W - White, WE357A0V - Black Stainless, WE357A0P - Platinum, WE357A0Z - Azure Blue



Laundry  
Top Load





| Model                 | WA54M8750/DV54M8750   | WA52M8650/DV52M8650   | WA52M7750/DV52M7750                           | WA50M7450/DV50M7450                           | WA45M7050/DV45H7000  | WA45N3050AW/DV40J3000                         |
|-----------------------|---|---|---|---|--|---|
| Capacity              | 5.4 cu. ft.   | 5.2 cu. ft.   | 5.2 cu. ft.                                   | 5.0 cu. ft.                                   | 4.5 cu. ft.  | 4.5 cu. ft.                                   |
| Activewash™           | ✓   | ✓   | ✓   |   |  |   |
| Super Speed           | ✓   | ✓   |   |   |  |   |
| Wi-Fi                 | Integrated  |   |   |   |  |   |
| VRT™/VRT Plus™        | VRT Plus™   | VRT Plus™   | VRT Plus™                                     | VRT Plus™                                     | VRT Plus™  | VRT Plus™                                     |
| Steam                 | ✓   |   | ✓   |   |  |   |
| Self Clean            | ✓   | ✓   | ✓   | ✓   | ✓  | ✓   |
| Internal Heater       | ✓   |   | ✓   |   |  |   |
| Smart Care            | ✓   | ✓   | ✓   | ✓   |  |   |
| Cycles                | 12  | 12  | 13  | 11  | 9  | 8   |
| RPM                   | 800   | 800   | 800   | 800   | 800  | 700   |
| ENERGY STAR®          | ✓   | ✓   | ✓   | ✓   | ✓  |   |
| Drum                  | Swirl   | Swirl   | Swirl   | Diamond                                       | Diamond  | Diamond                                       |
| Pulsator              | Stainless Steel   | Stainless Steel   | Stainless Steel                               | Stainless Steel                               | PP   | PP  |
| Control Panel         | Touch Inmold  | Tact + Inmold   | Jog + Touch Inmold                            | Jog + Inmold                                  | Jog + Inmold   | Jog + Silk Print                              |
| LED Display/Color     | Ice Blue  | Ice Blue  | Ice Blue                                      | Ice Blue                                      | Ice Blue   | Red   |
| Door Design           | Transparent Curved Glass w/ Chrome Deco                                     | Transparent Curved Glass w/ Chrome Deco                                     | Transparent Glass w/ Chrome Deco              | Tinted Glass w/ Chrome Deco                   | Tinted Glass w/ Chrome Deco  | Solid   |
| Dimensions (WxHxD)    | 27" x 42 <sup>7</sup> / <sub>16</sub> " x 29 <sup>5</sup> / <sub>16</sub> " | 27" x 42 <sup>7</sup> / <sub>16</sub> " x 29 <sup>5</sup> / <sub>16</sub> " | 27" x 46" x 29 <sup>5</sup> / <sub>16</sub> " | 27" x 45" x 29 <sup>5</sup> / <sub>16</sub> " | 27" x 43 <sup>15</sup> / <sub>16</sub> " x 29 <sup>5</sup> / <sub>16</sub> " | 27" x 44" x 29 <sup>5</sup> / <sub>16</sub> " |
| Color Options         | Black Stainless*, White   | Black Stainless*, White   | Black Stainless*, White                       | White   | White  | White   |
| <b>DRYER FEATURES</b> |   |   |   |   |  |   |
| Capacity              | 7.4 cu. ft.   | 7.4 cu. ft.   | 7.4 cu. ft.                                   | 7.4 cu. ft.                                   | 7.4 cu. ft.  | 7.2 cu. ft.                                   |
| Steam                 | ✓   | ✓   | ✓   | ✓   |  |   |
| Cycles                | 12  | 12  | 13  | 11  | 9  | 8   |
| ENERGY STAR®          | ✓   | ✓   | ✓   |   |  |   |
| Dimensions (WxHxD)    | 27" x 42 <sup>7</sup> / <sub>16</sub> " x 30 <sup>1</sup> / <sub>4</sub> "  | 27" x 42 <sup>7</sup> / <sub>16</sub> " x 30 <sup>1</sup> / <sub>4</sub> "  | 27" x 46" x 30"                               | 27" x 45" x 30"                               | 27" x 43 <sup>7</sup> / <sub>8</sub> " x 30"                                 | 27" x 44" x 30"                               |
| Power Ratings         | 120V / 60 Hz / 15 Amps  | 120V / 60 Hz / 15 Amps  | 120V / 60 Hz / 15 Amps                        | 120V / 60 Hz / 15 Amps                        | 120V / 60 Hz / 15 Amps   | 120V / 60 Hz / 15 Amps                        |

\*Fingerprint-resistant finish





# Vacuums

Download Spec Sheets and Line Drawings at [samsung.com/builder](https://samsung.com/builder)





## Powerful Robotic Suction

Delivers optimal cleaning results.



## Edge Clean Master

Thoroughly cleans corners and edges of the wall.



## Self-Clean Brush

Automatically removes hair tangles around the brush.

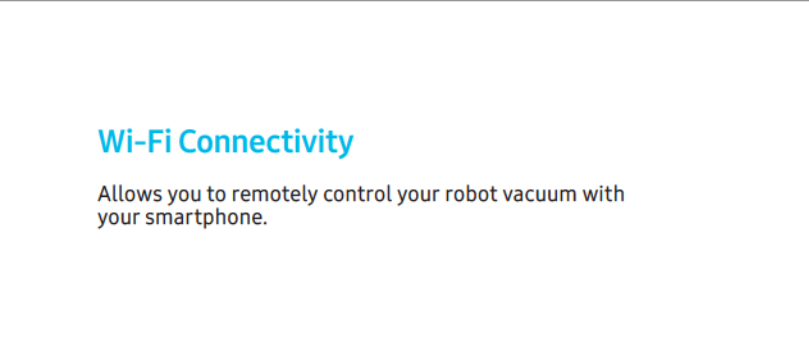

## Wi-Fi Connectivity

Allows you to remotely control your robot vacuum with your smartphone.

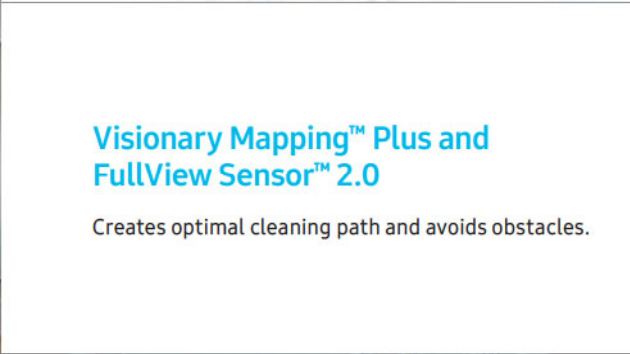

## Visionary Mapping™ Plus and FullView Sensor™ 2.0

Creates optimal cleaning path and avoids obstacles.



## CycloneForce™ Technology

Get consistent power with less clogging.\* Strong centrifugal forces separate dirt and debris into an outer chamber to maintain long-lasting suction power.

\* Tested internally on Samsung POWERbot VR7000 and Samsung conventional VR10F71UCAC



## VR2AK9350WK

POWERbot Turbo Robotic Vacuum

Available Color



Ebony Copper  
VR2AK9350WK/AA

### World's Most Powerful Robotic Suction

Delivers 70x more powerful cleaning on all floor types when compared to a conventional robot vacuum with a circular design.<sup>1</sup>

### Visionary Mapping™ Plus and FullView Sensor™ 2.0

Creates optimal cleaning path and avoids obstacles.

### CycloneForce™ Technology

More consistent power with less clogging.<sup>2</sup>

### Point Cleaning™

Simply point for on-demand vacuum cleaning.

### Wi-Fi Connectivity with Select & Go

Remotely select rooms you want to clean with your smartphone.

<sup>1</sup>Tested internally on Samsung POWERbot VR9000 and Samsung conventional VR10F71UCAC  
<sup>2</sup>Than our previous model



## VR2AJ9250WW

POWERbot Robotic Vacuum

Available Color



Airborne Copper  
VR2AJ9250WW/AA

### 50x More Powerful Robotic Suction

Delivers 50x more powerful cleaning on all floor types when compared to a conventional robot vacuum with a circular design.

### Visionary Mapping™ Plus and FullView Sensor™ 2.0

Creates optimal cleaning path and avoids obstacles.

### CycloneForce™ Technology

More consistent power with less clogging.<sup>2</sup>

### Point Cleaning™

Simply point for on-demand vacuum cleaning.

### Wi-Fi Connectivity

Remotely control your robotic vacuum with your smartphone.

<sup>1</sup>Tested internally on Samsung POWERbot VR9000 and Samsung conventional VR10F71UCAC  
<sup>2</sup>Than our previous model



# VR2AM7090WD

POWERbot Pet Robotic Vacuum

Available Color



Satin Gold  
VR2AM7090WD/AA

### 40x More Powerful Robotic Suction

Delivers 40x more powerful cleaning on all floor types when compared to a conventional robot vacuum with a circular design.<sup>1</sup>

### Edge Clean Master

An innovative rubber blade extends out to clean hard-to-reach areas, like corners and along the edges of the wall.

### Self-Clean Brush

Automatically detangles and removes pet hair that collects around the brush.

### Visionary Mapping™ Plus and FullView Sensor™ 2.0

Onboard camera and multiple sensors create the ideal cleaning path for multi-room cleaning while avoiding obstacles along the way. Coverage map shows you where POWERbot has cleaned.

### Wi-Fi Connectivity

Remotely control your robot vacuum on your smartphone<sup>2</sup> or through voice-enabled devices such as Bixby, Amazon Alexa or the Google Assistant.<sup>3</sup>

<sup>1</sup>Tested internally on Samsung POWERbot VR7000 and Samsung conventional VR10F71UCAC

<sup>2</sup>Through SmartThings app

<sup>3</sup> Amazon Alexa devices, Bixby devices and the Google Assistant devices sold separately



# VR2AM7070WS

POWERbot Pet Robotic Vacuum

Available Color



Satin Titanium  
VR2AM7070WS/AA

### 40x More Powerful Robotic Suction

Delivers 40x more powerful cleaning on all floor types when compared to a conventional robot vacuum with a circular design.<sup>1</sup>

### Edge Clean Master

An innovative rubber blade extends out to clean hard-to-reach areas, like corners and along the edges of the wall.

### Self-Clean Brush

Automatically detangles and removes pet hair that collects around the brush.

### Visionary Mapping™ Plus and FullView Sensor™ 2.0

Onboard camera and multiple sensors create the ideal cleaning path for multi-room cleaning while avoiding obstacles along the way. Coverage map shows you where POWERbot has cleaned.

### Wi-Fi Connectivity

Remotely control your robot vacuum on your smartphone<sup>2</sup> or through voice-enabled devices such as Bixby, Amazon Alexa or the Google Assistant.<sup>3</sup>

<sup>1</sup>Tested internally on Samsung POWERbot VR7000 and Samsung conventional VR10F71UCAC

<sup>2</sup>Through SmartThings app

<sup>3</sup> Amazon Alexa devices, Bixby devices and the Google Assistant devices sold separately



Vacuums



# VR2AM7065WS

POWERbot Robotic Vacuum

#### Available Color



Satin Titanium  
VR2AM7065WS/AA

#### 40x More Powerful Robotic Suction

Delivers 40x more powerful cleaning on all floor types when compared to a conventional robot vacuum with a circular design.<sup>1</sup>

#### Edge Clean Master

An innovative rubber blade extends out to clean hard-to-reach areas, like corners and along the edges of the wall.

#### Visionary Mapping™ Plus and FullView Sensor™ 2.0

Onboard camera and multiple sensors create the ideal cleaning path for multi-room cleaning while avoiding obstacles along the way. Coverage map shows you where POWERbot has cleaned.

#### Wi-Fi Connectivity

Remotely control your robot vacuum on your smartphone<sup>2</sup> or through voice-enabled devices such as Bixby, Amazon Alexa or the Google Assistant.<sup>3</sup>

<sup>1</sup>Tested internally on Samsung POWERbot VR7000 and Samsung conventional VR10F71UCAC

<sup>2</sup>Through SmartThings app

<sup>3</sup>Amazon Alexa devices, Bixby devices and the Google Assistant devices sold separately



# VR1AM7040WG

POWERbot Robotic Vacuum

#### Available Color



Neutral Gray  
VR1AM7040WG/AA

#### 20x More Powerful Robotic Suction

Delivers 20x more powerful cleaning on all floor types when compared to a conventional robot vacuum with a circular design.<sup>1</sup>

#### Edge Clean Master

An innovative rubber blade extends out to clean hard-to-reach areas, like corners and along the edges of the wall.

#### Visionary Mapping™ Plus and FullView Sensor™ 2.0

Onboard camera and multiple sensors create the ideal cleaning path for multi-room cleaning while avoiding obstacles along the way. Coverage map shows you where POWERbot has cleaned.

#### CycloneForce™ Technology

More consistent power with less clogging.<sup>2</sup>

#### Wi-Fi Connectivity

Remotely control your robot vacuum on your smartphone<sup>3</sup> or through voice-enabled devices such as Bixby, Amazon Alexa or the Google Assistant.<sup>4</sup>

<sup>1</sup>Tested internally on Samsung POWERbot VR7000 and Samsung conventional VR10F71UCAC

<sup>2</sup>Than our previous model

<sup>3</sup>Through SmartThings app

<sup>4</sup>Amazon Alexa devices, Bixby devices and the Google Assistant devices sold separately





# Vacuums





| Model  | VR2AK9350WK  | VR2AJ9250WW   | VR2AM7090WD  | VR2AM7070WS  | VR2AM7065WS  | VR1AM7040WG  |
|--|--|---|--|--|--|--|
| <b>Suction Power</b>   | World's Most Powerful <sup>1</sup>   | 50X More Powerful <sup>1</sup>  | 40X More Powerful <sup>2</sup>   | 40X More Powerful <sup>2</sup>   | 40X More Powerful <sup>2</sup>   | 20X More Powerful <sup>2</sup>   |
| <b>Visionary Mapping™ Plus &amp; FullView™ Sensor 2.0</b>            | ✓  | ✓   | ✓  | ✓  | ✓  | ✓  |
| <b>Wi-Fi (Works With Amazon Alexa, Google Assistant &amp; Bixby)</b> | ✓<br>w/ Select & Go  | ✓   | ✓  | ✓  | ✓  | ✓  |
| <b>Edge Clean</b>  | ✓  | ✓   | Edge Clean Master  | Edge Clean Master  | Edge Clean Master  | Edge Clean Master  |
| <b>Full Width Brush</b>  | Combo Brush  | Combo Brush   | Self Clean Brush   | Self Clean Brush   | Combo Brush  | Combo Brush  |
| <b>CycloneForce™ Technology</b>                                      | ✓  | ✓   | ✓  | ✓  | ✓  | ✓  |
| <b>Point Cleaning™</b>   | ✓  | ✓   | ✓  |  |  |  |
| <b>EasyPass Wheels™</b>  | ✓  | ✓   | ✓  | ✓  | ✓  | ✓  |
| <b>Scheduling</b>  | ✓  | ✓   | ✓  | ✓  | ✓  | ✓  |
| <b>Clear Dust Canister</b>   | Large  | Large   | Medium   | Medium   | Medium   | Medium   |
| <b>Intelligent Power Control</b>                                     | Corner   | Corner  | Corner/Carpet/Hard Floor   | Corner/Carpet/Hard Floor   | Corner/Carpet/Hard Floor   | Corner/Carpet/Hard Floor   |
| <b>Washable Filter</b>   | ✓  | ✓   | ✓  | ✓  | ✓  | ✓  |
| <b>Motor Warranty</b>  | 10 Years   | 10 Years  | 1 Year   | 1 Year   | 1 Year   | 1 Year   |
| <b>Cleaning Time</b>   | Up to 90 min   | Up to 90 min  | Up to 90 min   | Up to 90 min   | Up to 90 min   | Up to 60 min   |
| <b>Recharging Time</b>   | 240 min  | 160 min   | 160 min  | 160 min  | 160 min  | 240 min  |
| <b>Cleaning Modes</b>  | Auto, Repeat, Manual, Spot   | Auto, Repeat, Manual, Spot  | Auto, Repeat, Manual, Spot   | Auto, Repeat, Manual, Spot   | Auto, Repeat, Manual, Spot   | Auto, Repeat, Manual, Spot   |
| <b>Display Type</b>  | 7 segment  | 7 segment   | 7 segment  | 7 segment  | 7 segment  | 7 segment  |
| <b>Remote Control</b>  | ✓  | ✓   | ✓  | ✓  | ✓  | ✓  |
| <b>Color Options</b>   | Ebony Copper   | Airborne Copper   | Satin Gold   | Satin Titanium   | Satin Titanium   | Neutral Gray   |
| <b>Dimensions</b>  | 14 <sup>7</sup> / <sub>8</sub> " x 5 <sup>5</sup> / <sub>16</sub> " x 14 <sup>1</sup> / <sub>4</sub> " | 14 <sup>15</sup> / <sub>16</sub> " x 5 <sup>5</sup> / <sub>16</sub> " x 14 <sup>5</sup> / <sub>16</sub> " | 13 <sup>7</sup> / <sub>16</sub> " x 3 <sup>13</sup> / <sub>16</sub> " x 13 <sup>3</sup> / <sub>4</sub> " | 13 <sup>7</sup> / <sub>16</sub> " x 3 <sup>13</sup> / <sub>16</sub> " x 13 <sup>3</sup> / <sub>4</sub> " | 13 <sup>7</sup> / <sub>16</sub> " x 3 <sup>13</sup> / <sub>16</sub> " x 13 <sup>3</sup> / <sub>4</sub> " | 13 <sup>7</sup> / <sub>16</sub> " x 3 <sup>13</sup> / <sub>16</sub> " x 13 <sup>3</sup> / <sub>4</sub> " |

<sup>1</sup>Tested internally on Samsung POWERbot VR9000 and Samsung conventional VR10F71UCAC.  
<sup>2</sup>Tested internally on Samsung POWERbot VR7000 and Samsung conventional VR10F71UCAC.



**SAMSUNG**



Designed to Simplify™  Whirlpool®



## Kitchen Colors and Finishes



G/W | White



P | Pure White



B | Black



T | Biscuit



C | Pure Biscuit



D | Universal Silver



F | Monochromatic Satina™ Steel



S | Stainless Steel



Y/M | Monochromatic Stainless Steel



R | Chrome



H | White Ice



E | Black Ice

**True innovation** takes the complexity out

## Laundry Colors



G/W | White

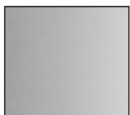

U | Diamond Steel



C | Chrome Shadow

---

We make it easy. Whether it's in the kitchen or the laundry room, Whirlpool® appliances will fit seamlessly into your home and your life. We balance the latest technology with effortless features that will exceed your expectations and change the way you think about appliances. Our innovations sense and adapt to your needs, so you can spend less time with your appliances and more time doing what you love.



## Whirlpool® Kitchen Stylist™ Tool

---

Inspiration and innovation become seamless with Whirlpool brand's new online interactive kitchen design tool. Now you can try out your favorite kitchen designs and appliances like never before. Select your personal kitchen style, configuration, wall colors and cabinets to see what your virtual kitchen will look like when enhanced with Whirlpool® appliances. When you're done, you can even save and share your kitchen with friends and family.



---

Visit [whirlpool.com/kitchen-stylist](http://whirlpool.com/kitchen-stylist) to get started now



# Whirlpool brand has the Seal

---

Select Whirlpool® appliances have earned the Good Housekeeping Seal. For over 100 years, the Seal has helped you feel confident about your product purchases. Look for the limited warranty reflected by the Good Housekeeping Seal throughout this catalog. If these select products become defective within the first two years of purchase, Good Housekeeping will replace the product, repair it or refund the purchase price.



Visit [goodhousekeeping.com/seal](http://goodhousekeeping.com/seal)  
for warranty details.



# Laundry made easy with Whirlpool™ WashSquad

---

Download the newest app from Whirlpool brand and make doing laundry a fun game the whole family can enjoy. Now you can assign tasks, enjoy tips and tricks and reward family members for completing the laundry just the way you want it from the palm of your hand.



## Whirlpool™ WashSquad

Search WHIRLPOOL in the App Store to download the newest laundry app from Whirlpool brand.











## REFRIGERATION

- 10 French door and classic bottom-freezer refrigerators
- 20 Side-by-side refrigerators
- 28 Top-freezer refrigerators
- 42 Upright and chest freezers
- 51 Automatic icemaker
- 52 Accessories
- 54 Glossary
- 56 Specifications



WRX988SIBM

## FRENCH DOOR REFRIGERATORS



### Most flexible storage\*

Select models feature a FreshStor™ refrigerated drawer, EasyView™ Triple Crisper system and Tri-freezer system, so you'll always have the perfect place to store bulk food purchases, small snacks, produce and whatever else you bring home from the grocery store.



### Innovative cooling

AccuFresh® dual cooling technology helps keep fruits and vegetables fresher and helps keep crystals off ice cream. It senses interior conditions and independently adapts cooling in both the refrigerator and freezer compartments so the ideal climate for fresh and frozen food is always maintained.

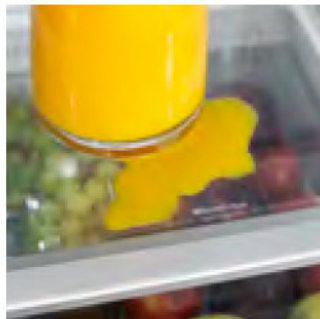

### Creates more space with innovative spill-control technology

Keep spills under control and prevent them from leaking onto other shelves with the MicroEdge® shelves' innovative spill-control technology. They also offer 25% more usable shelf space.\*\*



### Opens up refrigerator space

The In-Door-Ice® system creates room for an extra shelf in the refrigerator compartment by storing the ice bin in the door. A removable, clear ice bin lets you fill coolers with ease.

NOTE: Not all features are available on all models.

\*Among leading brand french door refrigerators with external refrigerated drawers based on combined refrigerator and freezer storage options and adjustable features. \*\*Compared to Whirlpool® french door models without MicroEdge® shelves.



## French Door Refrigerators



### WRF560SFY 20 cu. ft. W | B | M

- FreshFlow™ air filter and produce preserver
- ENERGY STAR® qualified
- Meets CEE Tier 2\* standards
- Adjustable gallon door bins
- Accu-Chill™ temperature management system
- SpillGuard™ glass refrigerator shelves
- Clear split-width humidity controlled crispers
- LED interior lighting



### WRF560SMY 20 cu. ft. W | B | M | H | E

- PUR® 6-month ice filtration**
- Condiment Caddy**
- Factory-installed icemaker**
- FreshFlow™ air filter and produce preserver
- ENERGY STAR® qualified
- Meets CEE Tier 2\* standards
- Adjustable gallon door bins
- Accu-Chill™ temperature management system
- SpillGuard™ glass refrigerator shelves
- Clear split-width humidity controlled crispers
- LED interior lighting

\*Based on the Consortium for Energy Efficiency qualifying product lists. Visit [cee1.org](http://cee1.org) for more information.

Step-up features highlighted by yellow bar



Most Whirlpool® refrigerators are ENERGY STAR® qualified.

## French Door Refrigerators



### **WRF560SEY 20 cu. ft. W | B | M**

- PUR® 6-month ice and water filtration
- Exterior water dispenser
- FreshFlow™ air filter and produce preserver
- ENERGY STAR® qualified
- Meets CEE Tier 2\* standards
- Adjustable gallon door bins
- Accu-Chill™ temperature management system
- SpillGuard™ glass refrigerator shelves
- Clear split-width humidity controlled crispers
- LED interior lighting
- Factory-installed icemaker



### **WRF535SMB 25 cu. ft. W | B | M** **WRF532SMB 22 cu. ft. W | B | M**

- FreshFlow™ produce preserver
- ENERGY STAR® qualified
- Adjustable gallon door bins
- Accu-Chill™ temperature management system
- Glass refrigerator shelves
- Clear humidity controlled crispers
- LED interior lighting
- Factory-installed icemaker

\*Based on the Consortium for Energy Efficiency qualifying product lists. Visit [cee1.org](http://cee1.org) for more information.

Feature descriptions can be found in the glossary on pages 54–55. Complete product specifications can be found on page 56.

## French Door Refrigerators

RATED A  
BEST  
BUY\*



### **GX5FHTXV 25 cu. ft. Q | B | Y**

Whirlpool Gold® model

Meets CEE Tier 1\*\* standards

PUR® 6-month ice and water filtration

Interior water dispenser

ENERGY STAR® qualified

Adjustable gallon door bin

Accu-Chill™ temperature management system

SpillGuard™ glass refrigerator shelves

Clear humidity controlled crispers

Factory-installed icemaker



### **GI6FARXX 26 cu. ft. Q | B | F | Y**

Whirlpool Gold® model

Tap Touch controls

Meets CEE Tier 2\*\* standards

Additional adjustable gallon door bins

Exterior ice and water dispenser

ENERGY STAR® qualified

PUR® 6-month ice and water filtration

Accu-Chill™ temperature management system

SpillGuard™ glass refrigerator shelves

Clear humidity controlled crispers

Factory-installed icemaker

\*According to a leading consumer magazine. \*\*Based on the Consortium for Energy Efficiency qualifying product lists. Visit [cee1.org](http://cee1.org) for more information.

Step-up features  
highlighted by  
yellow bar



Most Whirlpool® refrigerators  
are ENERGY STAR® qualified.

## French Door Refrigerators



### WRF736SDA 26 cu. ft. W | B | F | M

- Whirlpool Gold® model
- MicroEdge® glass refrigerator shelves
- In-Door-Ice® system
- Triple Crisper system
- Panoramic LED interior lighting
- FreshFlow™ air filter and produce preserver
- Tap Touch controls
- ENERGY STAR® qualified
- Meets CEE Tier 2\*\* standards
- Adjustable gallon door bins
- PUR® 6-month ice and water filtration
- Accu-Chill™ temperature management system



### WRF989SDA 29 cu. ft. W | B | F | M | H | E

- Whirlpool Gold® model
- AccuFresh® dual cooling technology
- Measured Fill
- MicroEdge® glass refrigerator shelves
- In-Door-Ice® system
- Triple Crisper system
- Panoramic LED interior lighting
- Tap Touch controls
- FreshFlow™ air filter and produce preserver
- ENERGY STAR® qualified
- Meets CEE Tier 2\*\* standards
- Adjustable gallon door bins
- PUR® 6-month ice and water filtration

\*\* Based on the Consortium for Energy Efficiency qualifying product lists. Visit [cee1.org](http://cee1.org) for more information.

Feature descriptions can be found in the glossary on pages 54–55. Complete product specifications can be found on pages 56–57.



## French Door Refrigerators



### **WRX735SDB 25 cu. ft. M**

Whirlpool Gold® model

External refrigerated drawer

Multiple snack compartments

Tap Touch controls

Measured Fill

ENERGY STAR® qualified

Meets CEE Tier 1\* standards

Adjustable gallon door bins

PUR® 6-month ice and water filtration

Accu-Chill™ temperature management system

SpillGuard™ glass refrigerator shelves

LED interior lighting

Factory-installed icemaker

\*Based on the Consortium for Energy Efficiency qualifying product lists. Visit [cee1.org](http://cee1.org) for more information.

Step-up features  
highlighted by  
yellow bar



Most Whirlpool® refrigerators  
are ENERGY STAR® qualified.

## French Door Refrigerators



### **WRX988SIB 28 cu. ft. W | B | M | H | E**

Whirlpool Gold® model

FreshStor™ refrigerated drawer

EasySlide bin

MicroEdge® glass refrigerator shelves

AccuFresh® dual cooling technology

In-Door-Ice® system

EasyView™ Triple Crisper system

Tri-freezer system

FreshFlow™ air filter and produce preserver

Panoramic LED interior lighting

Tap Touch controls

Measured Fill

ENERGY STAR® qualified

Meets CEE Tier 1\* standards

Adjustable gallon door bins

PUR® 6-month ice and water filtration

\*Based on the Consortium for Energy Efficiency qualifying product lists. Visit [cee1.org](http://cee1.org) for more information.

Feature descriptions can be found in the glossary on pages 54–55. Complete product specifications can be found on page 57.

## Counter Depth French Door Refrigerator



Image for feature reference only.  
Model not available in Black.



### **GI0FSAXV 20 cu. ft. Y**

- Whirlpool Gold® model
- Counter depth model: 70" height
- ENERGY STAR® qualified
- Meets CEE Tier 1\* standards
- Adjustable gallon door bins
- PUR® 6-month ice and water filtration
- Accu-Chill™ temperature management system
- SpillGuard™ glass refrigerator shelves
- Clear humidity controlled crispers
- Factory-installed icemaker

\*Based on the Consortium for Energy Efficiency qualifying product lists. Visit [cee1.org](http://cee1.org) for more information.

Step-up features  
highlighted by  
yellow bar



Most Whirlpool® refrigerators  
are ENERGY STAR® qualified.

## Bottom-Freezer Refrigerators



### **EB9SHKXV 19 cu. ft. Q**

- ENERGY STAR® qualified
- Meets CEE Tier 1\* standards
- Adjustable door bins
- Accu-Chill™ temperature management system
- Glass refrigerator shelves
- Clear humidity controlled crispers
- Reversible side-swing doors
- Factory-installed icemaker

**#1  
RATED\*\***



### **GB2FHDXW 22 cu. ft. Q | B | S** **GB9FHDXW 19 cu. ft. Q | B | S**

- Whirlpool Gold® model
- Meets CEE Tier 3\* standards
- Freezer drawer
- ENERGY STAR® qualified
- Adjustable door bins
- Accu-Chill™ temperature management system
- Glass refrigerator shelves
- Clear humidity controlled crispers
- Reversible side-swing door
- Factory-installed icemaker

\*Based on the Consortium for Energy Efficiency qualifying product lists. Visit [cee1.org](http://cee1.org) for more information. \*\*According to a leading consumer magazine, model GB2FHDXW only.

Feature descriptions can be found in the glossary on pages 54–55. Complete product specifications can be found on pages 58–59.





WRS965CIAH

## SIDE-BY-SIDE REFRIGERATORS



### Industry's largest capacity side-by-side refrigerator\*

Store all your favorite foods quickly and easily with leading capacity from Whirlpool brand. Select models offer gallon-size storage in the door and additional shelf and freezer space to make room for bulk food purchases and sheet cakes.



### Delivers more space with innovative spill-control technology

Keep spills under control and prevent them from leaking onto other shelves with the MicroEdge® shelves' innovative spill-control technology. They also offer 25% more usable shelf space.\*\*



### Cools food quickly

Save energy and cool your food quickly with the Accu-Chill™ temperature management system. This intuitive system senses and adapts using built-in sensors to save energy and deliver efficient cooling performance, while Adaptive Defrost saves more energy† by defrosting only when necessary.

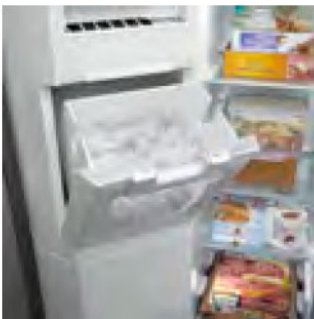

### Opens up freezer space

By placing the icemaker and removable ice bin in the door, the In-Door-Ice® Plus system creates 30% more usable space in the freezer.†† The ice bin also tilts out, or can be removed with one hand, to make filling glasses or pitchers with fresh, filtered ice easy.

NOTE: Not all features are available on all models.

\*Among freestanding side-by-side refrigerators. \*\*Compared to Whirlpool® side-by-side models without MicroEdge® shelves. †As compared to Whirlpool® side-by-side refrigerators without Adaptive Defrost. ††Compared to 26 cu. ft. Whirlpool® models with conventional icemakers.

## Side-by-Side Refrigerators



**WRS325FDA 25 cu. ft. W | B | T | D | M**  
**WRS322FDA 22 cu. ft. W | B | T | D | M**

- Accu-Chill™ temperature management system
- Glass refrigerator shelves
- LED interior lighting
- ENERGY STAR® qualified
- Meets CEE Tier 2\* standards
- PUR® 6-month ice and water filtration
- Adjustable gallon door bins
- Adaptive Defrost



**WRS342FIA 22 cu. ft. W | B | M**

- In-Door-Ice®** system
- Accu-Chill™ temperature management system
- Glass refrigerator shelves
- LED interior lighting
- ENERGY STAR® qualified
- Meets CEE Tier 2\* standards
- PUR® 6-month ice and water filtration
- Adjustable gallon door bins
- Adaptive Defrost

\*Based on the Consortium for Energy Efficiency qualifying product lists. Visit [cee1.org](http://cee1.org) for more information.

Step-up features highlighted by yellow bar



Most Whirlpool® refrigerators are ENERGY STAR® qualified.

## Side-by-Side Refrigerators



### **WSF26C2EX 26 cu. ft. W | B | F | Y**

- In-Door-Ice® Plus system
- FreshFlow™ air filter
- SpillGuard™ glass refrigerator shelves
- Accu-Chill™ temperature management system
- ENERGY STAR® qualified
- Meets CEE Tier 1\* standards
- PUR® 6-month ice and water filtration
- Adjustable gallon door bins
- Adaptive Defrost



### **WRS526SIA 26 cu. ft. H | E**

- Additional SpillGuard™ glass refrigerator shelf
- In-Door-Ice® Plus system
- Accu-Chill™ temperature management system
- Glass refrigerator shelves
- FreshFlow™ air filter
- ENERGY STAR® qualified
- Meets CEE Tier 1\* standards
- PUR® 6-month ice and water filtration
- Adjustable gallon door bins
- Adaptive Defrost

\*Based on the Consortium for Energy Efficiency qualifying product lists. Visit [cee1.org](http://cee1.org) for more information.

Feature descriptions can be found in the glossary on pages 54–55. Complete product specifications can be found on page 60.



## Side-by-Side Refrigerators



**WRS537SIA 27 cu. ft. W | B | F | M**

LED interior lighting

Tap Touch controls

In-Door-Ice® Plus system

Accu-Chill™ temperature management system

Glass refrigerator shelves

FreshFlow™ air filter

ENERGY STAR® qualified

Meets CEE Tier 3\* standards

PUR® 6-month ice and water filtration

Adjustable gallon door bins

Adaptive Defrost

\*Based on the Consortium for Energy Efficiency qualifying product lists. Visit [cee1.org](http://cee1.org) for more information.

Step-up features  
highlighted by  
yellow bar



Most Whirlpool® refrigerators  
are ENERGY STAR® qualified.

## Side-by-Side Refrigerators



### **WRS950SIA 30 cu. ft. M | H | E**

Whirlpool Gold® model

MicroEdge® glass refrigerator shelves

Panoramic LED interior lighting

In-Door-Ice® Plus system

Accu-Chill™ temperature management system

Tap Touch controls

FreshFlow™ air filter

ENERGY STAR® qualified

Meets CEE Tier 1\* standards

PUR® 6-month ice and water filtration

Adjustable gallon door bins

Adaptive Defrost

\*Based on the Consortium for Energy Efficiency qualifying product lists. Visit [cee1.org](http://cee1.org) for more information.

Feature descriptions can be found in the glossary on pages 54–55. Complete product specifications can be found on page 60.

## Counter Depth Side-by-Side Refrigerators



### **WRS321CDB 21 cu. ft. M**

- Counter depth model: 69" height
- Accu-Chill™ temperature management system
- FreshFlow™ air filter
- Glass refrigerator shelves
- PUR® 6-month ice and water filtration
- Adjustable gallon door bins
- Adaptive Defrost



### **GSC25C6EY 25 cu. ft. W | B | Y**

- Whirlpool Gold® model
- MicroEdge® glass refrigerator shelves
- In-Door-Ice® Plus system
- Panoramic LED interior lighting
- ENERGY STAR® qualified
- Meets CEE Tier 1\* standards
- Counter depth model: 72" height
- Accu-Chill™ temperature management system
- FreshFlow™ air filter
- PUR® 6-month ice and water filtration
- Adjustable gallon door bins
- Adaptive Defrost

\*Based on the Consortium for Energy Efficiency qualifying product lists. Visit [cee1.org](http://cee1.org) for more information.

Step-up features highlighted by yellow bar



Most Whirlpool® refrigerators are ENERGY STAR® qualified.

## Counter Depth Side-by-Side Refrigerators



### **WRS965CIA 25 cu. ft. M | H | E**

Whirlpool Gold® model

Tap Touch controls

Additional adjustable gallon door bins

Counter depth model: 69" height

MicroEdge® glass refrigerator shelves

In-Door-Ice® Plus system

Accu-Chill™ temperature management system

Panoramic LED interior lighting

FreshFlow™ air filter

ENERGY STAR® qualified

Meets CEE Tier 1\* standards

PUR® 6-month ice and water filtration

Adaptive Defrost

\*Based on the Consortium for Energy Efficiency qualifying product lists. Visit [cee1.org](http://cee1.org) for more information.

Feature descriptions can be found in the glossary on pages 54–55. Complete product specifications can be found on page 61.





WRT371SZBM

## TOP-FREEZER REFRIGERATORS



### Flexible innovations for fresh and frozen food

Select models feature storage innovations like the largest capacity pantry drawer available,\* a fold-away shelf and Tilt-N-Go door bins. Right Fit™ door bins also perfectly hold gallon-size containers. Now you can easily store groceries where you need them.



### Superior cooling performance

The temperature management system senses and adapts to deliver great food preservation. Adaptive Defrost saves up to 12% more energy\*\* by running the defrost cycle only when necessary and by monitoring how often the compressor operates and when the doors are open.

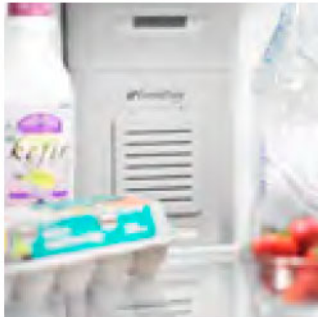

### Keeps food fresh

The FreshFlow™ air filter reduces common food odors by actively circulating air through the carbon-based filter. The FreshFlow™ produce preserver also helps keep produce fresh longer† by absorbing ethylene gas that causes produce to over-ripen more quickly.



### Puts filtered water in reach

Whirlpool brand offers the industry's only top-freezer refrigerator with an exterior dispenser and electronic controls. Select models offer cold, filtered water without opening the door and easy access to features.

NOTE: Not all features are available on all models.

\*Among leading brand top-freezer refrigerators with pantry drawers based on drawer volume. This is only applicable to 21 cu. ft. models.

\*\*As compared to previous Whirlpool® top-freezer models with Adaptive Defrost; based on 24-hour interval with refrigerator doors left unopened.

†Based on commonly purchased produce.

## Flat Door Top-Freezer Refrigerators



**W4TXNFW 14 cu. ft. Q | T**

- Wire refrigerator shelves
- White half-width crispers
- Automatic defrost system
- Optional icemaker



**W6TXNFW 16 cu. ft. Q | T**

- Wire refrigerator shelves
- White full-width crisper
- Automatic defrost system
- Optional icemaker

Step-up features highlighted by yellow bar



Most Whirlpool® refrigerators are ENERGY STAR® qualified.

## Flat Door Top-Freezer Refrigerators



**W5TXEWFV 15 cu. ft. Q | B**

- ENERGY STAR® qualified
- Meets CEE Tier 1\* standards
- Wire refrigerator shelves
- White full-width crisper
- Automatic defrost system
- Optional icemaker



**W8TXNWFB 18 cu. ft. Q | B | T**

- White half-width crispers
- Wire refrigerator shelves
- Automatic defrost system
- Optional icemaker

\*Based on the Consortium for Energy Efficiency qualifying product lists. Visit [cee1.org](http://cee1.org) for more information.

Feature descriptions can be found in the glossary on pages 54–55. Complete product specifications can be found on page 62.



## Flat Door Top-Freezer Refrigerators



**W8TXNWMB 18 cu. ft. Q | B**

- Factory-installed icemaker
- Wire refrigerator shelves
- White half-width crispers
- Automatic defrost system



**W8TXNGZB 18 cu. ft. Q | B | T**

- SpillMizer™ glass refrigerator and freezer shelves
- Clear half-width humidity controlled crispers
- Automatic defrost system
- Optional EZ Connect icemaker
- Sliding snack compartment

Actual image may vary

Step-up features highlighted by yellow bar



Most Whirlpool® refrigerators are ENERGY STAR® qualified.

## Flat Door Top-Freezer Refrigerators



### **W8TXEWFY 18 cu. ft. Q | B**

- ENERGY STAR® qualified
- Meets CEE Tier 1\* standards
- Wire refrigerator shelves
- Clear half-width crispers
- Automatic defrost system
- Optional icemaker



### **W8TXEGFY 18 cu. ft. Q | B**

- SpillMizer™ glass refrigerator shelves
- Clear half-width crispers
- ENERGY STAR® qualified
- Meets CEE Tier 1\* standards
- Automatic defrost system
- Optional icemaker

\*Based on the Consortium for Energy Efficiency qualifying product lists. Visit [cee1.org](http://cee1.org) for more information.

Feature descriptions can be found in the glossary on pages 54–55. Complete product specifications can be found on pages 62–63.

## Flat Door Top-Freezer Refrigerators



### **WRT138TFY 18 cu. ft. W | B | S**

- Clear split-width humidity controlled crispers
- ENERGY STAR® qualified
- Meets CEE Tier 1\* standards
- SpillMizer™ glass refrigerator shelves
- Automatic defrost system
- Optional icemaker

\*Based on the Consortium for Energy Efficiency qualifying product lists. Visit [cee1.org](http://cee1.org) for more information.

Step-up features  
highlighted by  
yellow bar



Most Whirlpool® refrigerators  
are ENERGY STAR® qualified.

## Flat Door Top-Freezer Refrigerators



### **WRT311FZB 21 cu. ft. M**

- Adjustable door bins
- SpillMizer™ glass refrigerator and freezer shelves
- Optional EZ Connect icemaker
- ENERGY STAR® qualified
- Meets CEE Tier 1\* standards
- Clear split-width humidity controlled crispers
- Automatic defrost system

\*Based on the Consortium for Energy Efficiency qualifying product lists. Visit [cee1.org](http://cee1.org) for more information.

Feature descriptions can be found in the glossary on pages 54–55. Complete product specifications can be found on page 63.



## Contoured Door Top-Freezer Refrigerators



### **WRT111SFA 11 cu. ft. W | B | F**

- SpillMizer™ glass refrigerator shelves
- Clear full-width humidity controlled crisper
- Adjustable gallon door bin
- Automatic defrost system
- Optional icemaker



### **W6RXNGFW 16 cu. ft. Q | B | S**

- SpillMizer™ glass refrigerator and freezer shelves
- Clear half-width humidity controlled crispers
- Sliding snack compartment
- Automatic defrost system
- Optional icemaker

Step-up features highlighted by yellow bar



Most Whirlpool® refrigerators are ENERGY STAR® qualified.

## Contoured Door Top-Freezer Refrigerators



### **W8RXNGMB 18 cu. ft. Q | B | D | S**

- Factory-installed icemaker
- SpillMizer™ glass refrigerator and freezer shelves
- Clear half-width humidity controlled crispers
- Automatic defrost system
- Sliding snack compartment



### **W8RXEGMW 18 cu. ft. Q | B | D | S**

- ENERGY STAR® qualified
- Meets CEE Tier 1\* standards
- Adjustable gallon door bins
- SpillMizer™ glass refrigerator and freezer shelves
- Clear half-width humidity controlled crispers
- Automatic defrost system
- Factory-installed icemaker
- Sliding snack compartment

\*Based on the Consortium for Energy Efficiency qualifying product lists. Visit [cee1.org](http://cee1.org) for more information.

Feature descriptions can be found in the glossary on pages 54–55. Complete product specifications can be found on page 64.

## Contoured Door Top-Freezer Refrigerators



### **WRT311SFY 21 cu. ft. W | B | T**

- Clear split-width humidity controlled crispers
- Adjustable Right Fit™ gallon door bins
- SpillMizer™ glass refrigerator shelves
- Automatic defrost system
- Optional icemaker



### **WRT359SFY 19 cu. ft. W | B | F | M**

- ENERGY STAR® qualified
- Meets CEE Tier 3<sup>†</sup> standards
- SpillMizer™ glass refrigerator shelves
- Clear split-width humidity controlled crispers
- Automatic defrost system
- Adjustable Right Fit™ gallon door bins

\*Based on the Consortium for Energy Efficiency qualifying product lists. Visit [cee1.org](http://cee1.org) for more information.

Step-up features highlighted by yellow bar



Most Whirlpool® refrigerators are ENERGY STAR® qualified.

## Contoured Door Top-Freezer Refrigerators



**WRT371S2B 21 cu. ft. W | B | F | M**

Optional EZ Connect icemaker

LED interior lighting

SpillMizer™ glass refrigerator shelves

Clear split-width humidity controlled crispers

ENERGY STAR® qualified

Meets CEE Tier 3\* standards

Automatic defrost system

Adjustable Right Fit™ gallon door bins

\*Based on the Consortium for Energy Efficiency qualifying product lists. Visit [cee1.org](http://cee1.org) for more information.

Feature descriptions can be found in the glossary on pages 54–55. Complete product specifications can be found on pages 64–65.



## Contoured Door Top-Freezer Refrigerators



### **WRT771RWY 21 cu. ft. W | B | M**

Whirlpool Gold® model

SpillMizer™ glass refrigerator and freezer shelves

Interior water dispenser

FreshFlow™ air filter and produce preserver

Adaptive Defrost

PUR® 6-month ice and water filtration

Factory-installed icemaker

Clear split-width humidity controlled crispers

ENERGY STAR® qualified

Meets CEE Tier 3\* standards

Adjustable Right Fit™ gallon door bins

\*Based on the Consortium for Energy Efficiency qualifying product lists. Visit [cee1.org](http://cee1.org) for more information.

Step-up features  
highlighted by  
yellow bar



Most Whirlpool® refrigerators  
are ENERGY STAR® qualified.

## Contoured Door Top-Freezer Refrigerators



RATED A  
RECOMMENDED BUY \*\*

### WRT771REY 21 cu. ft. W | B | M

Whirlpool Gold® model

Exterior water dispenser

Fast Cool option

SpillMizer™ glass refrigerator and freezer shelves

Clear split-width humidity controlled crispers

FreshFlow™ air filter and produce preserver

ENERGY STAR® qualified

Meets CEE Tier 1\* standards

Adaptive Defrost

Adjustable Right Fit™ gallon door bins

PUR® 6-month ice and water filtration

Factory-installed icemaker

\*Based on the Consortium for Energy Efficiency qualifying product lists. Visit [cee1.org](http://cee1.org) for more information. \*\*According to a leading consumer magazine.

Feature descriptions can be found in the glossary on pages 54–55. Complete product specifications can be found on page 65.



# FREEZERS



## Locks in freshness

Keep your favorite foods frozen longer\* during a power outage with Whirlpool® chest freezers. Select models keep cold air in when the power goes out, so food stays frozen for up to 17 hours when there's a power outage.\* That's one less thing you have to worry about.



## Flexible installation

Reversible upright freezer doors can be installed to open from the right or the left, depending on kitchen style and configuration, for added flexibility.



## Saves energy

The #1 rated brand for upright freezers\*\* also delivers nearly an entire lineup of ENERGY STAR® qualified models to choose from. Now it's even easier to store extra frozen food while using less energy, which saves money and helps the environment.



## Innovative storage strength

Whirlpool® chest freezers feature a solid core lid that is durable enough to support 250 lbs without harming the chest freezer.

NOTE: Not all features are available on all models.

\*Based on average performance of Whirlpool® 15 cu. ft. chest freezers using AHAM Household Refrigerator and Freezer Performance Testing (models EH151FXT and EH155FXB). \*\*Based on rating of Whirlpool® model EV161N2T among self-defrost upright freezers by a leading consumer magazine.



## Upright Freezers



### EV160FXB 16 cu. ft. Q

- ENERGY STAR® qualified
- Contoured door
- Interior light
- Wire shelves
- Fast Freeze
- Lower flip-down wire gate



### EV160NZT 16 cu. ft. Q

- Reversible, contoured door
- Frost-free defrost
- ENERGY STAR® qualified
- Interior light
- Wire shelves
- Fast Freeze
- Lower flip-down wire gate

Step-up features highlighted by yellow bar



Most Whirlpool® freezers are ENERGY STAR® qualified.

## Upright Freezers

#1  
RATED\*



### EV161NZT 16 cu. ft. Q

- Temperature alarm
- Lower wire basket
- ENERGY STAR® qualified
- Reversible, contoured door
- Interior light
- Wire shelves
- Frost-free defrost
- Fast Freeze



### EV180NZB 18 cu. ft. Q

- ENERGY STAR® qualified
- Reversible, contoured door
- Interior light
- Wire shelves
- Frost-free defrost
- Fast Freeze
- Lower flip-down wire gate

\*According to a leading consumer magazine.

Feature descriptions can be found in the glossary on pages 54–55. Complete product specifications can be found on page 66.

## Upright Freezers



### **EV200FXB 20 cu. ft. Q**

- Additional wire shelf
- ENERGY STAR® qualified
- Contoured door
- Interior light
- Fast Freeze
- Lower flip-down wire gate



### **EV200NQB 20 cu. ft. Q**

- Reversible, contoured door
- Frost-free defrost
- ENERGY STAR® qualified
- Interior light
- Wire shelves
- Fast Freeze
- Lower flip-down wire gate

Step-up features highlighted by yellow bar



Most Whirlpool® freezers are ENERGY STAR® qualified.

## Upright Freezers



### **EV201N2T 20 cu. ft. Q**

- Temperature alarm
- Adjustable door bins
- Gallon door shelf
- Lower wire basket
- ENERGY STAR® qualified
- Reversible, contoured door
- Interior light
- Frost-free defrost
- Wire shelves
- Fast Freeze

---

Feature descriptions can be found in the glossary on pages 54–55. Complete product specifications can be found on page 66.



## Chest Freezers



### **EH151FXT 15 cu. ft. Q**

- ENERGY STAR® qualified
- Solid core lid
- Rounded interior corners
- 5-sided freezer coils
- Large storage baskets
- Lid lock with key
- Defrost drain with hose adapter
- Integrated door handle design



### **EH155FXB 15 cu. ft. Q**

- Temperature alarm
- Interior light
- ENERGY STAR® qualified
- Solid core lid
- Rounded interior corners
- 5-sided freezer coils
- Large storage baskets
- Lid lock with key
- Defrost drain with hose adapter
- Integrated door handle design

Step-up features highlighted by yellow bar



Most Whirlpool® freezers are ENERGY STAR® qualified.

## Chest Freezers



### **EH185FXT 18 cu. ft. Q**

- Additional large storage basket
- ENERGY STAR® qualified
- Solid core lid
- Rounded interior corners
- 5-sided freezer coils
- Temperature alarm
- Interior light
- Lid lock with key
- Defrost drain with hose adapter
- Integrated door handle design



**RATED A  
RECOMMENDED BUY\***

### **EH225FXT 22 cu. ft. Q**

- ENERGY STAR® qualified
- Solid core lid
- Rounded interior corners
- 5-sided freezer coils
- Temperature alarm
- Interior light
- Large storage baskets
- Lid lock with key
- Defrost drain with hose adapter
- Integrated door handle design

\*According to a leading consumer magazine.

Feature descriptions can be found in the glossary on pages 54–55. Complete product specifications can be found on page 67.

## SideKicks® Upright Freezer & Refrigerator



### **EV188NYW (All Freezer) 18 cu. ft. Q | S**

- ENERGY STAR® qualified
- Meets CEE Tier 1\* standards
- Interior light
- Mid-level wire basket
- Lower wire basket
- Frost-free defrost
- Icemaker ready
- Installation wheels

### **EL88TRRW (All Refrigerator) 18 cu. ft. Q | S**

- ENERGY STAR® qualified
- Meets CEE Tier 1\* standards
- Interior light
- Gallon door bins
- Glass refrigerator shelves
- Installation wheels
- Clear humidity controlled crispers
- Clear dairy bins

\*Based on the Consortium for Energy Efficiency qualifying product lists. Visit [cee1.org](http://cee1.org) for more information.



Most Whirlpool® refrigerators and freezers are ENERGY STAR® qualified.

## Automatic Icemaker



### **GI15NDXZ Up to 25 lbs Q | B | S**

Whirlpool Gold® model  
PUR® 6-month ice filtration  
Reversible, flat door  
Fast Ice  
Service indicator  
Electronic Clean cycle  
Interior light  
Ice scoop

---

Feature descriptions can be found in the glossary on pages 54–55. Complete product specifications can be found on pages 68–69.



## Accessories



### FreshFlow™ Produce Preserver Starter Kit (P1FB6S1)

Help keep produce fresh longer\* inside the refrigerator. This starter kit fits in any refrigerator bin.



### FreshFlow™ Ice Cube & Freezer Deodorizer (4392894SRB)

Ideal for the high airflow and low moisture of the freezer, this deodorizer traps odors before they are frozen in ice cubes.



### FreshFlow™ Produce Preserver (FRESH1/W10346771A)

This replaceable cartridge provides 6 months of ethylene absorption in the crisper drawer, helping keep produce fresh longer.\*



### FreshFlow™ Refrigerator Deodorizer (8171398SRB)

Ideal for the low airflow and high moisture levels of the refrigerator, this deodorizer absorbs powerful refrigerator odors, like onion, garlic and fish.



### FreshFlow™ Air Filter (AIR1/W10311524)

This smart air filter is up to 15 times more effective than baking soda in reducing common food odors. Replace filter every 6 months for optimal performance.

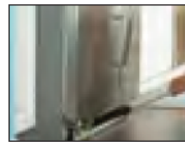

### Multi-Use Cleaning Brush (4210463RW)

Recommended for cleaning refrigerators, this brush helps save energy and ensures proper performance. Size 37-1/2" (L) x 2" (W) x 2" (D).

## Water Filters



**FILTER1 (W10295370A)**  
**FILTER2 (W10413645A)**  
**FILTER4 (UKF8001)**

NOTE: FILTER1 (W10295370) is being replaced by FILTER1 (W10295370A). Both filters are still valid and useable.

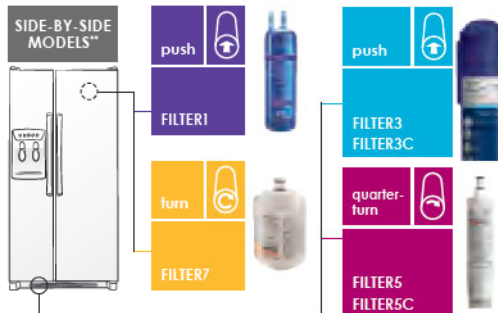

**FILTER1 (W10295370A)**  
**FILTER7 (UKF7003)**  
**FILTER3 (4396841)**  
**FILTER3C (4396710)**  
**FILTER5 (4396508)**  
**FILTER5C (4396510)**

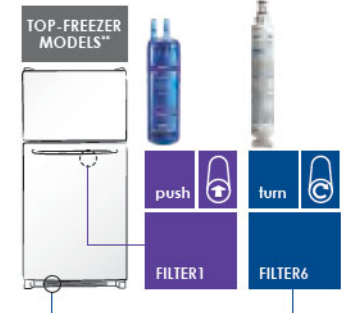

**FILTER1 (W10295370A)**  
**FILTER6 (4396701)**

To acquire pricing information, order Whirlpool® refrigeration accessories and determine delivery time, visit [whirlpool.com/accessories](http://whirlpool.com/accessories) or call 1-800-462-3819.

\*Based on commonly purchased produce. \*\*Built-in and drawer refrigerators not illustrated. See your refrigerator Use and Care Guide to confirm your water filter replacement number.

# Accessories

## Satina™ Stainless Look Finish and Stainless Steel Side Panels

- 1 side panel (fits either side on side-by-side and french door refrigerators)
- No tools required—kit includes everything you need for installation
- Satina™ stainless look finish resists fingerprints, accepts magnets and is easy to clean

| REFRIGERATOR MODEL  | STAINLESS STEEL | SATINA™ STAINLESS LOOK FINISH | DIMENSIONS           |
|---|-----------------|-------------------------------|----------------------|
| 23 cu. ft. Counter depth side-by-side refrigerators         | 4396748         | N/A                           | 24.24" W x 68.28" H  |
| 25 cu. ft. Counter depth side-by-side refrigerators         | 4396749         | N/A                           | 24.24" W x 71.125" H |
| 25 cu. ft. Contoured and classic side-by-side refrigerators | 4396351         | 8212633                       | 27.68" W x 68.33" H  |
| 20 cu. ft. Counter depth french door refrigerators          | W10194323       | N/A                           | 23.63" W x 68.31" H  |
| 25 cu. ft. Freestanding french door refrigerators           | W10136753       | W10137042                     | 28.63" W x 68.33" H  |

## SideKicks® Upright Freezer and Refrigerator Kits (See page 68 for product specifications)

- Easy to install and maintain
- Provide a built-in look without the built-in cost
- Adjustable height—install all grille extrusions or just the number of extrusions you want to create the height you desire

| AVAILABLE ACCESSORY                        | PART NUMBER | INCLUDED EXTRUSIONS  |
|--|-------------|--|
| Stainless Steel Trim Kit (18 cu. ft.)      | SKT60S      | Top trim extrusion (1), Grill extrusion (6), Notched grille extrusion (1), Right extrusion side trim (1), Left extrusion side trim (1), Styrofoam spacer (1), Grille bottom assembly (1), Front bracket (1) with Screws (4), Gap filler assembly and assorted screws |
| Stainless Steel Finishing Kit (18 cu. ft.) | SKFK60S     | Styrofoam spacer (1), Grille bottom assembly (1), Front bracket (1) with Screws (4), Gap filler assembly and assorted screws   |

## Side-by-Side Stainless Steel Top Cap

- No tools required—fits side-by-side refrigerators
- Adds 3" to refrigerator height
- Can be used with Satina™ stainless look finish or stainless steel side panels

| REFRIGERATOR MODEL                                  | PART NUMBER | DIMENSIONS                    |
|---|-------------|-------------------------------|
| 23 cu. ft. Counter depth side-by-side refrigerators | W10136975   | 2.62" H x 35.53" W x 27.06" D |
| 25 cu. ft. Counter depth side-by-side refrigerators | W10136975   | 2.62" H x 35.53" W x 27.06" D |
| 25 cu. ft. Freestanding side-by-side refrigerators  | W10136976   | 2.62" H x 35.53" W x 29.88" D |

(Cannot be used with contoured door refrigerators.)

## Optional Icemaker Kits

| REFRIGERATOR MODEL                         | INSTALLATION KIT | UNINSTALL KIT |
|--|------------------|---------------|
| 24" Width refrigerators                    | 24ECKMF          | —             |
| Side-by-side and top-freezer refrigerators | ECKMF94          | 4396928       |
| SideKicks® upright freezer                 | ECKMF94          | 4396928       |
| Bottom-freezer refrigerators               | IC13B            | —             |
| 30" Width french door refrigerator         | IC14B            | —             |

# Glossary

## **Accu-Chill™ temperature management system**

Built-in sensors measure the internal temperature and activate the compressor only when necessary to conserve energy while helping to keep food fresh.

## **AccuFresh® dual cooling technology**

This innovative dual evaporator system is found on select french door refrigerators. It helps keep fruits and vegetables fresher and helps keep crystals off ice cream. It uses the ideal humidity levels in the refrigerator and freezer compartments for improved food preservation.

## **ADA compliant**

Top-freezer refrigerators with this designation fully comply with federal guidelines for accommodating persons with disabilities.

## **Adaptive Defrost**

Monitors when the compressor is running and defrosts only when necessary, resulting in improved food preservation and energy savings.

## **Adjustable door storage**

Gives you the flexibility to store items anywhere in the refrigerator door by moving bins where and when you need them.

## **Automatic defrost system**

Refrigerators with this system melt away frost so you don't have to take everything out of your freezer to melt built-up ice.

## **Can caddy**

Holds and dispenses beverage cans to make accessing your favorite beverages quick and easy.

## **CEE Tier Standards**

Based on the Consortium for Energy Efficiency (CEE) qualifying product lists—with the Tier 3 standard being the most efficient.

## **Clear convertible compartment**

Helps preserve the freshness of meat and vegetables by allowing cool air from the freezer to enter the convertible compartment at the level you select.

## **Clear humidity controlled crisper**

Help preserve the freshness of your favorite fruits and vegetables with controlled humidity levels in the clear, extra-deep crisper.

## **Condiment Caddy**

Makes transferring condiments or other items from the refrigerator to the table or grill easy.

## **Counter depth configuration**

Fits virtually flush with the countertop, providing up to 6 inches of additional kitchen space while retaining the features and capacity you expect from a Whirlpool® refrigerator.

## **EasySlide bin**

Keep snacks close at hand with the industry-exclusive EasySlide bin. This snack compartment makes accessing everyday items easy with greater flexibility and sliding glass lids.

## **EasyView™ Triple Crisper system**

Increase your refrigerator's storage flexibility and keep fruits and vegetables tasting great with the EasyView™ Triple Crisper system. Now you can easily see and access produce with full crisper drawer visibility. Plus, organize a wide variety of items with three drawer options. Automatic humidity control also helps maintain freshness.

## **Electronic ice and water dispenser**

Dispenses filtered water on the outside of the refrigerator. A control lock feature prevents unintended operation. Select dispensers include an automatic LED night-light that adjusts brightness as the kitchen goes dark.

## **ENERGY STAR® qualification**

Exceeds government standards by over 20% to help conserve natural resources and save money on utility bills.

## **EZ Connect icemaker**

This optional icemaker makes adding easily accessible ice to select top-freezer refrigerators simple.

## **Fast Cool option**

Quickly lowers the refrigerator's temperature at the push of a button. Select Fast Cool after filling your refrigerator with groceries to quickly cool fresh food.

## **Fast Freeze**

Drops the freezer's temperature as low as it can go in the shortest amount of time. Activate Fast Freeze just before adding large amounts of unfrozen food.

## **Fast Ice**

Drops the freezer temperature in select models for a full 24 hours to increase ice production by over 30%.\*

## **Freezer divider**

Easily customizes freezer storage and organizes frozen food using the moveable freezer divider bin.

## **FreshFlow™ air filter**

This smart air filter is up to 15 times more effective than baking soda in reducing common food odors. Replace the filter every 6 months for optimal performance.

## **FreshFlow™ produce preserver**

Helps keep produce fresh longer.\*\* A cartridge absorbs ethylene gas that causes fruits and vegetables like lettuce and cantaloupe to over-ripen more quickly. Replace the filter every 6 months for optimal performance.

\*Compared to normal ice production, select models only. \*\*Based on commonly purchased produce.



# Glossary

## **FreshStor™ refrigerated drawer**

Put frequently used items in easy reach with a true refrigerated drawer. It features temperature controls that let you make adjustments based on which refrigerated items you'd like to store—from fresh produce to cold drinks. The full extension drawer and dividers also make it easy to organize and find what you need quickly.

## **In-Door-Ice® system**

This innovative system moves the ice bin to the door, creating room for an extra shelf in the refrigerator compartment. A removable, clear ice bin lets you fill coolers with ease.

## **In-Door-Ice® Plus system**

By placing the icemaker and removable ice bin in the door, this system creates 30% more usable space in the freezer.† The ice bin is also easily removed for portable ice any time.

## **LED interior lighting**

LED lighting puts a spotlight on food and casts a more natural light on the contents of your refrigerator so food looks as it should.

## **Measured Fill**

Allows you to select the exact amount of filtered water—in ounces, cups or liters—that you need. The dispenser will fill the container and automatically shut off when complete.

## **MicroEdge® spill-control shelf**

This industry-exclusive innovation gives you 25% more usable shelf space.†† Each shelf helps create wall-to-wall storage and makes cleaning inside the refrigerator easier than before.

## **No-slip door bin mat**

Keeps items stored in the door bins in an upright position. The mats are removable for easy cleaning.

## **Panoramic LED lighting**

Panoramic LED lighting makes finding items in your refrigerator easier by surrounding food with light. By placing lights throughout the refrigerator, shadows are reduced from every angle.

## **Pizza Pocket**

Easily stores frozen pizzas upright in select french door refrigerator's freezers, without the hassle of trying to fit them on flat freezer shelves.

## **PUR® water filtration system**

Reduces contaminants from household water, giving you chilled, filtered water from your refrigerator for up to 6 months. Our new PUR® water filtration system found on select models can save you up to \$600 a year instead of buying bottled water.‡

## **Satina™ finish**

Resists fingerprints for a smooth, glossy appearance, giving your kitchen a touch of style with everyday practicality. Accepts magnets and requires no special cleaners.

## **Satina™ Steel finish**

Available on select models, the Satina™ Steel finish provides a look that is even closer to true stainless steel. It cleans easily without special products, resists fingerprints and is magnetic.

## **SideKicks® upright models**

Place the refrigerator and freezer models side by side and get up to a combined 36 cu. ft. of storage for all your favorite foods. Both models feature gallon door bins and are ENERGY STAR® qualified.

## **SpillGuard™ glass shelf**

Helps contain spills and simplifies cleanup, preventing liquids from leaking onto shelves below. Some models feature shelves that are adjustable and slide out, providing easy access to items stored in the back of the refrigerator.

## **SpillMizer™ glass shelf**

Helps contain messy leaks and spills for easier cleanup. Shelves are both adjustable and transparent.

## **Tap Touch controls**

This innovative interface featured on select models brings high-tech style to your kitchen. It allows direct access to refrigerator functions, and its sleek appearance enhances the appeal of any space.

## **Temperature-controlled pantry**

A full-width temperature controlled pantry features a wide opening and holds large items like deli trays and sheet cakes.

## **Tilt-N-Go specialty bin**

Great for condiments or a carton of eggs, this specialty bin holds items securely and can be removed from the refrigerator door and placed on the table or counter.

## **Tri-freezer system**

Two upper sliding drawers and a spacious lower basket make organizing frozen food easy. Plus, easily customize freezer storage and organize frozen food with the moveable freezer divider bin.

## **Triple Crisper system**

Increases storage flexibility with two larger crispers with humidity controls and a center, smaller crisper.

†Compared to 26 cu. ft. Whirlpool® models with conventional icemakers. ††Compared to Whirlpool® side-by-side or french door models without MicroEdge® shelves. ‡Based on average use of two 6-month, 200-gallon water filters versus purchasing the same amount of a leading bottled water brand.



# French Door Refrigerators

## SPECIFICATIONS AND DIMENSIONS

| MODEL  | WHIRLPOOL®  |   |   |   | WHIRLPOOL GOLD®  |
|--|---|---|---|---|--|
|  | WRF560SFY   | WRF560SMY   | WRF560SEY   | WRF535SMB<br>WRF532SMB                      | GX5FHTXV   |
| <b>New 2013 model</b>                            |   |   |   |   |  |
| Capacity (cu. ft.)                               | 20  | 20  | 20  | 25<br>22                                    | 25   |
| Handle material                                  | Metal*  | Metal*  | Metal*  | Metal*                                      | Metal*   |
| Smooth door finish                               | -   | -   | -   | -   | -  |
| Designed, engineered and assembled in the U.S.A. | -   | -   | -   | ♦   | -  |
| <b>ICE &amp; WATER FEATURES</b>                  |   |   |   |   |  |
| Dispenser  |   |   | Exterior water  |   | Interior water   |
| PUR® 6-month ice and water filtration            |   | Ice only  | ♦   |   | ♦  |
| Water filter cartridge replacement               |   | <b>FILTER1 (W10295370)</b>                            | FILTER1 (W10295370)                                   |   | <b>FILTER4 (UKF8001)</b>   |
| Factory-installed icemaker                       | Optional (Part No. IC14B)                             | ♦   | -   | -   | -  |
| Dispenser control lock                           |   |   | ♦   |   |  |
| <b>PERFORMANCE FEATURES</b>                      |   |   |   |   |  |
| ENERGY STAR® qualified                           | -   | -   | -   | -   | -  |
| Meets CEE Tier standards**                       | Tier 2  | Tier 2  | Tier 2  |   | Tier 1   |
| Accu-Chill™ temperature management system        | -   | -   | -   | -   | -  |
| Adaptive Defrost                                 | -   | -   | -   | -   | -  |
| Temperature controls                             | Electronic  | Electronic  | Electronic  | Electronic                                  | Electronic   |
| FreshFlow™ produce preserver                     | -   | -   | -   | -   | -  |
| FreshFlow™ air filter                            | -   | -   | -   | -   | -  |
| Fast Cool option                                 | -   | -   | -   | -   | -  |
| Interior lighting                                | LED   | LED   | LED   | LED   | -  |
| <b>STORAGE FEATURES</b>                          |   |   |   |   |  |
| Refrigerator Compartment                         |   |   |   |   |  |
| Clear door bins                                  | 3 adjustable gallon, 2 fixed gallon, 1 fixed          | 3 adjustable gallon, 2 fixed gallon                   | 3 adjustable gallon, 2 fixed gallon                   | 2 adjustable gallon, 4 adjustable           | 1 adjustable gallon, 3 adjustable  |
| No-slip door bin mats                            |   |   |   |   | 2  |
| Glass shelves                                    |   |   |   | 4 half-width adjustable, 1 full-width fixed |  |
| SpillGuard™ glass shelves                        | 1 full-width slide-out adjustable, 1 full-width fixed | 1 full-width slide-out adjustable, 1 full-width fixed | 1 full-width slide-out adjustable, 1 full-width fixed |   | 3 half-width adjustable slide-out, 1 half-width adjustable, 1 full-width fixed |
| Adjustable fold-away glass shelf                 | SpillGuard™   | SpillGuard™   | SpillGuard™   |   |  |
| Clear humidity controlled crispers               | 2 split-width   | 2 split-width   | 2 split-width   | 2   | 2  |
| Full-width pantry                                | Temperature controlled                                | Temperature controlled                                | Temperature controlled                                | Temperature controlled                      | Temperature controlled   |
| Clear snack compartment                          |   |   |   |   | ♦  |
| Specialty door bin                               |   | Condiment Caddy                                       | Condiment Caddy                                       |   | Can caddy  |
| Clear dairy bin                                  |   |   |   |   | ♦  |
| Freezer Compartment                              |   |   |   |   |  |
| Upper slide-out basket                           | 1 white plastic                                       | 1 white plastic                                       | 1 white plastic                                       | 1 wire                                      | 1 wire   |
| Lower basket                                     | 1 white plastic                                       | 1 white plastic                                       | 1 white plastic                                       | 1 wire                                      | 1 wire   |
| Freezer light                                    | -   | -   | -   | -   | -  |
| <b>DIMENSIONS AND COLORS</b>                     |   |   |   |   |  |
| Height including hinges (A)                      | 68 1/2"   | 68 1/2"   | 68 1/2"   | 70 1/8"                                     | 69 3/8"  |
| Cabinet width (B)                                | 29 1/2"   | 29 1/2"   | 29 1/2"   | 35 1/4" / 32 1/4"                           | 35 1/8"  |
| Depth including handles (C)                      | 34 3/8"   | 34 3/8"   | 34 3/8"   | 35 1/2" / 34 1/2"                           | 35 1/2"  |
| Height excluding hinges                          | 67 1/2"   | 67 1/2"   | 67 1/2"   | 68 1/8"                                     | 68 3/4"  |
| Depth excluding handles                          | 32 3/8"   | 32 3/8"   | 32 3/8"   | 33" / 32"                                   | 32 29/32"  |
| Depth less door and base grille                  | 28 1/2"   | 28 1/2"   | 28 1/2"   | 29 1/8" / 28 1/8"                           | 29 1/8"  |
| Depth with door open 90°                         | 52 1/2"   | 52 1/2"   | 52 1/2"   | 48 1/8" / 47 1/8"                           | 48"  |
| Total volume (cu. ft.)                           | 19.6  | 19.6  | 19.6  | 24.8 / 21.7                                 | 24.8   |
| Refrigerator volume (cu. ft.)                    | 13.3  | 13.3  | 13.3  | 17.3 / 15.4                                 | 17.3   |
| Freezer volume (cu. ft.)                         | 6.3   | 6.3   | 6.3   | 7.5 / 6.3                                   | 7.5  |
| Total shelf area (sq. ft.)                       | 20.1  | 20.1  | 20.1  | 19.0 / 16.1                                 | 28.8   |
| Available colors                                 | W   B   M   | W   B   M   H   E                                     | W   B   M   | W   B   M                                   | G   B   Y  |

Bold type indicates a step-up feature

\*Monochromatic Satina™ Steel, Monochromatic Stainless Steel, White Ice and Black Ice models only.

\*\*Based on the Consortium for Energy Efficiency qualifying product lists. Visit [cae1.org](http://cae1.org) for more information.

DIMENSIONS ARE SHOWN FOR PLANNING PURPOSES ONLY.  
For complete information, see Installation Instructions packed with product.

# French Door Refrigerators

## SPECIFICATIONS AND DIMENSIONS

|   | WHIRLPOOL GOLD®   |                                |                              |   |  |
|---|---|--------------------------------|------------------------------|---|--|
| MODEL   | GI6FARXX  | WRF736SDA                      | WRF989SDA                    | WRX735SDB   | WRX988SIB                              |
| <b>New 2013 model</b>                               |   |                                |                              |   |  |
| Capacity (cu. ft.)                                  | <b>26</b>   | 26                             | <b>29</b>                    | 25  | <b>28</b>                              |
| Handle material                                     | Metal*  | Metal*                         | Metal*                       | Metal   | Metal*                                 |
| Smooth door finish                                  | -   | -                              | -                            | -   | -                                      |
| Designed, engineered and assembled in the U.S.A.    | -   | -                              | -                            | -   | -                                      |
| <b>ICE &amp; WATER FEATURES</b>                     |   |                                |                              |   |  |
| Exterior ice and water dispenser                    | ♦   | -                              | -                            | -   | -                                      |
| In-Door-Ice® system                                 | -   | ♦                              | -                            | -   | ♦                                      |
| Measured Fill                                       | -   | -                              | ♦                            | -   | -                                      |
| PUR® 6-month ice and water filtration               | -   | -                              | -                            | -   | -                                      |
| Water filter cartridge replacement                  | FILTER4 (UKF8001)   | FILTER2 (W10413645A)           | FILTER2 (W10413645A)         | FILTER4 (UKF8001)   | FILTER2 (W10413645A)                   |
| Factory-installed icemaker                          | -   | -                              | -                            | -   | -                                      |
| Fast Ice option                                     | -   | ♦                              | -                            | -   | ♦                                      |
| Crushed ice   | ♦   | -                              | -                            | -   | -                                      |
| Dispenser control lock                              | ♦   | -                              | -                            | -   | -                                      |
| <b>PERFORMANCE FEATURES</b>                         |   |                                |                              |   |  |
| ENERGY STAR® qualified                              | -   | -                              | -                            | -   | -                                      |
| Meets CEE Tier standards**                          | <b>Tier 2</b>   | Tier 2                         | Tier 2                       | Tier 1  | Tier 1                                 |
| Cooling system/technology                           | Accu-Chill™   | Accu-Chill™                    | <b>AccuFresh® dual</b>       | Accu-Chill™   | <b>AccuFresh® dual</b>                 |
| Adaptive Defrost                                    | -   | -                              | -                            | -   | -                                      |
| Temperature controls                                | <b>Tap Touch</b>  | Tap Touch                      | Tap Touch                    | Tap Touch   | Tap Touch                              |
| FreshFlow™ produce preserver                        | -   | ♦                              | -                            | -   | ♦                                      |
| FreshFlow™ air filter                               | -   | ♦                              | -                            | -   | ♦                                      |
| Fast Cool option                                    | ♦   | -                              | -                            | -   | ♦                                      |
| Interior lighting                                   | -   | <b>Panoramic LED</b>           | Panoramic LED                | LED   | <b>Panoramic LED</b>                   |
| <b>STORAGE FEATURES</b>                             |   |                                |                              |   |  |
| Refrigerator Compartment                            |   |                                |                              |   |  |
| Clear door bins                                     | <b>3 adjustable gallon, 3 fixed</b>   | 3 adjustable gallon, 3 fixed   | 3 adjustable gallon, 3 fixed | 3 adjustable gallon, 3 fixed  | 3 adjustable gallon, 1 fixed           |
| MicroEdge® glass shelves                            | -   | <b>3 half-width adjustable</b> | 3 half-width adjustable      | -   | 3 half-width adjustable                |
| SpillGuard™ glass shelves                           | <b>3 half-width adjustable slide-out, 1 mini adjustable, 1 full-width fixed</b> | 1 full-width fixed             | 1 full-width fixed           | 1 half-width adjustable slide-out, 2 half-width adjustable, 1 mini adjustable, 1 full-width fixed | 1 full-width fixed                     |
| Adjustable fold-away glass shelf                    | -   | <b>Half-width MicroEdge®</b>   | Half-width MicroEdge®        | -   | <b>Half-width MicroEdge®</b>           |
| Clear humidity controlled crispers                  | 2   | <b>Triple Crisper system</b>   | Triple Crisper system        | -   | <b>EasyView™ Triple Crisper system</b> |
| Temperature-controlled external refrigerated drawer | -   | -                              | -                            | ♦   | <b>FreshStor™</b>                      |
| Full-width pantry                                   | -   | <b>Temperature controlled</b>  | Temperature controlled       | -   | -                                      |
| Clear snack compartment                             | -   | -                              | -                            | 2   | <b>EasySlide bin</b>                   |
| Freezer Compartment                                 |   |                                |                              |   |  |
| Upper slide-out baskets                             | 1 wire  | <b>1 white plastic drawer</b>  | 1 white plastic drawer       | 1 wire drawer   | <b>2 white plastic drawers</b>         |
| Lower basket  | <b>1 white plastic</b>  | 1 white plastic                | 1 white plastic              | 1 white plastic   | 1 white plastic                        |
| Adjustable freezer divider                          | -   | ♦                              | -                            | -   | ♦                                      |
| Pizza Pocket  | -   | ♦                              | -                            | -   | ♦                                      |
| Freezer light                                       | -   | -                              | -                            | -   | -                                      |
| <b>DIMENSIONS AND COLORS</b>                        |   |                                |                              |   |  |
| Height including hinges (A)                         | 70 1/8"   | 70 1/8"                        | 70 1/8"                      | 70 1/8"   | 70 1/8"                                |
| Cabinet width (B)                                   | 35 3/8"   | 35 11/16"                      | 35 3/8"                      | 35 3/8"   | 35 3/8"                                |
| Depth including handles (C)                         | 35 1/4"   | 35 1/4"                        | 35 3/8"                      | 35 3/8"   | 35 11/16"                              |
| Height excluding hinges                             | 68 3/8"   | 68 3/8"                        | 68 3/8"                      | 68 3/8"   | 68 3/8"                                |
| Depth excluding handles                             | 32 1/8"   | 33 3/8"                        | 33 3/8"                      | 32 1/2"   | 33 3/8"                                |
| Depth less door and base grille                     | 29"   | 28 15/16"                      | 28 15/16"                    | 29"   | 28 15/16"                              |
| Depth with door open 90°                            | 48"   | 48"                            | 48"                          | 35 1/2"   | 48"                                    |
| Total volume (cu. ft.)                              | 25.5  | 26.1                           | 28.5                         | 25.0  | 28.1                                   |
| Refrigerator volume (cu. ft.)                       | 18.9  | 19.4                           | 20.8                         | 18.4  | 20.4                                   |
| Freezer volume (cu. ft.)                            | 6.6   | 6.8                            | 7.7                          | 6.6   | 7.7                                    |
| Total shelf area (sq. ft.)                          | 26.1  | 25.8                           | 27.0                         | 21.5  | 27.0                                   |
| Available colors                                    | Q   B   F   Y   | W   B   F   M                  | W   B   F   M   H   E        | M   | W   B   M   H   E                      |

Bold type indicates a step-up feature

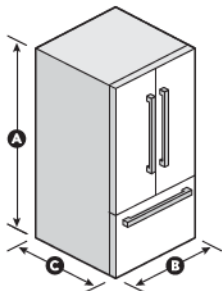

NOTE: Add 1/2" to each side for recessed installation.

**ELECTRICAL REQUIREMENTS:**  
115V, 60Hz. (Subject to local codes.)  
Listed by Underwriters' Laboratories, Inc.

\*Monochromatic Satina™ Steel, Monochromatic Stainless Steel, White Ice and Black Ice models only.  
\*\*Based on the Consortium for Energy Efficiency qualifying product lists. Visit [cae1.org](http://cae1.org) for more information.

DIMENSIONS ARE SHOWN FOR PLANNING PURPOSES ONLY.  
For complete information, see Installation Instructions packed with product.

# Counter Depth French Door Refrigerator

## SPECIFICATIONS AND DIMENSIONS

| WHIRLPOOL GOLD®                                  |  |
|--|--|
| <b>MODEL</b>                                     |  |
| Counter depth capacity (cu. ft.)                 | 20   |
| Handle material                                  | Metal  |
| Smooth door finish                               | -  |
| Designed, engineered and assembled in the U.S.A. | -  |
| <b>ICE &amp; WATER FEATURES</b>                  |  |
| Exterior ice and water dispenser                 | -  |
| PUR® 6-month ice and water filtration            | -  |
| Water filter cartridge replacement               | FILTER4 (UKF8001)  |
| Factory-installed icemaker                       | -  |
| Dispenser control lock                           | -  |
| <b>PERFORMANCE FEATURES</b>                      |  |
| ENERGY STAR® qualified                           | -  |
| Meets CEE Tier standards*                        | Tier 1   |
| Accu-Chill™ temperature management system        | -  |
| Adaptive Defrost                                 | -  |
| Temperature controls                             | Electronic   |
| Fast Cool option                                 | -  |
| <b>STORAGE FEATURES</b>                          |  |
| Refrigerator Compartment                         |  |
| Clear door bins                                  | 2 adjustable gallon, 2 adjustable, 2 mini fixed                          |
| No-slip door bin mats                            | 4  |
| SpillGuard™ glass shelves                        | 3 half-width adjustable slide-out, 1 mini adjustable, 1 full-width fixed |
| Clear humidity controlled crispers               | 2  |
| Full-width pantry                                | Temperature controlled   |
| Freezer Compartment                              |  |
| Upper slide-out baskets                          | 2 white plastic  |
| Lower basket                                     | 1 white plastic  |
| Freezer light                                    | -  |
| <b>DIMENSIONS AND COLORS</b>                     |  |
| Height including hinges (A)                      | 70 1/8"  |
| Cabinet width (B)                                | 35 5/8"  |
| Depth including handles (C)                      | 30 3/8"  |
| Height excluding hinges                          | 68 1/8"  |
| Depth excluding handles                          | 27 1/8"  |
| Depth less door and base grille                  | 24"  |
| Depth with door open 90°                         | 43"  |
| Total volume (cu. ft.)                           | 19.8   |
| Refrigerator volume (cu. ft.)                    | 14.9   |
| Freezer volume (cu. ft.)                         | 5.0  |
| Total shelf area (sq. ft.)                       | 20.9   |
| Available colors                                 | Y  |

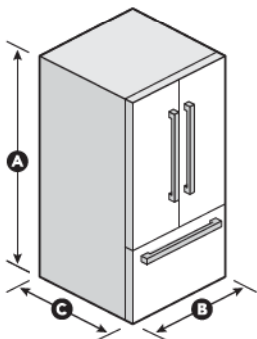

NOTE: Add 1/2" to each side for recessed installation.

**ELECTRICAL REQUIREMENTS:**

115V, 60Hz. (Subject to local codes.)  
Listed by Underwriters' Laboratories, Inc.

\*Based on the Consortium for Energy Efficiency qualifying product lists. Visit [cee1.org](http://cee1.org) for more information.

DIMENSIONS ARE SHOWN FOR PLANNING PURPOSES ONLY.  
For complete information, see Installation Instructions packed with product.

# Bottom-Freezer Refrigerators

## SPECIFICATIONS AND DIMENSIONS

| MODEL  | WHIRLPOOL®  | WHIRLPOOL GOLD®   |
|--|---|---|
|  | EB9SHKXV  | GB2FHDXW<br>GB9FHDXW  |
| Capacity (cu. ft.)                               | 19  | 22<br>19  |
| Refrigerator door style                          | Side-swing  | Side-swing  |
| Freezer door style                               | Side-swing  | <b>Drawer</b>   |
| Handle material                                  | Plastic   | <b>Metal**</b>  |
| Smooth door finish                               | -   | -   |
| Reversible doors                                 | 2   | 1   |
| Designed, engineered and assembled in the U.S.A. | -   | -   |
| <b>ICE &amp; WATER FEATURES</b>                  |   |   |
| Factory-installed icemaker                       | -   | -   |
| <b>PERFORMANCE FEATURES</b>                      |   |   |
| ENERGY STAR® qualified                           | -   | -   |
| Meets CEE Tier standards*                        | Tier 1  | <b>Tier 3</b>   |
| Accu-Chill™ temperature management system        | -   | -   |
| Adaptive Defrost                                 | -   | ♦   |
| Automatic defrost system                         | -   | -   |
| Electronic temperature controls                  | -   | -   |
| <b>STORAGE FEATURES</b>                          |   |   |
| Refrigerator Compartment                         |   |   |
| Door bins  | 5 white half-width adjustable, 1 white full-width fixed | <b>3 clear half-width adjustable, 1 white full-width fixed</b>                        |
| Glass shelves                                    | 2 full-width adjustable, 1 full-width fixed             | <b>3 half-width adjustable slide-out, 1 half-width adjustable, 1 full-width fixed</b> |
| Clear humidity controlled crispers               | 2   | 2   |
| Clear dairy bin                                  | -   | ♦   |
| Clear snack compartment                          | -   | ♦   |
| Freezer Compartment                              |   |   |
| Door bin   | 1 fixed   | -   |
| Wire shelf                                       | -   | -   |
| Upper slide-out wire basket                      | -   | ♦   |
| Lower wire basket                                | -   | -   |
| Freezer light                                    | -   | -   |
| <b>DIMENSIONS AND COLORS</b>                     |   |   |
| Height including hinges (A)                      | 66 7/8"   | 69 7/8" / 66 7/8"   |
| Cabinet width (B)                                | 29 1/2"   | 32 1/8" / 29 1/8"   |
| Depth including handles (C)                      | 33 1/2"   | 33 1/2"   |
| Height excluding hinges                          | 65 1/2"   | 65 1/2"   |
| Depth excluding handles                          | 30 7/8"   | 30 7/8"   |
| Depth less door and base grille                  | 28 1/8"   | 28 1/8"   |
| Depth with door open 90°                         | 59"   | 62" / 59"   |
| Total volume (cu. ft.)                           | 18.5  | 21.9 / 18.5   |
| Refrigerator volume (cu. ft.)                    | 12.9  | 15.6 / 12.9   |
| Freezer volume (cu. ft.)                         | 5.6   | 6.3 / 5.6   |
| Total shelf area (sq. ft.)                       | 20.0  | 23.5 / 20.0   |
| Available colors                                 | Q   | Q   B   S   |

Bold type indicates a step-up feature

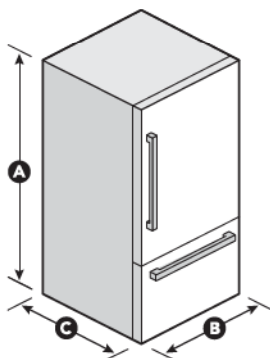

NOTE: Add 1/2" to each side for recessed installation.

ELECTRICAL REQUIREMENTS:  
115V, 60Hz. (Subject to local codes.)  
Listed by Underwriters' Laboratories, Inc.

\*Based on the Consortium for Energy Efficiency qualifying product lists. Visit [cee1.org](http://cee1.org) for more information.  
\*\*Stainless Steel model only.

DIMENSIONS ARE SHOWN FOR PLANNING PURPOSES ONLY.  
For complete information, see Installation Instructions packed with product.



# Side-by-Side Refrigerators

## SPECIFICATIONS AND DIMENSIONS

| MODEL                                     | WHIRLPOOL®  |   |   |   |   | WHIRLPOOL GOLD®   |
|---|---|---|---|---|---|---|
|   | WRS325FDA<br>WRS322FDA                              | WRS342FIA   | WSF26C2EX   | WRS526SIA   | WRS537SIA   | WRS950SIA   |
| <b>New 2013 model</b>                     | -   | -   | -   | -   | -   | -   |
| Capacity (cu. ft.)                        | 25<br>22  | 22  | 26  | 26  | 27  | 30  |
| Handle material                           | Metal*  | Metal*  | Metal*  | Metal   | Metal*  | Metal*  |
| Smooth door finish                        | -   | -   | -   | -   | -   | -   |
| Door styling                              | Flat  | Flat  | Flat  | Flat  | Contour   | Contour   |
| Hidden hinges                             | -   | -   | ♦   | -   | -   | -   |
| <b>WHIRLPOOL BRAND INNOVATIONS</b>        |   |   |   |   |   |   |
| Accu-Chill™ temperature management system | -   | -   | -   | -   | -   | -   |
| Adaptive Defrost                          | -   | -   | -   | -   | -   | -   |
| In-Door-Ice® system                       | -   | ♦   | Plus  | Plus  | Plus  | Plus  |
| FreshFlow™ air filter                     | -   | -   | AIR1 (W10311524)  | AIR1 (W10311524)  | AIR1 (W10311524)  | AIR1 (W10311524)  |
| <b>ICE &amp; WATER FEATURES</b>           |   |   |   |   |   |   |
| Exterior ice and water dispenser          | -   | -   | -   | -   | -   | -   |
| PUR® 6-month ice and water filtration     | -   | -   | -   | -   | -   | -   |
| Water filter cartridge replacement        | FILTER1 (W10295370A)                                | FILTER1 (W10295370A)                                | FILTER1 (W10295370A)  | FILTER1 (W10295370A)  | FILTER1 (W10295370A)  | FILTER1 (W10295370A)  |
| Factory-installed icemaker                | -   | -   | -   | -   | -   | -   |
| Fast Ice option                           | -   | -   | ♦   | -   | ♦   | -   |
| Water filter indicator light              | -   | -   | -   | -   | -   | -   |
| Control lock                              | -   | ♦   | -   | -   | -   | -   |
| LED dispenser night-light                 | -   | -   | ♦   | -   | -   | -   |
| Door alarm                                | -   | ♦   | -   | -   | -   | -   |
| <b>PERFORMANCE FEATURES</b>               |   |   |   |   |   |   |
| ENERGY STAR® qualified                    | -   | -   | -   | -   | -   | -   |
| Meets CEE Tier standards**                | Tier 2  | Tier 2  | Tier 1  | Tier 1  | Tier 3  | Tier 1  |
| Temperature controls                      | Up front interior LED                               | Exterior electronic LED                             | Exterior electronic   | Exterior electronic   | Tap Touch LED   | Tap Touch   |
| Interior lighting                         | -   | -   | -   | -   | -   | Panoramic LED   |
| <b>STORAGE FEATURES</b>                   |   |   |   |   |   |   |
| Refrigerator Compartment                  |   |   |   |   |   |   |
| Door storage                              | 3 clear adjustable gallon bins, 1 white fixed shelf | 3 clear adjustable gallon bins, 1 white fixed shelf | 3 clear adjustable gallon bins, 2 clear adjustable two-liter bins   | 2 clear adjustable gallon bins, 2 clear adjustable two-liter bins | 2 clear adjustable gallon bins, 2 clear adjustable two-liter bins | 2 clear adjustable gallon bins, 2 clear adjustable two-liter bins |
| Interior shelves                          | 2 adjustable glass, 1 fixed glass                   | 2 adjustable glass, 1 fixed glass                   | 2 adjustable slide-out SpillGuard™ glass, 1 fixed SpillGuard™ glass | 3 adjustable slide-out glass, 1 fixed glass                       | 3 adjustable slide-out glass, 1 fixed glass                       | 3 adjustable MicroEdge® glass, 1 fixed MicroEdge® glass           |
| Clear humidity controlled crisper         | -   | -   | -   | -   | -   | -   |
| Clear meat compartment                    | -   | -   | -   | -   | -   | -   |
| Clear convertible compartment             | -   | -   | -   | -   | -   | -   |
| Clear snack compartment                   | -   | -   | -   | -   | -   | -   |
| Clear dairy bin                           | -   | -   | -   | ♦   | -   | -   |
| Can caddy                                 | -   | ♦   | -   | -   | -   | -   |
| Freezer Compartment                       |   |   |   |   |   |   |
| Fixed door storage                        | 4 shelves   | 4 shelves   | 3 clear bins  | 3 clear bins  | 3 clear bins  | 3 clear bins  |
| Interior shelves                          | 3 wire  | 3 wire  | 3 glass   | 4 glass   | 4 glass   | 4 glass   |
| Lower storage                             | White basket  | White basket  | Clear basket  | Clear basket  | Clear basket  | 2 clear bins  |
| <b>DIMENSIONS AND COLORS</b>              |   |   |   |   |   |   |
| Height including hinges (A)               | 69 1/4" / 66 1/4"                                   | 66 1/4"   | 69 1/4"   | 69 1/4"   | 69 1/4"   | 69 1/4"   |
| Cabinet width (B)                         | 35 1/2" / 32 1/4"                                   | 32 1/4"   | 35 1/8"   | 35 1/8"   | 35 1/8"   | 35 1/8"   |
| Depth including handles (C)               | 34 3/8"   | 34 3/8"   | 34 1/8"   | 34 1/8"   | 36"   | 36"   |
| Height excluding hinges                   | 68 7/8" / 65 1/4"                                   | 65 1/4"   | 68 3/8"   | 68 3/8"   | 68 3/8"   | 68 3/8"   |
| Depth excluding handles                   | 32 1/4"   | 32 1/4"   | 32 3/8"   | 32 3/8"   | 33 1/2"   | 33 1/2"   |
| Depth less door and base grille           | 27 1/2"   | 27 1/2"   | 29 3/8"   | 29 3/8"   | 29 3/8"   | 29 3/8"   |
| Depth with door open 90°                  | 49 1/4"   | 49 1/4"   | 50 3/8"   | 50 3/8"   | 50 3/8"   | 50 3/8"   |
| Total volume (cu. ft.)                    | 25.4 / 22.0   | 22.0  | 26.4  | 26.4  | 26.5  | 29.7  |
| Refrigerator volume (cu. ft.)             | 15.4 / 14.6   | 14.6  | 16.4  | 16.4  | 16.6  | 17.5  |
| Freezer volume (cu. ft.)                  | 10.0 / 7.4  | 7.4   | 9.9   | 9.9   | 9.9   | 12.2  |
| Total shelf area (sq. ft.)                | 23.9 / 22.0   | 23.0  | 22.8  | 25.1  | 27.4  | 30.4  |
| Available colors                          | W   B   T   D   M                                   | W   B   M   | W   B   F   Y   | H   E   | W   B   F   M   | M   H   E   |

Bold type indicates a step-up feature

\*Monochromatic Satina™ Steel, Monochromatic Stainless Steel, White Ice and Black Ice models only.  
 \*\*Based on the Consortium for Energy Efficiency qualifying product lists. Visit [cae1.org](http://cae1.org) for more information.

DIMENSIONS ARE SHOWN FOR PLANNING PURPOSES ONLY.  
 For complete information, see Installation Instructions packed with product.

# Counter Depth Side-by-Side Refrigerators

## SPECIFICATIONS AND DIMENSIONS

| MODEL                                     | WHIRLPOOL®  |  | WHIRLPOOL GOLD®  |   |
|---|---|--|--|---|
|   | WRS321CDB   | GSC25C6EY  | WRS965CIA  |   |
| New 2013 model                            | -   | -  | -  | - |
| Capacity (cu. ft.)                        | 21  | 25   | 25   |   |
| Handle material                           | Metal   | Metal*   | Metal  |   |
| Smooth door finish                        | -   | -  | -  |   |
| Door styling                              | Flat  | Contour  | Contour  |   |
| Hidden hinges                             | -   | -  | -  |   |
| <b>WHIRLPOOL BRAND INNOVATIONS</b>        |   |  |  |   |
| Accu-Chill™ temperature management system | -   | -  | -  |   |
| Adaptive Defrost                          | -   | -  | -  |   |
| In-Door-Ice® system                       | -   | Plus   | Plus   |   |
| FreshFlow™ air filter                     | AIR1 (W10311524)  | AIR1 (W10311524)   | AIR1 (W10311524)   |   |
| <b>ICE &amp; WATER FEATURES</b>           |   |  |  |   |
| Exterior ice and water dispenser          | -   | -  | -  |   |
| PUR® 6-month ice and water filtration     | -   | -  | -  |   |
| Water filter cartridge replacement        | FILTER1 (W10295370A)                                    | FILTER1 (W10295370A)   | FILTER1 (W10295370A)   |   |
| Factory-installed icemaker                | -   | -  | -  |   |
| Water filter indicator light              | -   | -  | -  |   |
| Control lock                              | -   | -  | -  |   |
| LED dispenser night-light                 | -   | ◆  | -  |   |
| Door alarm                                | -   | -  | -  |   |
| <b>PERFORMANCE FEATURES</b>               |   |  |  |   |
| ENERGY STAR® qualified                    | -   | ◆  | -  |   |
| Meets CEE Tier standards**                | -   | Tier 1   | Tier 1   |   |
| Temperature controls                      | Exterior electronic                                     | Exterior electronic  | Tap Touch  |   |
| Interior lighting                         | -   | Panoramic LED  | Panoramic LED  |   |
| <b>STORAGE FEATURES</b>                   |   |  |  |   |
| <b>Refrigerator Compartment</b>           |   |  |  |   |
| Door bins                                 | 3 clear adjustable gallon, 2 clear adjustable two-liter | 2 clear adjustable gallon, 2 clear adjustable two-liter                | 4 clear adjustable gallon  |   |
| Interior shelves                          | 3 adjustable glass, 1 fixed glass                       | 3 adjustable <b>MicroEdge® glass</b> , 1 fixed <b>MicroEdge® glass</b> | 3 adjustable <b>MicroEdge® glass</b> , 1 fixed <b>MicroEdge® glass</b> |   |
| Clear humidity controlled crisper         | -   | -  | -  |   |
| Clear convertible compartment             | -   | -  | -  |   |
| Clear snack compartment                   | -   | -  | -  |   |
| Clear dairy bin                           | -   | ◆  | -  |   |
| Hanging beverage rack                     | -   | ◆  | -  |   |
| <b>Freezer Compartment</b>                |   |  |  |   |
| Fixed door storage                        | 3 clear bins  | 3 clear bins   | 3 clear bins   |   |
| Interior shelves                          | 4 glass   | 4 glass  | 4 glass  |   |
| Lower storage                             | Clear basket  | <b>2 clear bins</b>  | 2 clear bins   |   |
| <b>DIMENSIONS AND COLORS</b>              |   |  |  |   |
| Height including hinges (A)               | 68½"  | 72¼"   | 69¼"   |   |
| Cabinet width (B)                         | 35½"  | 35⅞"   | 35⅞"   |   |
| Depth including handles (C)               | 30"   | 30⅜"   | 30⅜"   |   |
| Height excluding hinges                   | 68½"  | 71"  | 68½"   |   |
| Depth excluding handles                   | 27½"  | 28⅞"   | 28⅞"   |   |
| Depth less door and base grille           | 24⅞"  | 24⅞"   | 24⅞"   |   |
| Depth with door open 90°                  | 45½"  | 45⅞"   | 45⅞"   |   |
| Total volume (cu. ft.)                    | 21.4  | 24.5   | 24.5   |   |
| Refrigerator volume (cu. ft.)             | 13.6  | 14.3   | 14.5   |   |
| Freezer volume (cu. ft.)                  | 7.9   | 10.2   | 10.0   |   |
| Total shelf area (sq. ft.)                | 17.8  | 22.5   | 23.3   |   |
| Available colors                          | M   | W   B   Y  | M   H   E  |   |

Bold type indicates a step-up feature

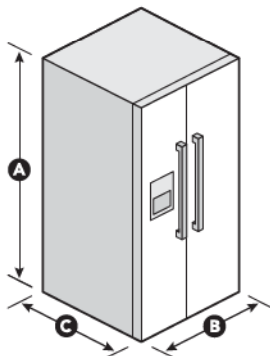

NOTE: Add 1/2" to each side for recessed installation.

ELECTRICAL REQUIREMENTS:  
115V, 60Hz. (Subject to local codes.)  
Listed by Underwriters' Laboratories, Inc.

\*Monochromatic Satina™ Steel, Monochromatic Stainless Steel, White Ice and Black Ice models only. \*\*Based on the Consortium for Energy Efficiency qualifying product lists. Visit [cee1.org](http://cee1.org) for more information.

DIMENSIONS ARE SHOWN FOR PLANNING PURPOSES ONLY.  
For complete information, see Installation Instructions packed with product.

# Flat Door Top-Freezer Refrigerators

## SPECIFICATIONS AND DIMENSIONS

| MODEL                           | WHIRLPOOL®   |  |  |   |  |   |
|---------------------------------|--|--|--|---|--|---|
|                                 | W4TXNFWF   | W6TXNFWF   | W5TXEWF  | W8TXNWF   | W8TXNWB  | W8TXNGZB  |
| <b>New 2013 model</b>           |  |  |  |   |  |   |
| Capacity (cu. ft.)              | 14   | 16   | 15   | 18  | 18   | 18  |
| Flat door style                 | -  | -  | -  | -   | -  | -   |
| Handle material                 | Plastic  | Plastic  | Plastic  | Plastic   | Plastic  | Plastic   |
| Handle type                     | Short  | Short  | Short  | Short   | Short  | Short   |
| Textured door finish            | -  | -  | -  | -   | -  | -   |
| ADA compliant*                  | -  | -  | ♦  | -   | -  | -   |
| <b>ICE &amp; WATER FEATURES</b> |  |  |  |   |  |   |
| Icemaker                        | Optional<br>(Part no. ECKMF94)                                       | Optional<br>(Part no. ECKMF94)                                       | Optional<br>(Part no. ECKMF94)                                       | Optional<br>(Part no. ECKMF94)  | <b>Factory-installed</b>   | Optional EZ Connect<br>(Part no. ECKMFEZ1)  |
| <b>PERFORMANCE FEATURES</b>     |  |  |  |   |  |   |
| ENERGY STAR® qualified          |  |  | ♦  |   |  |   |
| Meets CEE Tier standards**      |  |  | <b>Tier 1</b>  |   |  |   |
| Automatic defrost system        | -  | -  | -  | -   | -  | -   |
| Up-front temperature controls   | -  | -  | -  | -   | -  | -   |
| <b>STORAGE FEATURES</b>         |  |  |  |   |  |   |
| <b>Refrigerator Compartment</b> |  |  |  |   |  |   |
| Fixed door shelves              | 2 full-width,<br>1 partial-width                                     | 2 full-width,<br>1 partial-width                                     | 2 full-width,<br>1 partial-width                                     | 2 full-width,<br>1 partial-width  | 2 full-width,<br>1 partial-width                                     | 2 full-width,<br>1 partial-width  |
| Clear dairy bin                 | -  | -  | -  | -   | -  | -   |
| Interior shelves                | 2 full-width adjustable<br>wire, 1 full-width fixed<br>clear plastic | 2 full-width adjustable<br>wire, 1 full-width fixed<br>white plastic | 2 full-width adjustable<br>wire, 1 full-width fixed<br>white plastic | 2 full-width adjustable<br>wire, 1 full-width fixed<br><b>clear plastic</b> | 2 full-width adjustable<br>wire, 1 full-width fixed<br>clear plastic | 2 full-width adjustable<br><b>SpillMizer™ glass</b> ,<br>1 full-width fixed<br><b>SpillMizer™ glass</b> |
| Crispers                        | 2 white half-width   | 1 white full-width   | 1 white full-width   | <b>2 white half-width</b>   | 2 white half-width   | <b>2 clear half-width<br/>humidity controlled<br/>Sliding</b>   |
| Clear snack compartment         |  |  |  |   |  |   |
| <b>Freezer Compartment</b>      |  |  |  |   |  |   |
| Door shelves                    | 2 full-width   | 2 full-width   | 2 full-width   | 2 full-width  | 2 full-width   | 2 full-width  |
| Interior shelf                  | 1 half-width<br>adjustable wire                                      | 1 half-width<br>adjustable wire                                      | 1 half-width<br>adjustable wire                                      | 1 half-width<br>adjustable wire   | 1 half-width<br>removable wire                                       | <b>1 full-width adjustable<br/>SpillMizer™ glass</b>  |
| <b>DIMENSIONS AND COLORS</b>    |  |  |  |   |  |   |
| Height including hinges (A)     | 62 3/4"  | 65 1/4"  | 62 3/4"  | 67 1/8"   | 67 7/8"  | 67 7/8"   |
| Cabinet width (B)               | 28"  | 28"  | 28"  | 28"   | 28"  | 28"   |
| Depth including handles (C)     | 31 1/2"  | 32 3/8"  | 32 1/2"  | 32 3/8"   | 32 3/8"  | 32 3/8"   |
| Height excluding hinges         | 62 1/8"  | 65 1/8"  | 62 1/8"  | 67 1/8"   | 67 1/8"  | 67 1/8"   |
| Depth excluding handles         | 29 3/4"  | 30 3/8"  | 31 1/8"  | 30 3/8"   | 30 3/8"  | 30 3/8"   |
| Depth less door and base grille | 27 3/4"  | 27 3/8"  | 27 3/4"  | 27 3/8"   | 27 3/4"  | 27 3/4"   |
| Depth with door open 90°        | 57"  | 57"  | 57"  | 57"   | 57"  | 57"   |
| Total volume (cu. ft.)          | 14.4   | 15.9   | 14.6   | 17.6  | 17.6   | 17.6  |
| Refrigerator volume (cu. ft.)   | 10.6   | 12.0   | 10.8   | 13.5  | 13.5   | 13.5  |
| Freezer volume (cu. ft.)        | 3.8  | 3.9  | 3.8  | 4.1   | 4.1  | 4.1   |
| Total shelf area (sq. ft.)      | 17.1   | 18.5   | 16.5   | 19.1  | 19.1   | 19.1  |
| Available colors                | Q   T  | Q   T  | Q   B  | Q   B   T   | Q   B  | Q   B   T   |

Bold type indicates a step-up feature

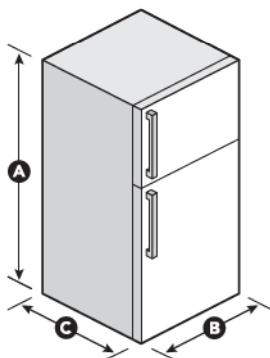

NOTE: Add 1/2" to each side for recessed installation.

ELECTRICAL REQUIREMENTS:  
115V, 60Hz. (Subject to local codes.)  
Listed by Underwriters' Laboratories, Inc.

\*Model meets applicable ADA requirements and must be installed in compliance with the current ADA Standards.  
\*\*Based on the Consortium for Energy Efficiency qualifying product lists. Visit [cee1.org](http://cee1.org) for more information.

DIMENSIONS ARE SHOWN FOR PLANNING PURPOSES ONLY.  
For complete information, see Installation Instructions packed with product.

# Flat Door Top-Freezer Refrigerators

## SPECIFICATIONS AND DIMENSIONS

| WHIRLPOOL®                      |  |  |   |   |
|---------------------------------|--|--|---|---|
| MODEL                           | W8TXEWFY   | W8TXEGFY   | WRT138TFY   | WRT311FZB   |
| <b>New 2013 model</b>           |  |  |   |   |
| Capacity (cu. ft.)              | 18   | 18   | 18  | 21  |
| Flat door style                 | -  | -  | -   | -   |
| Handle material                 | Plastic  | Plastic  | Plastic   | Metal   |
| Handle type                     | Short  | Short  | Short   | Short   |
| Textured door finish            | -  | -  | -   | -   |
| Door Reversal kit available     |  |  | W10395148   | W10395148   |
| ADA compliant*                  |  |  | ♦   | -   |
| <b>ICE &amp; WATER FEATURES</b> |  |  |   |   |
| Icemaker                        | Optional (Part no. ECKMF94)                                    | Optional (Part no. ECKMF94)  | Optional (Part no. ECKMF94)   | Optional EZ Connect (Part no. ECKMFEZ1)   |
| <b>PERFORMANCE FEATURES</b>     |  |  |   |   |
| ENERGY STAR® qualified          | ♦  | -  | -   | -   |
| Meets CEE Tier standards**      | <b>Tier 1</b>  | Tier 1   | Tier 1  | Tier 1  |
| Automatic defrost system        | -  | -  | -   | -   |
| Up-front temperature controls   | -  | -  | -   | -   |
| Interior lighting               |  |  | ♦   | -   |
| <b>STORAGE FEATURES</b>         |  |  |   |   |
| <b>Refrigerator Compartment</b> |  |  |   |   |
| White door bins                 |  |  |   | <b>3 partial-width adjustable</b>   |
| Fixed door shelves              | 2 full-width, 1 partial-width                                  | 2 full-width, 1 partial-width  | 2 full-width, 2 partial-width   | 1 partial-width, 1 full-width   |
| Interior shelves                | 2 full-width adjustable wire, 1 full-width fixed clear plastic | 2 full-width adjustable <b>SpillMizer™ glass</b> , 1 full-width fixed <b>SpillMizer™ glass</b> | 2 full-width adjustable SpillMizer™ glass, 1 full-width fixed SpillMizer™ glass | 2 full-width adjustable SpillMizer™ glass, 1 full-width fixed SpillMizer™ glass |
| Clear crispers                  | 2 half-width   | 2 half-width   | <b>2 split-width humidity controlled</b>  | 2 split-width humidity controlled   |
| Clear pantry                    |  |  | <b>Partial-width</b>  | <b>Full-width</b>   |
| Clear dairy bin                 | -  | -  | -   | -   |
| <b>Freezer Compartment</b>      |  |  |   |   |
| Door shelves                    | 2 full-width   | 2 full-width   | 2 full-width  | 2 full-width  |
| Interior shelf                  | 1 full-width adjustable wire                                   | 1 full-width adjustable wire   | 1 full-width removable wire   | 1 full-width removable <b>SpillMizer™ glass</b>                                 |
| <b>DIMENSIONS AND COLORS</b>    |  |  |   |   |
| Height including hinges (A)     | 67 1/8"  | 67 1/8"  | 66 1/4"   | 66 1/8"   |
| Cabinet width (B)               | 28"  | 28"  | 29 1/2"   | 32"   |
| Depth including handles (C)     | 32 1/4"  | 32 1/4"  | 32 1/4"   | 32"   |
| Height excluding hinges         | 67 3/8"  | 67 3/8"  | 65 1/2"   | 65 1/2"   |
| Depth excluding handles         | 30 1/4"  | 30 1/4"  | 30 3/4"   | 30 3/4"   |
| Depth less door and base grille | 27 1/4"  | 27 1/4"  | 28 1/2"   | 28 1/2"   |
| Depth with door open 90°        | 57"  | 57"  | 59 1/4"   | 62 1/8"   |
| Total volume (cu. ft.)          | 17.6   | 17.6   | 18.5  | 20.6  |
| Refrigerator volume (cu. ft.)   | 13.5   | 13.5   | 13.1  | 14.5  |
| Freezer volume (cu. ft.)        | 4.1  | 4.1  | 5.3   | 6.2   |
| Total shelf area (sq. ft.)      | 19.1   | 19.1   | 15.7  | 21.0  |
| Available colors                | Q   B  | Q   B  | W   B   S   | M   |

Bold type indicates a step-up feature

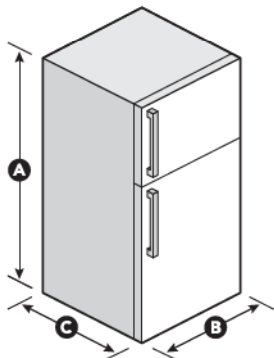

NOTE: Add 1/2" to each side for recessed installation.

ELECTRICAL REQUIREMENTS:  
115V, 60Hz. (Subject to local codes.)  
Listed by Underwriters' Laboratories, Inc.

\*Model meets applicable ADA requirements and must be installed in compliance with the current ADA Standards.  
\*\*Based on the Consortium for Energy Efficiency qualifying product lists. Visit [cae1.org](http://cae1.org) for more information.

DIMENSIONS ARE SHOWN FOR PLANNING PURPOSES ONLY.  
For complete information, see Installation Instructions packed with product.



# Contoured Door Top-Freezer Refrigerators

## SPECIFICATIONS AND DIMENSIONS

| MODEL                              | WHIRLPOOL®  |  |  |   |  |
|------------------------------------|---|--|--|---|--|
|                                    | WRT11SFA  | W6RXNGFW   | W8RXNGMB                                       | W8RXEGMW  | WRT311SFY  |
| <b>New 2013 model</b>              |   |  |  |   |  |
| Capacity (cu. ft.)                 | 11  | 16   | 18   | 18  | 21   |
| Contoured door style               | -   | -  | -  | -   | -  |
| Handle material                    |   |  |  |   | Plastic  |
| Handle type                        | Integrated  | Integrated   | Integrated                                     | Integrated  | <b>Contemporary</b>  |
| Door finish                        | Smooth  | Smooth   | Smooth   | Smooth  | Smooth   |
| Hidden hinges                      |   |  |  |   | ♦  |
| Door Reversal kit available        |   |  |  |   | <b>W10395148</b>   |
| ADA compliant*                     |   |  |  |   | ♦  |
| <b>ICE &amp; WATER FEATURES</b>    |   |  |  |   |  |
| Icemaker                           | Optional (Part no. 24ECKMF)   | Optional (Part no. ECKMF94)                          | <b>Factory-installed</b>                       | Factory-installed   | Optional (Part no. ECKMF94)                                    |
| <b>PERFORMANCE FEATURES</b>        |   |  |  |   |  |
| ENERGY STAR® qualified             |   |  |  | ♦   |  |
| Meets CEE Tier standards**         |   |  |  | <b>Tier 1</b>   |  |
| Temperature control system         | Up-front  | Up-front   | Up-front                                       | Up-front  | Up-front   |
| Automatic defrost system           | -   | -  | -  | -   | -  |
| Interior lighting                  | -   | -  | -  | -   | -  |
| <b>STORAGE FEATURES</b>            |   |  |  |   |  |
| Refrigerator Compartment           |   |  |  |   |  |
| Clear door bins                    | 1 full-width fixed,<br>1 full-width adjustable gallon,<br>1 full-width adjustable |  |  | <b>2 half-width adjustable gallon,<br/>1 half-width adjustable,<br/>1 full-width fixed gallon</b> | <b>2 Right Fit™ adjustable gallon,<br/>1 adjustable gallon</b> |
| Fixed door shelves                 |   | 2 full-width, 1 partial-width                        | 2 full-width, 1 partial-width                  | 1 full-width  | 1 full-width   |
| SpillMizer™ glass interior shelves | 2 full-width adjustable glass,<br>1 full-width fixed glass                        | 2 full-width adjustable,<br>1 full-width fixed       | 2 full-width adjustable,<br>1 full-width fixed | 2 full-width adjustable,<br>1 full-width fixed  | 2 full-width adjustable,<br>1 full-width fixed                 |
| Clear crispers                     | 1 full-width<br>humidity controlled   | <b>2 half-width<br/>humidity controlled</b>          | 2 half-width<br>humidity controlled            | 2 half-width<br>humidity controlled   | <b>2 split-width<br/>humidity controlled</b>                   |
| Partial-width pantry               |   |  |  |   | ♦  |
| Clear snack compartment            |   | <b>Sliding</b>                                       | Sliding  | Sliding   |  |
| Can caddy                          |   |  |  |   | ♦  |
| Clear dairy bin                    |   | ♦  | -  | -   | -  |
| Freezer Compartment                |   |  |  |   |  |
| Door shelves                       | 2 full-width  | 2 full-width   | 2 full-width                                   | 2 full-width  | 2 full-width   |
| Interior shelf                     | 1 half-width fixed wire   | <b>1 full-width adjustable<br/>SpillMizer™ glass</b> | 1 full-width removable<br>SpillMizer™ glass    | 1 full-width removable<br>SpillMizer™ glass   | 1 full-width removable wire                                    |
| <b>DIMENSIONS AND COLORS</b>       |   |  |  |   |  |
| Overall height (A)                 | 61½"  | 66"  | 68"  | 68"   | 66½"   |
| Cabinet width (B)                  | 24"   | 28"  | 28"  | 28"   | 32½"   |
| Depth including handles (C)        | 28½"  | 30½"   | 30½"   | 30½"  | 34"  |
| Cabinet height                     | 60¾"  | 65¾"   | 67¾"   | 67¾"  | 65½"   |
| Depth excluding handles            | 28¼"  | 30¼"   | 30¼"   | 30¼"  | 32¼"   |
| Depth less door and base grille    | 21½"  | 26½"   | 27½"   | 27½"  | 28½"   |
| Depth with door open 90°           | 48½"  | 55½"   | 54½"   | 54½"  | 62½"   |
| Total volume (cu. ft.)             | 10.7  | 15.9   | 17.5   | 17.5  | 20.6   |
| Refrigerator volume (cu. ft.)      | 7.8   | 12.0   | 13.5   | 13.5  | 15.0   |
| Freezer volume (cu. ft.)           | 2.9   | 3.9  | 4.1  | 4.1   | 6.1  |
| Total shelf area (sq. ft.)         | 11.9  | 18.5   | 18.7   | 18.7  | 21.0   |
| Available colors                   | W   B   F   | Q   B   S  | Q   B   D   S                                  | Q   B   D   S   | W   B   T  |

Bold type indicates a step-up feature

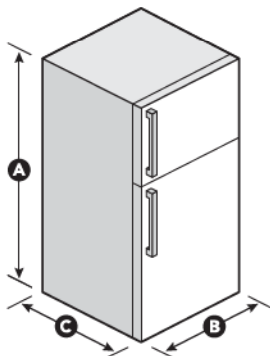

NOTE: Add 1/2" to each side for recessed installation.

ELECTRICAL REQUIREMENTS:  
115V, 60Hz. (Subject to local codes.)  
Listed by Underwriters' Laboratories, Inc.

\*Model meets applicable ADA requirements and must be installed in compliance with the current ADA Standards.  
\*\*Based on the Consortium for Energy Efficiency qualifying product lists. Visit [cee1.org](http://cee1.org) for more information.

DIMENSIONS ARE SHOWN FOR PLANNING PURPOSES ONLY.  
For complete information, see Installation Instructions packed with product.

# Contoured Door Top-Freezer Refrigerators

## SPECIFICATIONS AND DIMENSIONS

| MODEL                              | WHIRLPOOL®   |   | WHIRLPOOL GOLD®   |   |
|------------------------------------|--|---|---|---|
|                                    | WRT359SFY  | WRT371SZB   | WRT771RWY   | WRT771REY   |
| <b>New 2013 model</b>              |  |   |   |   |
| Capacity (cu. ft.)                 | 19   | 21  | 21  | 21  |
| Contoured door style               | -  | -   | -   | -   |
| Handle material                    | Plastic  | Plastic   | Plastic   | Plastic   |
| Handle type                        | Contemporary   | Contemporary  | <b>Embedded</b>   | Embedded  |
| Smooth door finish                 | -  | -   | -   | -   |
| Hidden hinges                      | -  | -   | -   | -   |
| Door Reversal kit available        | W10395148  | W10395148   | -   | -   |
| ADA compliant*                     | -  | -   | -   | -   |
| <b>ICE &amp; WATER FEATURES</b>    |  |   |   |   |
| Exterior water dispenser           | -  | -   | -   | ♦   |
| Interior water dispenser           | -  | -   | ♦   | -   |
| PUR® 6-month filtration            | -  | -   | ♦   | -   |
| Filter cartridge replacement       | -  | -   | <b>FILTER1 (W10295370)</b>                                      | FILTER1 (W10295370)   |
| Icemaker                           | Optional (Part no. ECKMF94)  | <b>Optional EZ Connect (Part no. ECKMFEZ1)</b>                  | <b>Factory-installed with clear ice bucket</b>                  | Factory-installed with clear ice bucket                         |
| Filter indicator light             | -  | -   | -   | -   |
| <b>PERFORMANCE FEATURES</b>        |  |   |   |   |
| ENERGY STAR® qualified             | ♦  | -   | -   | -   |
| Meets CEE Tier standards**         | <b>Tier 3</b>  | Tier 3  | Tier 3  | Tier 1  |
| Temperature controls               | Up-front   | Up-front  | Up-front <b>electronic Adaptive Defrost</b>                     | <b>Exterior electronic Adaptive Defrost</b>                     |
| Defrost system                     | Automatic  | Automatic   | <b>FRESH1 (W10346771A)</b>                                      | FRESH1 (W10346771A)   |
| FreshFlow™ produce preserver       | -  | -   | <b>AIR1 (W10311524)</b>   | AIR1 (W10311524)  |
| FreshFlow™ air filter              | -  | -   | -   | ♦   |
| Fast Cool option                   | -  | -   | -   | -   |
| Interior lighting                  | -  | <b>LED</b>  | -   | -   |
| <b>STORAGE FEATURES</b>            |  |   |   |   |
| Refrigerator Compartment           |  |   |   |   |
| Door bins                          | <b>2 Right Fit™ clear adjustable gallon, 1 clear adjustable gallon</b> | 2 Right Fit™ clear adjustable gallon, 1 clear adjustable gallon | 2 Right Fit™ clear adjustable gallon, 1 clear adjustable gallon | 2 Right Fit™ clear adjustable gallon, 1 clear adjustable gallon |
| Specialty door bin                 | Can caddy  | Can caddy   | <b>Tilt-N-Go</b>  | Tilt-N-Go   |
| Fixed door shelves                 | 1 full-width   | 1 full-width  | 1 full-width  | 1 full-width  |
| SpillMizer™ glass shelves          | 2 full-width adjustable, 1 full-width fixed                            | 2 full-width adjustable, 1 full-width fixed                     | 1 full-width adjustable, 1 full-width fixed                     | 1 full-width adjustable, 1 full-width fixed                     |
| Adjustable fold-away glass shelf   | -  | -   | ♦   | -   |
| Clear humidity controlled crispers | 2 split-width  | 2 split-width   | 2 split-width   | 2 split-width   |
| Full-width pantry                  | ♦  | -   | -   | -   |
| Clear dairy bin                    | -  | -   | -   | -   |
| Freezer Compartment                |  |   |   |   |
| Door shelves                       | 2 full-width   | 2 full-width  | 2 full-width  | 2 full-width  |
| Interior shelf                     | 1 full-width removable wire  | 1 full-width removable wire                                     | 1 full-width removable <b>SpillMizer™ glass</b>                 | 1 full-width removable SpillMizer™ glass                        |
| Freezer light                      | -  | <b>LED</b>  | -   | -   |
| <b>DIMENSIONS AND COLORS</b>       |  |   |   |   |
| Overall height (A)                 | 66 1/8"  | 66 7/8"   | 66 1/8"   | 66 1/8"   |
| Cabinet width (B)                  | 29 1/2"  | 32 1/2"   | 32 1/2"   | 32 1/2"   |
| Depth including handles (C)        | 34"  | 34"   | 34"   | 32 1/8"   |
| Cabinet height                     | 65 1/2"  | 65 1/2"   | 65 1/2"   | 65 1/2"   |
| Depth excluding handles            | 32 1/8"  | 32 1/2"   | 34"   | 32 1/8"   |
| Depth less door and base grille    | 28 1/2"  | 28 1/2"   | 28 1/2"   | 28 1/2"   |
| Depth with door open 90°           | 59 1/8"  | 62 1/8"   | 62 1/8"   | 62 1/8"   |
| Total volume (cu. ft.)             | 18.9   | 21.1  | 21.1  | 21.1  |
| Refrigerator volume (cu. ft.)      | 13.6   | 15.0  | 15.0  | 15.0  |
| Freezer volume (cu. ft.)           | 5.3  | 6.1   | 6.1   | 6.1   |
| Total shelf area (sq. ft.)         | 18.0   | 20.2  | 20.2  | 20.2  |
| Available colors                   | W   B   F   M  | W   B   F   M   | W   B   M   | W   B   M   |

Bold type indicates a step-up feature

\*Model meets applicable ADA requirements and must be installed in compliance with the current ADA Standards. \*\*Based on the Consortium for Energy Efficiency qualifying product lists. Visit [cee1.org](http://cee1.org) for more information.

DIMENSIONS ARE SHOWN FOR PLANNING PURPOSES ONLY.  
For complete information, see Installation Instructions packed with product.

# Upright Freezers

## SPECIFICATIONS AND DIMENSIONS

| MODEL  | WHIRLPOOL®                       |                                  |                                  |                                  |                                  |                                  |  |
|--|----------------------------------|----------------------------------|----------------------------------|----------------------------------|----------------------------------|----------------------------------|--|
|  | EV160FXB                         | EV160NZT                         | EV161NZT                         | EV180NZB                         | EV200FXB                         | EV200NZB                         | EV201NZT                                       |
| <b>New 2013 model</b>                            | -                                | -                                | -                                | -                                | -                                | -                                | -  |
| Capacity (cu. ft.)                               | 16                               | 16                               | 16                               | <b>18</b>                        | <b>20</b>                        | 20                               | 20   |
| Contoured door style                             | -                                | -                                | -                                | -                                | -                                | -                                | -  |
| Door finish                                      | Textured                         | Textured                         | <b>Smooth</b>                    | Textured                         | Textured                         | Textured                         | <b>Smooth</b>                                  |
| Reversible door                                  | -                                | ♦                                | -                                | -                                | -                                | ♦                                | -  |
| Designed, engineered and assembled in the U.S.A. | -                                | -                                | -                                | -                                | -                                | -                                | -  |
| <b>PERFORMANCE FEATURES</b>                      |                                  |                                  |                                  |                                  |                                  |                                  |  |
| ENERGY STAR® qualified                           | -                                | -                                | -                                | -                                | -                                | -                                | -  |
| Frost-free defrost                               | -                                | ♦                                | -                                | -                                | -                                | ♦                                | -  |
| Fast Freeze                                      | -                                | -                                | -                                | -                                | -                                | -                                | -  |
| Temperature alarm                                | -                                | -                                | ♦                                | -                                | -                                | -                                | ♦  |
| Interior light                                   | -                                | -                                | -                                | -                                | -                                | -                                | -  |
| <b>STORAGE FEATURES</b>                          |                                  |                                  |                                  |                                  |                                  |                                  |  |
| Door storage                                     | 5 fixed shelves                  | 5 fixed shelves                  | 5 fixed shelves                  | <b>6 fixed shelves</b>           | 6 fixed shelves                  | 6 fixed shelves                  | <b>6 adjustable bins, 1 fixed gallon shelf</b> |
| Mid-level storage                                | -                                | -                                | -                                | -                                | -                                | -                                | <b>1 wire basket</b>                           |
| Lower storage                                    | 1 flip-down wire gate            | 1 flip-down wire gate            | <b>1 wire basket</b>             | 1 flip-down wire gate            | 1 flip-down wire gate            | 1 flip-down wire gate            | <b>1 wire basket</b>                           |
| Wire shelves                                     | 3 fixed                          | <b>3 removable</b>               | 3 removable                      | <b>3 adjustable</b>              | 4 fixed                          | <b>4 adjustable</b>              | 4 adjustable                                   |
| <b>DIMENSIONS AND COLORS</b>                     |                                  |                                  |                                  |                                  |                                  |                                  |  |
| Height including hinges (A)                      | 61 <sup>1</sup> / <sub>8</sub> " | 61 <sup>1</sup> / <sub>4</sub> " | 61 <sup>1</sup> / <sub>4</sub> " | 67 <sup>5</sup> / <sub>8</sub> " | 67 <sup>1</sup> / <sub>4</sub> " | 67 <sup>1</sup> / <sub>4</sub> " | 67 <sup>1</sup> / <sub>4</sub> "               |
| Cabinet width (B)                                | 32"                              | 32"                              | 30"                              | 30"                              | 33"                              | 33"                              | 33"  |
| Depth including handles (C)                      | 30 <sup>1</sup> / <sub>4</sub> " | 31 <sup>1</sup> / <sub>4</sub> " | 31 <sup>1</sup> / <sub>4</sub> " | 31 <sup>5</sup> / <sub>8</sub> " | 30 <sup>1</sup> / <sub>4</sub> " | 30 <sup>1</sup> / <sub>4</sub> " | 31 <sup>1</sup> / <sub>4</sub> "               |
| Height excluding hinges                          | 60"                              | 60"                              | 60"                              | 66"                              | 66"                              | 66"                              | 66"  |
| Depth excluding handles                          | 30 <sup>1</sup> / <sub>4</sub> " | 30 <sup>1</sup> / <sub>4</sub> " | 30 <sup>1</sup> / <sub>4</sub> " | 30 <sup>1</sup> / <sub>4</sub> " | 30 <sup>1</sup> / <sub>4</sub> " | 30 <sup>1</sup> / <sub>4</sub> " | 30 <sup>1</sup> / <sub>4</sub> "               |
| Depth excluding door                             | 25 <sup>1</sup> / <sub>2</sub> " | 25 <sup>1</sup> / <sub>2</sub> " | 25 <sup>1</sup> / <sub>2</sub> " | 25 <sup>1</sup> / <sub>2</sub> " | 25 <sup>1</sup> / <sub>2</sub> " | 25 <sup>1</sup> / <sub>2</sub> " | 25 <sup>1</sup> / <sub>2</sub> "               |
| Depth with door open 90°                         | 56 <sup>5</sup> / <sub>8</sub> " | 56 <sup>5</sup> / <sub>8</sub> " | 56 <sup>5</sup> / <sub>8</sub> " | 56 <sup>5</sup> / <sub>8</sub> " | 59 <sup>5</sup> / <sub>8</sub> " | 59 <sup>5</sup> / <sub>8</sub> " | 59 <sup>5</sup> / <sub>8</sub> "               |
| Total volume (cu. ft.)                           | 16.0                             | 15.8                             | 15.8                             | 17.7                             | 20.1                             | 20.1                             | 20.1   |
| Shipping weight                                  | 170 lbs                          | 178 lbs                          | 176 lbs                          | 185 lbs                          | 211 lbs                          | 205 lbs                          | 211 lbs  |
| Available colors                                 | Q                                | Q                                | Q                                | Q                                | Q                                | Q                                | Q  |

Bold type indicates a step-up feature

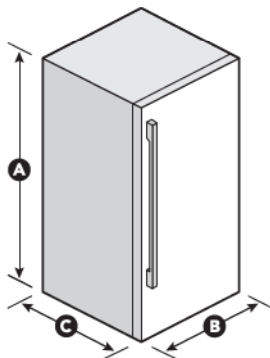

NOTE: Add 1/2" to each side for recessed installation.

ELECTRICAL REQUIREMENTS:  
115V, 60Hz. (Subject to local codes.)  
Listed by Underwriters' Laboratories, Inc.

DIMENSIONS ARE SHOWN FOR PLANNING PURPOSES ONLY.  
For complete information, see Installation Instructions packed with product.

# Chest Freezers

## SPECIFICATIONS AND DIMENSIONS

| MODEL  | WHIRLPOOL® |          |           |           |
|--|------------|----------|-----------|-----------|
|  | EH151FXT   | EH155FXB | EH185FXT  | EH225FXT  |
| <b>New 2013 model</b>                            |            |          |           |           |
| Capacity (cu. ft.)                               | 15         | 15       | <b>18</b> | <b>22</b> |
| Flat textured lid                                | -          | -        | -         | -         |
| Integrated door handle design                    | -          | -        | -         | -         |
| 1-Year limited warranty                          | -          | -        | -         | -         |
| Designed, engineered and assembled in the U.S.A. | -          | -        | -         | -         |
| <b>PERFORMANCE FEATURES</b>                      |            |          |           |           |
| ENERGY STAR® qualified                           | -          | -        | -         | -         |
| Defrost drain with hose adapter                  | -          | -        | -         | -         |
| Mechanical controls                              | -          | -        | -         | -         |
| Adjustable thermostat                            | -          | -        | -         | -         |
| Temperature alarm                                | -          | ♦        | -         | -         |
| Power On light                                   | -          | ♦        | -         | -         |
| Interior light                                   | -          | ♦        | -         | -         |
| 5-sided freezer coils                            | -          | -        | -         | -         |
| <b>STORAGE FEATURES</b>                          |            |          |           |           |
| Solid core lid                                   | -          | -        | -         | -         |
| Lid lock with key                                | -          | -        | -         | -         |
| Large storage baskets                            | 2          | 2        | <b>3</b>  | <b>3</b>  |
| Rounded interior corners                         | -          | -        | -         | -         |
| Dishpan bottom                                   | -          | ♦        | -         | -         |
| 75° Door stops                                   | -          | -        | ♦         | -         |
| <b>DIMENSIONS AND COLORS</b>                     |            |          |           |           |
| Height (A)                                       | 34 1/4"    | 34 1/4"  | 34 1/4"   | 34 1/4"   |
| Width (B)  | 46 1/8"    | 46 1/8"  | 54"       | 64 5/8"   |
| Depth without handle (C)                         | 28 1/2"    | 29 1/2"  | 28 1/2"   | 28 1/2"   |
| Height with lid open 90°                         | 60 1/8"    | 60 1/8"  | 60 1/8"   | 60 1/8"   |
| Carton width                                     | 48 1/2"    | 48 1/2"  | 56 1/2"   | 67 1/2"   |
| Carton depth                                     | 30 1/2"    | 30 1/2"  | 30 1/2"   | 30 1/2"   |
| Total volume (cu. ft.)                           | 14.8       | 14.8     | 17.5      | 21.7      |
| Available colors                                 | Q          | Q        | Q         | Q         |

Bold type indicates a step-up feature

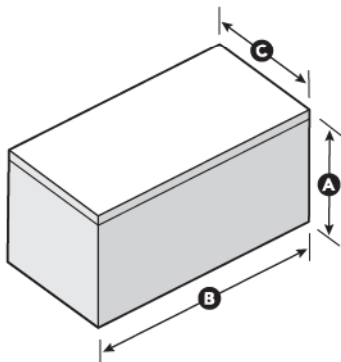

NOTE: Add 1/2" to each side for recessed installation.

ELECTRICAL REQUIREMENTS:  
115V, 60Hz. (Subject to local codes.)  
Listed by Underwriters' Laboratories, Inc.

DIMENSIONS ARE SHOWN FOR PLANNING PURPOSES ONLY.  
For complete information, see Installation Instructions packed with product.



# SideKicks® Upright Freezer & Refrigerator

## SPECIFICATIONS AND DIMENSIONS

| WHIRLPOOL®                                       |                         |                                      |  |
|--|-------------------------|--------------------------------------|--|
| MODEL  | EV188NYW<br>All Freezer | EL88TRRW<br>All Refrigerator         |  |
| Capacity (cu. ft.)                               | 18                      | 18                                   |  |
| Flat door style                                  | -                       | -                                    |  |
| Smooth door finish                               | -                       | -                                    |  |
| Handle material                                  | Metal                   | Metal                                |  |
| Designed, engineered and assembled in the U.S.A. | -                       | -                                    |  |
| <b>PERFORMANCE FEATURES</b>                      |                         |                                      |  |
| ENERGY STAR® qualified                           | -                       | -                                    |  |
| Meets CEE Tier standards*                        | Tier 1                  | Tier 1                               |  |
| Frost-free defrost                               | -                       | -                                    |  |
| Icemaker ready                                   | ECKMF94                 | -                                    |  |
| Interior light                                   | -                       | -                                    |  |
| Installation wheels                              | -                       | -                                    |  |
| <b>STORAGE FEATURES</b>                          |                         |                                      |  |
| Gallon door bins                                 | 6                       | 6                                    |  |
| Fixed gallon door shelf                          | -                       | -                                    |  |
| Clear dairy door bins                            | -                       | 2                                    |  |
| Mid-level storage                                | 1 wire basket           | 1 meat compartment                   |  |
| Lower storage                                    | 1 wire basket           | 2 clear humidity controlled crispers |  |
| Adjustable shelves                               | 4 glass                 | 4 glass                              |  |
| <b>DIMENSIONS AND COLORS</b>                     |                         |                                      |  |
| Height including hinges (A)                      | 66 1/2"                 | 66 1/2"                              |  |
| Cabinet width (B)                                | 30"                     | 30"                                  |  |
| Depth including handles (C)                      | 31"                     | 31"                                  |  |
| Height excluding hinges                          | 66"                     | 66"                                  |  |
| Depth excluding handles                          | 28 1/2"                 | 28 1/2"                              |  |
| Depth excluding door                             | 25 1/2"                 | 24 1/2"                              |  |
| Depth with door open 90°                         | 56 1/4"                 | 56 1/4"                              |  |
| Total volume (cu. ft.)                           | 17.7                    | 17.7                                 |  |
| Shipping weight                                  | 186 lbs                 | 186 lbs                              |  |
| Available colors                                 | Q   S                   | Q   S                                |  |

# SideKicks® Upright Freezer & Refrigerator Trim Kits

## SPECIFICATIONS

|  | PART NUMBER |
|--|-------------|
| Stainless Steel Trim Kit (18 cu. ft.)      | SKT60S      |
| Stainless Steel Finishing Kit (18 cu. ft.) | SKFK60S     |

### Stainless Steel Trim Kit #SKT60S

1. Top trim extrusion (1)
2. Grill extrusion (6)
3. Notched grille extrusion (1)
4. Right extrusion side trim (1)
5. Left extrusion side trim (1)
6. Styrofoam spacer (1)
7. Grille bottom assembly (1)
8. Front bracket (1), Screws (4)
9. Gap filler assembly, Assorted screws

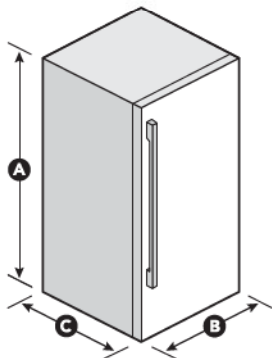

NOTE: Add 1/2" to each side for recessed installation.

ELECTRICAL REQUIREMENTS:  
115V, 60Hz. (Subject to local codes.)  
Listed by Underwriters' Laboratories, Inc.

### Stainless Steel Finishing Kit #SKFK60S

6. Styrofoam spacer (1)
7. Grille bottom assembly (1)
8. Front bracket (1), Screws (4)
9. Gap filler assembly, Assorted screws

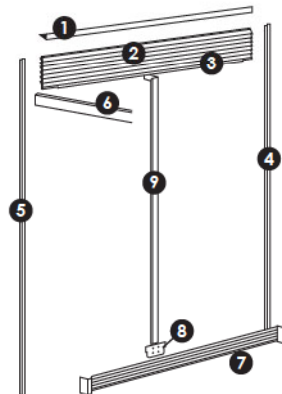

\*Based on the Consortium for Energy Efficiency qualifying product lists. Visit [cee1.org](http://cee1.org) for more information.

DIMENSIONS ARE SHOWN FOR PLANNING PURPOSES ONLY.  
For complete information, see Installation Instructions packed with product.

# Automatic Icemaker

## SPECIFICATIONS AND DIMENSIONS

| WHIRLPOOL GOLD®                                  |   |
|--|---|
| <b>MODEL</b>                                     | <b>G115NDXZ</b>                           |
| New 2013 model                                   | -   |
| Storage space                                    | Up to 25 lbs                              |
| Ice production per day                           | Up to 50 lbs                              |
| Flat door style                                  | -   |
| Door swing                                       | Reversible                                |
| Handle style                                     | Lip                                       |
| Designed, engineered and assembled in the U.S.A. | -   |
| <b>PERFORMANCE FEATURES</b>                      |   |
| PUR® 6-month ice filtration                      | -   |
| Filter cartridge replacement                     | ICE2 (F2WC911)                            |
| Fast ice   | -   |
| Service indicator                                | -   |
| Electronic Clean cycle                           | -   |
| Interior light                                   | -   |
| Ice scoop  | -   |
| <b>OPTIONAL ACCESSORIES</b>                      |   |
| Self-install internal drain pump                 | 1901                                      |
| Trim kit   | Q - 8171343<br>B - 8171345<br>S - 8171347 |
| Icemaker cleaner                                 | 4396808                                   |
| <b>DIMENSIONS AND COLORS</b>                     |   |
| Height (A)                                       | 33 7/8"–34 1/8"                           |
| Width (B)  | 14 1/8"                                   |
| Depth including handles (C)                      | 25 1/8"                                   |
| Depth excluding handles (D)                      | 23 1/4"                                   |
| Available colors                                 | Q   B   S                                 |

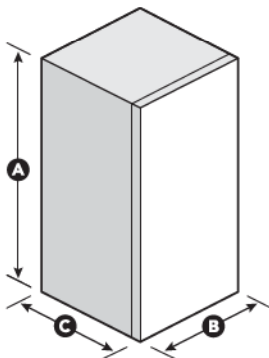

NOTE: Add 1/2" to each side for recessed installation.

**ELECTRICAL REQUIREMENTS:**  
115V, 60Hz. (Subject to local codes.)  
Listed by Underwriters' Laboratories, Inc.

Whirlpool brand is constantly improving and innovating our products, so the specifications and dimensions in this catalog are subject to change without notice.





## COOKING

- 72 Freestanding ranges
- 92 Wall ovens
- 100 Cooktops
- 114 Microwaves
- 122 Hoods and vents
- 132 Accessories
- 134 Glossary
- 138 Specifications





## FREESTANDING RANGES



### Boils 6 liters of water in 50% less time\*

Select ranges feature a cooktop with AccuHeat™ induction technology. It lets you cook with less time, less energy and more precision.\*\* This advanced technology offers easier cleaning and efficient cooking by transferring energy directly into any cookware with magnetic bases.



### Bakes evenly and seals in flavors on every rack

The AccuBake® temperature management system monitors oven temperature and controls the cooking elements, delivering consistent results every time. Our most advanced models feature TimeSavor™ Plus true convection that uses a rear fan and a third heating element to seal in flavors and juices on every rack.



### Innovative oven cleaning

AquaLift® self-clean technology, available on single cavity freestanding ranges, offers easy and odor-free oven cleaning in only 50 minutes.† As our most energy-efficient self-cleaning cycle available,†† it releases baked-on foods from an innovative coating throughout the oven without harsh chemicals.



### More room with a view

Check on cooking progress without opening the door with the EasyView™ extra-large oven window, the industry's largest window available.‡

NOTE: Not all features are available on all models.

\*Based on boiling 6 liters of water with 11" 3,700-watt induction element versus 12,500-BTU gas burner. \*\*Compared to conventional electric radiant cooktops. †Based on average cleaning time of self-clean cycle with water and moderate soils. ††Versus traditional self clean cycle. ‡Based on interior viewable window of leading brand freestanding ranges.

## Freestanding Double Oven Electric Ranges

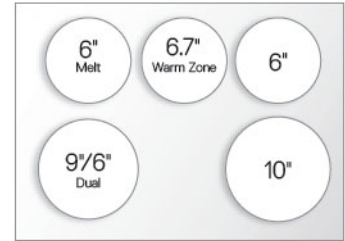

### WGE555S0B 6.7 total cu. ft. W | B | S

Eco-friendly ceramic glass cooktop\*

#### LOWER OVEN

EasyView™ extra-large oven window

#### BOTH OVENS

Precise Clean™ self-cleaning system

AccuBake® temperature management system



### WGE755C0B 6.7 total cu. ft. S | H | E

Whirlpool Gold® model

Eco-friendly ceramic glass cooktop\*

#### LOWER OVEN

TimeSaver™ Plus true convection

EasyView™ extra-large oven window

#### BOTH OVENS

SteamClean option

Hidden bake element

Precise Clean™ self-cleaning system

AccuBake® temperature management system

\*Glass cooktop surface manufactured without the release of hazardous metals into the earth.

Step-up features  
highlighted by  
yellow bar

## Freestanding Double Oven Electric Ranges



### **WGI925C0B 6.7 total cu. ft. Induction Range S**

Whirlpool Gold® model

AccuHeat™ induction technology

Ceramic glass cooktop

#### **LOWER OVEN**

TimeSaver™ convection

EasyView™ extra-large oven window

#### **BOTH OVENS**

Precise Clean™ self-cleaning system

SteamClean option

Hidden bake element

AccuBake® temperature management system

Feature descriptions can be found in the glossary on pages 134–137. Complete product specifications can be found on page 138.



## Freestanding Double Oven Gas Ranges



|                      |       |
|----------------------|-------|
| 5,000<br>AccuSimmer® | 9,200 |
| 15,000<br>Power™     | 9,200 |

### **WGG555S0B 6.0 total cu. ft. W | B | S**

Full-width, satin-finish cast-iron grates  
15,000-BTU Power™ burner  
5,000-BTU AccuSimmer® burner

### **LOWER OVEN**

EasyView™ extra-large oven window

### **BOTH OVENS**

Precise Clean™ self-cleaning system  
Hidden bake element  
AccuBake® temperature management system

Step-up features  
highlighted by  
yellow bar

## Freestanding Double Oven Gas Ranges

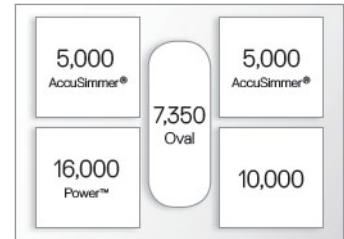

### **WGG755S0B 6.0 total cu. ft. S | H | E**

Whirlpool Gold® model

16,000-BTU Power™ burner

Multiple 5,000-BTU AccuSimmer® burners

7,350-BTU Oval burner

Full-width, satin-finish cast-iron grates

### **LOWER OVEN**

TimeSavor™ convection

EasyView™ extra-large oven window

### **BOTH OVENS**

Precise Clean™ self-cleaning system

Hidden bake element

AccuBake® temperature management system

NOTE: Cooktop BTUs are listed for each model.

Feature descriptions can be found in the glossary on pages 134–137. Complete product specifications can be found on page 139.

## Freestanding Electric Ranges

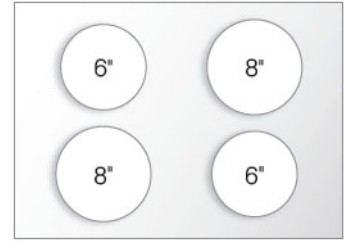

### **WFC130M0A 4.8 cu. ft. W | B**

- Standard oven window
- Upswept porcelain SpillGuard™ cooktop
- Storage drawer



### **WFC340S0A 4.8 cu. ft. W | B | S**

- Traditional self-cleaning system
- Large oven window
- ADA compliant\*
- Upswept porcelain SpillGuard™ cooktop
- Storage drawer

\*Model meets applicable ADA requirements and must be installed in compliance with the current ADA Standards.

Step-up features  
highlighted by  
yellow bar

## Freestanding Electric Ranges

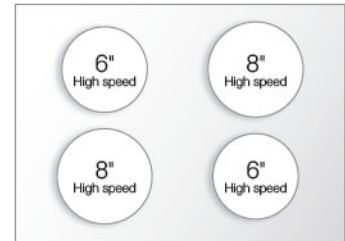

### WFC310S0A 4.8 cu. ft. W | B | S

- AccuBake® temperature management system
- Traditional self-cleaning system
- Large oven window
- Upswept porcelain SpillGuard™ cooktop
- Storage drawer

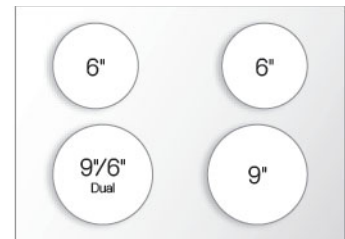

### WFE320M0A 4.8 cu. ft. W | B | S

- Eco-friendly ceramic glass cooktop\*\*
- Large oven window
- Storage drawer

\*\*Glass cooktop surface manufactured without the release of hazardous metals into the earth.

Feature descriptions can be found in the glossary on pages 134–137. Complete product specifications can be found on page 140.



## Freestanding Electric Ranges

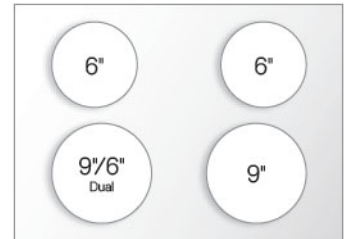

### WFE510S0A 4.8 cu. ft. W | B | T | D | S

- AccuBake® temperature management system
- Traditional self-cleaning system
- Large oven window
- Eco-friendly ceramic glass cooktop\*
- Storage drawer

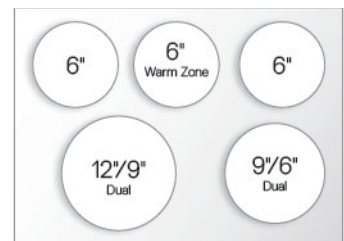

### WFE540H0A 6.2 cu. ft. W | B | S | H | E

- TimeSavor™ convection
- AquaLift® self-clean technology
- EasyView™ extra-large oven window
- Hidden bake element with thermal vents
- Energy Save mode
- AccuBake® temperature management system
- Eco-friendly ceramic glass cooktop\*
- Storage drawer

\*Glass cooktop surface manufactured without the release of hazardous metals into the earth.

Step-up features highlighted by yellow bar

## Freestanding Electric Ranges

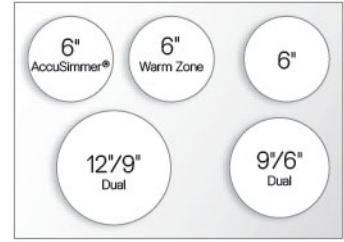

### WFE710H0A 6.2 cu. ft. S | H | E

Whirlpool Gold® model

TimeSaver™ Plus true convection

Rapid Preheat

AccuSimmer® radiant element

Adjustable split rack

Convection Conversion

AccuBake® temperature management system

AquaLift® self-clean technology

EasyView™ extra-large oven window

Hidden bake element with thermal vents

Eco-friendly ceramic glass cooktop\*

Energy Save mode

Storage drawer

\*Glass cooktop surface manufactured without the release of hazardous metals into the earth.

Feature descriptions can be found in the glossary on pages 134–137. Complete product specifications can be found on page 141.

## Freestanding Electric Ranges

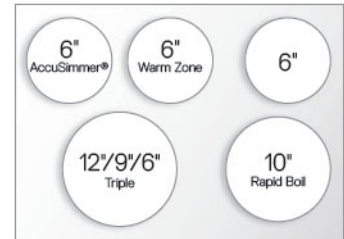

### WFE720H0A 6.2 cu. ft. S

Whirlpool Gold® model

Rapid Boil element

Adjustable warming drawer with handle

AccuBake® temperature management system

TimeSaver™ Plus true convection

AquaLift® self-clean technology

Rapid Preheat

AccuSimmer® radiant element

EasyView™ extra-large oven window

Adjustable split rack

Convection Conversion

Hidden bake element with thermal vents

Eco-friendly ceramic glass cooktop\*

Energy Save mode



\*Glass cooktop surface manufactured without the release of hazardous metals into the earth.

Step-up features  
highlighted by  
yellow bar

## Freestanding Electric Ranges

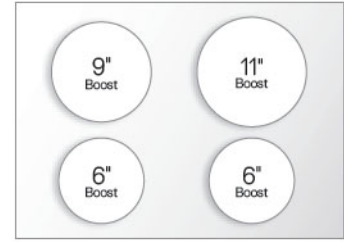

### WF1910H0A 6.2 cu. ft. Induction Range S

Whirlpool Gold® model

#### AccuHeat™ induction technology

AccuBake® temperature management system

TimeSavor™ Plus true convection

AquaLift® self-clean technology

Rapid Preheat

EasyView™ extra-large oven window

Adjustable split rack

Convection Conversion

Hidden bake element with thermal vents

Adjustable warming drawer with handle

Ceramic glass cooktop

Energy Save mode

Feature descriptions can be found in the glossary on pages 134–137. Complete product specifications can be found on page 141.



## Freestanding Gas Ranges



|        |       |
|--------|-------|
| 9,500  | 9,500 |
| 11,500 | 9,500 |

### WFG114SW 4.4 cu. ft. Q | B

- Cast-iron grates
- Standard oven window
- Broiler drawer



|       |               |       |
|-------|---------------|-------|
| 7,000 | 7,500<br>Oval | 7,000 |
| 8,000 |               | 7,000 |

### WFG231LV 4.4 cu. ft. Q | B | S

- Large oven window
- Center griddle included
- 7,500-BTU Oval burner
- Cast-iron grates
- Broiler drawer

Step-up features highlighted by yellow bar

## Freestanding Gas Ranges



|                  |                      |
|------------------|----------------------|
| 9,500            | 5,000<br>AccuSimmer® |
| 13,500<br>Power™ | 9,500                |

### WFG510S0A 5.0 cu. ft. W | B | T | D | S

- AccuBake® temperature management system
- Traditional self-cleaning system
- 13,500-BTU Power™ burner
- 5,000-BTU AccuSimmer® burner
- Satin-finish, cast-iron grates
- Storage drawer
- Large oven window



|                  |                      |
|------------------|----------------------|
| 9,500            | 5,000<br>AccuSimmer® |
| 15,000<br>Power™ | 15,000<br>Power™     |

### WFG520S0A 5.0 cu. ft. W | B | S

- Multiple 15,000-BTU Power™ burners
- Full-width, satin-finish cast-iron grates
- AccuBake® temperature management system
- 5,000-BTU AccuSimmer® burner
- Traditional self-cleaning system
- Large oven window
- Storage drawer

NOTE: Cooktop BTUs are listed for each model.

Feature descriptions can be found in the glossary on pages 134–137. Complete product specifications can be found on page 142.

## Freestanding Gas Ranges



### WFG540H0A 5.8 cu. ft. W | B | S | H | E

- TimeSavor™ convection
- AquaLift® self-clean technology
- EasyView™ extra-large oven window
- 17,000-BTU and 15,000-BTU Power™ burners
- Energy Save mode
- Middle burner
- AccuBake® temperature management system
- 5,000-BTU AccuSimmer® burner
- Full-width, satin-finish cast-iron grates
- Storage drawer



### WFG710H0A 5.8 cu. ft. S | H | E

- Whirlpool Gold® model
- Rapid Preheat
- Adjustable split rack
- Convection Conversion
- Side-integrated griddle included
- AccuBake® temperature management system
- TimeSavor™ convection
- AquaLift® self-clean technology
- EasyView™ extra-large oven window
- 17,000-BTU and 15,000-BTU Power™ burners
- 5,000-BTU AccuSimmer® burner
- Full-width, satin-finish cast-iron grates
- Energy Save mode
- Middle burner
- Storage drawer



Step-up features highlighted by yellow bar

## Freestanding Gas Ranges



### WFG720H0A 5.8 cu. ft. S

Whirlpool Gold® model

TimeSaver™ Plus true convection

Adjustable warming drawer with handle

AccuBake® temperature management system

AquaLift® self-clean technology

Rapid Preheat

EasyView™ extra-large oven window

17,000-BTU and 15,000-BTU Power™ burners

5,000-BTU AccuSimmer® burner

Adjustable split rack

Convection Conversion

Side-integrated griddle included

Full-width, satin-finish cast-iron grates

Energy Save mode

Middle burner



NOTE: Cooktop BTUs are listed for each model.

Feature descriptions can be found in the glossary on pages 134–137. Complete product specifications can be found on page 142.



## Slide-In Electric Ranges

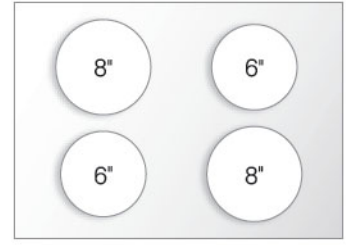

### **RY160LXT 4.3 cu. ft. Q | B | S**

Precise Clean™ self-cleaning system  
Extra-large oven window



### **GY397LXU 4.5 cu. ft. Q | B | S**

Whirlpool Gold® model  
**AccuBake® temperature management system**  
**Eco-friendly ceramic glass cooktop\***  
Precise Clean™ self-cleaning system  
Extra-large oven window

\*Glass cooktop surface manufactured without the release of hazardous metals into the earth.

Step-up features  
highlighted by  
yellow bar

## Slide-In Electric Ranges

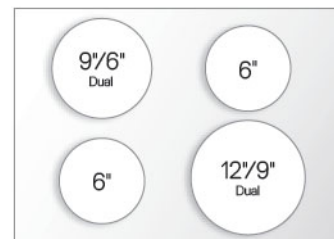

### **GY399LXU 4.5 cu. ft. Q | B | S**

Whirlpool Gold® model

TimeSaver™ Plus true convection

Hidden bake element

AccuBake® temperature management system

Precise Clean™ self-cleaning system

Extra-large oven window

Eco-friendly ceramic glass cooktop\*

\*Glass cooktop surface manufactured without the release of hazardous metals into the earth.

Feature descriptions can be found in the glossary on pages 134–137. Complete product specifications can be found on page 143.

## Slide-In Gas Ranges



|       |                  |
|-------|------------------|
| 5,000 | 9,200            |
| 9,200 | 14,000<br>Power™ |

### GW397LXU 4.5 cu. ft. Q | B | S

- Whirlpool Gold® model
- AccuBake® temperature management system
- Precise Clean™ self-cleaning system
- Extra-large oven window
- 14,000-BTU Power™ burner
- Continuous satin-finish, cast-iron grates
- Hidden bake element
- ADA compliant\*



|                  |                  |
|------------------|------------------|
| 5,000            | 9,200            |
| 12,500<br>Power™ | 16,000<br>Power™ |

### GW399LXU 4.5 cu. ft. Q | B | S

- Whirlpool Gold® model
- TimeSavor™ Plus true convection**
- 16,000-BTU and 12,500-BTU Power™ burners**
- AccuBake® temperature management system
- Precise Clean™ self-cleaning system
- Extra-large oven window
- Continuous satin-finish, cast-iron grates
- Hidden bake element

NOTE: Cooktop BTUs are listed for each model.

\*Model meets applicable ADA requirements and must be installed in compliance with the current ADA Standards.

Step-up features  
highlighted by  
yellow bar

## Drop-In Electric Ranges

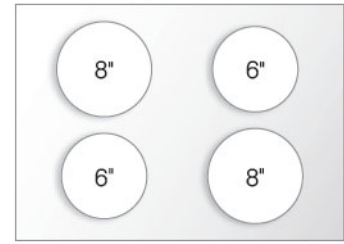

### WDE150LV 4.5 cu. ft. Q | B | S

- AccuBake® temperature management system
- Self-cleaning system with Delay Clean
- Large oven window

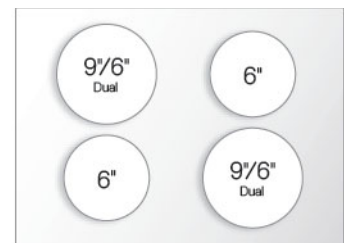

### WDE350LV 4.5 cu. ft. Q | B | S

- Eco-friendly ceramic glass cooktop\*\*
- AccuBake® temperature management system
- Self-cleaning system with Delay Clean
- Large oven window

\*\*Glass cooktop surface manufactured without the release of hazardous metals into the earth.

Feature descriptions can be found in the glossary on pages 134–137. Complete product specifications can be found on pages 143–144.





## WALL OVENS



### Seals in flavors and bakes evenly

TimeSavor™ Ultra true convection uses a rear fan, a third 2,500-watt heating element and an innovative X-shaped baffle to distribute heated air more efficiently in four directions. The AccuBake® system also surrounds food with even temperatures to achieve consistent results every time.



### Cleans easily

The SteamClean option makes cleanup easy. It spot cleans everyday light spills using only heat and 1-1/4 cups of water—no harsh chemicals or cleaners needed.



### Easy-to-install sophisticated design

Replacing your wall oven just got easier. With the FIT system, your wall oven can fit seamlessly into your current cabinet cutout.\* This sleek finish is complemented by modern handles and color options that add a sophisticated look to any kitchen.



### Largest capacity wall oven available\*\*

Cook multiple dishes for a large family meal or prepare treats for a bake sale with double oven capacities of up to 10.0 total cu. ft. Now there's plenty of room to handle even your largest cooking tasks.

NOTE: Not all features are available on all models.

\*Available on 27" and 30" double and single wall ovens. See product specifications for minimum and maximum installation dimensions.

\*\*Among leading brand 27" or 30" wall ovens.

## Single Wall Ovens



**RBS245PR 24" 3.1 cu. ft. Q | B | S**

AccuBake® temperature management system  
Large oven window

**RATED A  
BEST  
BUY\***



**WOS51EC0A 30" 5.0 cu. ft. W | B | T | S**

**WOS51EC7A 27" 4.3 cu. ft. W | B | S**

SteamClean option  
FIT system  
EasyView™ extra-large oven window  
Hidden bake element  
AccuBake® temperature management system

\*According to a leading consumer magazine, model WOS51EC0A only. \*\*FIT System Limited Guarantee: If our 27" or 30" standard single or double wall ovens featuring the FIT System do not fit your existing cabinet cut-out of a compatible width and configuration, contact us within 30 days of the purchase date and receive up to \$250 toward the cost of professional cabinet modification. Valid for qualified replacement models purchased between 5/1/12-12/31/14; excludes new cabinet installations. Visit [whirlpool.com/fitsystemlimitedguarantee](http://whirlpool.com/fitsystemlimitedguarantee) for complete details.

Step-up features  
highlighted by  
yellow bar



All 27" and 30" single oven models are backed by the FIT System Limited Guarantee to fit your existing cabinet cutout.\*\*

## Single Wall Ovens

#1  
RATED†



**WOS92EC0A 30" 5.0 cu. ft. B | S | H | E**  
**WOS92EC7A 27" 4.3 cu. ft. W | B | S**

Whirlpool Gold® model

TimeSaver™ Ultra true convection

Rapid Preheat

Convection Conversion

AccuBake® temperature management system

SteamClean option

FIT system

EasyView™ extra-large oven window

Hidden bake element

†According to a leading consumer magazine, model WOS92EC0A only.

Feature descriptions can be found in the glossary on pages 134–137. Complete product specifications can be found on page 145.



## Double Wall Ovens



**RBD245PR 24" 6.2 total cu. ft. Q | B | S**

AccuBake® temperature management system  
Large oven window

RATED A  
RECOMMENDED BUY\*



**WOD51EC0A 30" 10.0 total cu. ft. W | B | S**  
**WOD51EC7A 27" 8.6 total cu. ft. W | B | S**

SteamClean option  
FIT system  
EasyView™ extra-large oven window  
Hidden bake element  
AccuBake® temperature management system

\*According to a leading consumer magazine, model WOD51EC0A. \*\*FIT System Limited Guarantee: If our 27" or 30" standard single or double wall ovens featuring the FIT System do not fit your existing cabinet cut-out of a compatible width and configuration, contact us within 30 days of the purchase date and receive up to \$250 toward the cost of professional cabinet modification. Valid for qualified replacement models purchased between 5/1/12-12/31/14; excludes new cabinet installations. Visit [whirlpool.com/fitsystemlimitedguarantee](http://whirlpool.com/fitsystemlimitedguarantee) for complete details.

Step-up features  
highlighted by  
yellow bar



All 27" and 30" double oven models are backed by the FIT System Limited Guarantee to fit your existing cabinet cutout.\*\*

## Double Wall Ovens

#1  
RATED†



**WOD93EC0A 30" 10.0 total cu. ft. B | S | H | E**  
**WOD93EC7A 27" 8.6 total cu. ft. W | B | S**

Whirlpool Gold® model

TimeSavor™ Ultra true convection

Rapid Preheat

Convection Conversion

AccuBake® temperature management system

SteamClean option

FIT system

EasyView™ extra-large oven window

Hidden bake element

†According to a leading consumer magazine, model WOD93EC0A only.

Feature descriptions can be found in the glossary on pages 134–137. Complete product specifications can be found on page 146.

## Combination Microwave Wall Ovens



**WOC54EC0A 30" 6.4 total cu. ft. W | B | S**  
**WOC54EC7A 27" 5.7 total cu. ft. W | B | S**

AccuBake® temperature management system  
SteamClean option  
EasyView™ extra-large oven window  
Hidden bake element  
Sensor microwave with drop-down door

Step-up features  
highlighted by  
yellow bar

## Combination Microwave Wall Ovens



**WOC95EC0A 30" 6.4 total cu. ft. B | S | H | E**

Whirlpool Gold® model

TimeSavor™ Ultra true convection

Rapid Preheat

Convection Conversion

AccuBake® temperature management system

SteamClean option

EasyView™ extra-large oven window

Hidden bake element

Sensor microwave with drop-down door

---

Feature descriptions can be found in the glossary on pages 134–137. Complete product specifications can be found on page 147.





G7CG3665XS

## COOKTOPS



### Offers flexible cooking options

Select gas cooktops feature a 17,000-BTU Flex Power™ burner that achieves high heat to quickly boil water. You can also simmer, sear and melt quickly and easily with the 30" electric cooktop with five elements and features like triple radiant elements and bridge elements.



### Precise temperature control

Master your most delicate dishes with the precise temperature control from AccuSimmer® elements and burners. You can also easily melt butter, cook custards and simmer sauces. The AccuSimmer® Plus element offers accurate control, reaching lower temperatures.



### Delivers innovative AccuHeat™ induction technology

Select cooktops feature AccuHeat™ induction technology and transfer energy directly into cookware with magnetic bases. Now our most energy-efficient cooktops ever offer faster, more energy-efficient cooking. And since the cooking surface cools down fast, spills won't bake onto it.



### Boils water in up to half the time\*

The Boost function dramatically increases power for greater cooking flexibility and immediate responsiveness. Faster boiling helps you prepare pasta, soup and water for tea more quickly. You'll even sauté and fry faster, too.

NOTE: Not all features are available on all models.

\*Compared to boiling 3.6 liters of water with a traditional 9" 2,500-watt radiant element or a 12,500-BTU gas burner.

## Electric Cooktops

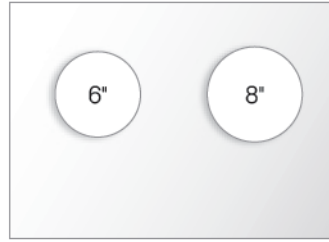

### RCS2012R 21" S

- High-speed coil elements
- Infinite heat controls
- Chrome drip bowls



### WCC31430A 30" W | B | R

- Dishwasher-safe control knobs
- No Drip chrome drip bowls
- High-speed coil elements
- Infinite heat controls

Step-up features  
highlighted by  
yellow bar

## Electric Cooktops

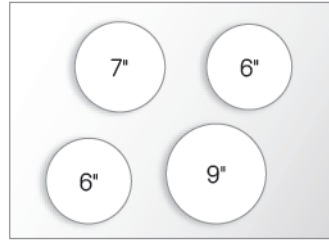

### W5CE3024X 30" W | B | S

Eco-friendly ceramic glass cooktop\*

Ceramic glass radiant elements

Dishwasher-safe control knobs

Infinite heat controls

RATED A  
BEST  
BUY\*\*



### G7CE3034X 30" P | B | C | S

Whirlpool Gold® model

AccuSimmer® dual radiant element

Dishwasher-safe, stainless steel finish control knobs†

Ceramic glass radiant elements

Eco-friendly ceramic glass cooktop\*

Infinite heat controls

\*Glass cooktop surface manufactured without the release of hazardous metals into the earth. \*\*According to a leading consumer magazine. †Stainless Steel models only.

Feature descriptions can be found in the glossary on pages 134–137. Complete product specifications can be found on page 148.



## Electric Cooktops

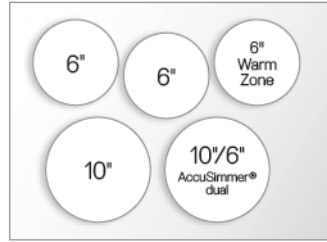

### G7CE3055X 30" B | S

Whirlpool Gold® model

5 ceramic glass radiant elements

Warm Zone element

Eco-friendly ceramic glass cooktop\*

AccuSimmer® dual radiant element

Dishwasher-safe, stainless steel finish control knobs\*\*

Infinite heat controls

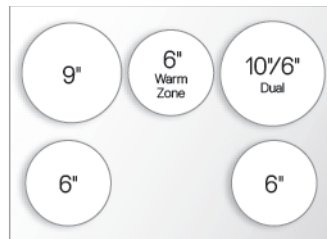

### G9CE3065X 30" B | S

Whirlpool Gold® model

AccuSimmer® Plus feature on all elements

Tap Touch controls

Control lock

ADA compliant†

5 ceramic glass radiant elements

Eco-friendly ceramic glass cooktop\*

Dual radiant element

Warm Zone element

\*Glass cooktop surface manufactured without the release of hazardous metals into the earth. \*\*Stainless Steel models only. †Meets ADA push/pull force and reach guidelines.

Step-up features  
highlighted by  
yellow bar

## Electric Cooktops

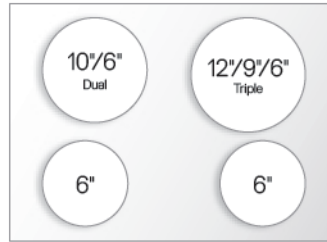

### **G9CE3074X 30" B**

Whirlpool Gold® model

#### **Triple radiant element**

- Ceramic glass radiant elements
- Eco-friendly ceramic glass cooktop\*
- AccuSimmer® Plus feature on all elements
- Tap Touch controls
- Dual radiant element
- Control lock
- ADA compliant†

RATED A  
**BEST  
BUY**™



### **GCI3061X 30" Induction Cooktop B**

Whirlpool Gold® model

#### **Boost function element**

- AccuHeat™ induction technology
- Automatic pan detection
- Ceramic glass cooktop
- Tap Touch controls
- Control lock
- ADA compliant†

\* Glass cooktop surface manufactured without the release of hazardous metals into the earth. †Meets ADA push/pull force and reach guidelines. ††According to a leading consumer magazine.

Feature descriptions can be found in the glossary on pages 134–137. Complete product specifications can be found on pages 148–149.

## Electric Cooktops

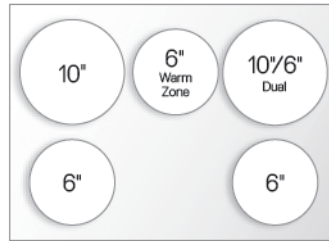

### W5CE3625A 36" B

- 5 ceramic glass radiant elements
- Eco-friendly ceramic glass cooktop\*
- Dishwasher-safe control knobs
- Dual radiant element
- Warm Zone element
- Infinite heat controls



### G7CE3635X 36" B | S

- Whirlpool Gold® model
- AccuSimmer® dual radiant element**
- Dishwasher-safe, stainless steel finish control knobs\*\*
- Multiple dual radiant elements**
- 5 ceramic glass radiant elements
- Eco-friendly ceramic glass cooktop\*
- Warm Zone element
- Infinite heat controls

\*Glass cooktop surface manufactured without the release of hazardous metals into the earth. \*\*Stainless Steel models only.

Step-up features  
highlighted by  
yellow bar

## Electric Cooktops



### **G9CE3675X 36" B | S**

Whirlpool Gold® model

AccuSimmer® Plus feature on all elements

Tap Touch controls

Triple radiant element

Control lock

ADA compliant†

5 ceramic glass radiant elements

Eco-friendly ceramic glass cooktop\*

Dual radiant element

\*Glass cooktop surface manufactured without the release of hazardous metals into the earth. †Meets ADA push/pull force and reach guidelines.

Feature descriptions can be found in the glossary on pages 134–137. Complete product specifications can be found on page 149.



## Gas Cooktops



|        |                      |
|--------|----------------------|
| 9,100  | 9,100                |
| 10,500 | 5,000<br>AccuSimmer® |

### W3CG3014X 30" W | B | S

Porcelain or stainless steel cooktop  
 5,000-BTU AccuSimmer® burner  
 Dishwasher-safe, enamel steel grates  
 Control knobs  
 Sealed burners  
 Infinite heat controls  
 ADA compliant\*



|                      |                  |
|----------------------|------------------|
| 12,500<br>Power™     | 9,200            |
| 5,000<br>AccuSimmer® | 12,500<br>Power™ |

### W5CG3024X 30" W | B | S

Dishwasher-safe, full-width cast-iron grates  
 Dishwasher-safe control knobs  
 Multiple 12,500-BTU Power™ burners  
 Porcelain or stainless steel cooktop  
 5,000-BTU AccuSimmer® burner  
 Sealed burners  
 Infinite heat controls  
 ADA compliant\*

\*Meets ADA push/pull force and reach guidelines.

Step-up features  
 highlighted by  
 yellow bar

## Gas Cooktops



|                  |                      |
|------------------|----------------------|
| 9,100            | 6,000<br>AccuSimmer® |
| 12,500<br>Power™ | 12,500<br>Power™     |

### GLT3057R 30" B

Whirlpool Gold® model

#### 6,000-BTU AccuSimmer® burner

Tempered glass cooktop

Dishwasher-safe, full-width cast-iron grates

Dishwasher-safe control knobs

Sealed burners

Multiple 12,500-BTU Power™ burners

Infinite heat controls

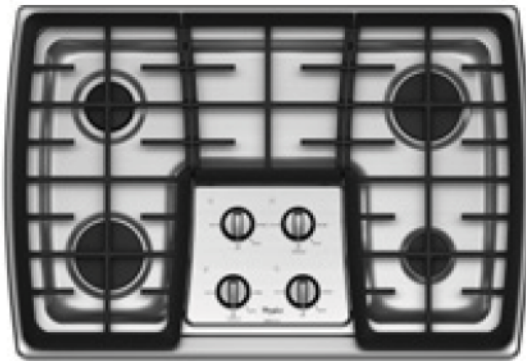

|                  |                      |
|------------------|----------------------|
| 9,200            | 15,000<br>Power™     |
| 17,000<br>Power™ | 5,000<br>AccuSimmer® |

### G7CG3064X 30" S

Whirlpool Gold® model

#### 17,000-BTU and 15,000-BTU Power™ burners

Dishwasher-safe, stainless steel finish control knobs

#### ADA compliant\*

Stainless steel cooktop

5,000-BTU AccuSimmer® burner

Dishwasher-safe, full-width cast-iron grates

Sealed burners

Infinite heat controls

NOTE: Cooktop BTUs are listed for each model.

\*Meets ADA push/pull force and reach guidelines.

Feature descriptions can be found in the glossary on pages 134–137. Complete product specifications can be found on page 150.

## Gas Cooktops



|       |                      |                  |
|-------|----------------------|------------------|
| 9,200 | 5,000<br>AccuSimmer® | 9,200            |
| 9,200 |                      | 12,500<br>Power™ |

### W5CG3625X 36" B | S

Porcelain or stainless steel cooktop  
 Dishwasher-safe, full-width cast-iron grates  
 Dishwasher-safe control knobs  
 Sealed burners  
 5,000-BTU AccuSimmer® burner  
 12,500-BTU Power™ burner  
 Infinite heat controls  
 ADA compliant\*



|                      |       |                      |
|----------------------|-------|----------------------|
| 6,000<br>AccuSimmer® | 9,100 | 6,000<br>AccuSimmer® |
| 12,500<br>Power™     |       | 12,500<br>Power™     |

### GLT3657R 36" B

Whirlpool Gold® model  
**Multiple 6,000-BTU AccuSimmer® burners**  
**Multiple 12,500-BTU Power™ burners**  
 Tempered glass cooktop  
 Dishwasher-safe, full-width cast-iron grates  
 Dishwasher-safe control knobs  
 Sealed burners  
 Infinite heat controls

\*Meets ADA push/pull force and reach guidelines.

Step-up features  
 highlighted by  
 yellow bar

## Gas Cooktops

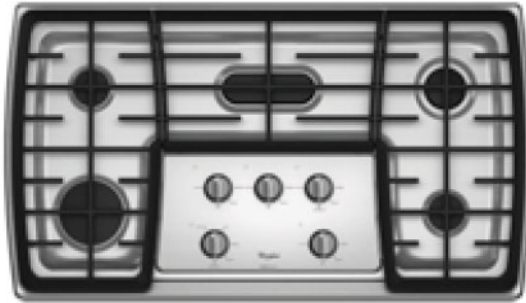

|                       |               |                      |
|-----------------------|---------------|----------------------|
| 5,000<br>AccuSimmer®  | 9,000<br>Oval | 12,500<br>Power™     |
| 17,000<br>Flex Power™ |               | 5,000<br>AccuSimmer® |

### **G7CG3665X 36" S**

Whirlpool Gold® model

17,000-BTU Flex Power™ burner

Dishwasher-safe, stainless steel finish control knobs

9,000-BTU Oval burner

ADA compliant\*

Stainless steel cooktop

Multiple 5,000-BTU AccuSimmer® burners

Dishwasher-safe, full-width cast-iron grates

Sealed burners

12,500-BTU Power™ burner

Infinite heat controls

NOTE: Cooktop BTUs are listed for each model.

\* Meets ADA push/pull force and reach guidelines.

Feature descriptions can be found in the glossary on pages 134–137. Complete product specifications can be found on page 150.



## Gas Cooktops

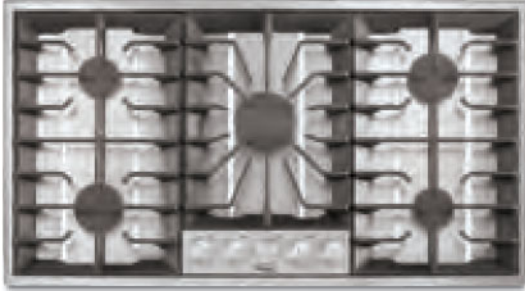

|                  |                  |                  |
|------------------|------------------|------------------|
| 9,000            | 15,000<br>Power™ | 12,000<br>Power™ |
| 12,000<br>Power™ |                  | 9,000            |

### GLS3665R 36" S

Whirlpool Gold® model

15,000-BTU and multiple 12,000-BTU Power™ burners

Recessed grate design

Stainless steel cooktop

Dishwasher-safe, full-width cast-iron grates

Stainless steel finish control knobs

Sealed burners

Infinite heat controls

Step-up features  
highlighted by  
yellow bar

## Modular Cooktop

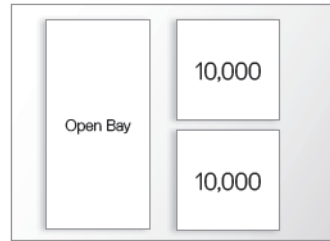

### **SC8720ED 30" Modular Cooktop B**

Modular porcelain cooktop surface

Dishwasher-safe, lift-off control knobs

Infinite heat controls

Downdraft vent

Removable/washable vent filter

Optional modules available: surface burner, non-stick grill and non-stick griddle\*

NOTE: Cooktop BTUs are listed for each model.

\*Cooktop is shipped with one open bay and two fixed burners. Select from the module options to complete your cooktop

Feature descriptions can be found in the glossary on pages 134–137. Complete product specifications can be found on page 150–151.



WMH53520AE

## MICROWAVES



### **Adjusts cooking time for optimal results**

With the push of a single button, Sensor cooking tracks the progress of your food. It automatically adjusts cooking time as needed so you won't have to micro-manage your microwave.



### **Senses cooktop heat**

Select Whirlpool® microwaves automatically adjust fan speed by sensing cooktop heat. Models with the Auto Adapt fan also offer variable fan speeds so you can match the right amount of ventilation to the dish being prepared.



### **Seals in flavors and juices**

TimeSavor™ Plus true convection cooks food evenly with juicy, flavorful results. It uses a rear fan to circulate preheated air over, under and around food.



### **Convenient steaming**

Enjoy flaky fish, tender vegetables and fluffy rice quickly and easily with Steam cooking. Now you can steam in the microwave using the available steamer accessory for delicious, healthy meals.

NOTE: Not all features are available on all models.



## Microwave Hood Combinations



**WMH31017A 1.7 cu. ft. W | B | D | S**

Recessed glass turntable  
EZ-View™ lighting



**WMH32517A 1.7 cu. ft. W | B | T | S**

Sensor cooking  
Steam cooking  
Recessed, stoppable glass turntable  
AccuSimmer® cycle  
Cooking rack  
EZ-View™ lighting

Step-up features  
highlighted by  
yellow bar

## Microwave Hood Combinations



### **WMH53520A 2.0 cu. ft. W | B | S | H | E**

- Auto Adapt fan
- CleanRelease® non-stick interior
- Sensor cooking
- Steam cooking
- Recessed, stoppable glass turntable
- AccuSimmer® cycle
- Cooking rack
- EZ-View™ lighting



### **WMH75520A 2.0 cu. ft. W | B | S**

- Whirlpool Gold® model
- AccuWave® power system
- Sensor cooking
- Steam cooking
- CleanRelease® non-stick interior
- Recessed, stoppable glass turntable
- AccuSimmer® cycle
- Cooking rack
- EZ-View™ lighting

---

Feature descriptions can be found in the glossary on pages 134–137. Complete product specifications can be found on page 152.

## Microwave Hood Combinations



### **WMH76718A 1.8 cu. ft. W | B | S**

Whirlpool Gold® model

TimeSavor™ Plus true convection

Cooking and convection racks

Sensor cooking

Steam cooking

CleanRelease® non-stick interior

Recessed, stoppable glass turntable

AccuSimmer® cycle

EZ-View™ lighting



### **GH7208XR 2.0 cu. ft. S**

Whirlpool Gold® model

Velos® SpeakCook oven

AccuWave® power system

SpeedCook technology with grilling

Convection and grill racks

Halogen lighting

Touch screen controls

Sensor cooking

TimeSavor™ Plus true convection

Steam cooking

CleanRelease® non-stick interior

Recessed, stoppable glass turntable

AccuSimmer® cycle

Step-up features  
highlighted by  
yellow bar

## Countertop Microwaves



**WMC10007A 0.7 cu. ft. W | B**

- Turntable
- Electronic touch controls
- Add-a-Minute option
- Control lock



**WMC10511A 1.1 cu. ft. W | B**

- Sensor cooking
- Large glass turntable
- Add 30 seconds option
- Electronic touch controls
- Control lock

---

Feature descriptions can be found in the glossary on pages 134–137. Complete product specifications can be found on pages 152–153.



## Countertop Microwaves



**WMC11511A 1.1 cu. ft. S**

- Sensor cooking
- Large glass turntable
- Electronic touch controls
- Add 30 seconds option
- Control lock



**WMC30516A 1.6 cu. ft. W | B | S**

- Sensor cooking
- Large glass turntable
- Electronic touch controls
- Add 30 seconds option
- Control lock

---

Step-up features  
highlighted by  
yellow bar

## Countertop Microwaves



**WMC20005Y 0.5 cu. ft. W | B | D**

- Tap Touch controls
- Rounded-back design
- Glass turntable
- Add 30 seconds option
- Control lock



**WMC50522A 2.2 cu. ft. W | B | S**

- Sensor cooking
- Large recessed glass turntable
- Electronic touch controls
- Add 30 seconds option
- Control lock

---

Feature descriptions can be found in the glossary on pages 134–137. Complete product specifications can be found on page 153.

## Under Cabinet Hoods



### **UXT2030AY 30" Traditional W | B**

Up to 190 CFM  
Axial fan  
Top venting only  
Dishwasher-safe grease filter  
2-speed rocker switch controls  
Incandescent light



### **UXT3030AY 30" Traditional W | B**

**Top and rear venting**  
Up to 190 CFM  
Axial fan  
Dishwasher-safe grease filter  
2-speed rocker switch controls  
Incandescent light

Step-up features  
highlighted by  
yellow bar

## Under Cabinet Hoods



**UXT4030AY 30" Traditional W | B | T | S**  
**UXT4036AY 36" Traditional W | B**

- Recirculation kit/Charcoal filter included
- Axial fan
- Recirculating only
- 2-speed rocker switch controls
- Incandescent light



**UXT4230AY 30" Traditional W | B | T | S**  
**UXT4236AY 36" Traditional W | B | S**

- Up to 225 CFM
- Convertible (recirculating or vented)
- Dishwasher-safe grease filter
- Variable-speed rotary controls
- Adjustable incandescent light
- Axial fan
- Optional Recirculation kit/Charcoal filter

---

Feature descriptions can be found in the glossary on pages 134–137. Complete product specifications can be found on page 154.

## Under Cabinet Hoods



**UXT5230AY 30" Traditional W | B | S**  
**UXT5236AY 36" Traditional S**

- Up to 350 CFM
- 3-speed push-button controls
- Adjustable halogen light
- Axial fan
- Convertible (recirculating or vented)
- Dishwasher-safe grease filter
- Optional Recirculation kit/Charcoal filter



**UXT5530AA 30" High Performance S**  
**UXT5536AA 36" High Performance S**

- Up to 400 CFM
- Centrifugal fan
- Multiple dishwasher-safe grease filters
- Recirculation kit/Charcoal filter included
- Convertible (recirculating or vented)
- 3-speed push-button controls
- Adjustable halogen light

Step-up features highlighted by yellow bar



Select Whirlpool® hoods are ENERGY STAR® qualified.



## Under Cabinet Hoods



### **GXU7130DX 30" Traditional S**

Whirlpool Gold® model

ENERGY STAR® qualified

Fluorescent light

Up to 300 CFM

Centrifugal fan

Vented only

Multiple dishwasher-safe grease filters

3-speed push-button controls

---

Feature descriptions can be found in the glossary on pages 134–137. Complete product specifications can be found on page 154.

## Canopy Hoods



**GXW6530DX 30" Glass Wall Mounted S**  
**GXW6536DX 36" Glass Wall Mounted S**

Whirlpool Gold® model  
Up to 400 CFM  
Centrifugal fan  
Convertible (recirculating or vented)  
Dishwasher-safe grease filter  
3-speed push-button controls  
Incandescent light  
Optional Recirculation kit/Charcoal filter



**UXW6530BS 30" Glass Wall Mounted S**  
**UXW6536BS 36" Glass Wall Mounted S**

Up to 400 CFM  
Centrifugal fan  
Convertible (recirculating or vented)  
Dishwasher-safe grease filter  
3-speed push-button controls  
Incandescent light  
Optional Recirculation kit/Charcoal filter

Step-up features highlighted by yellow bar



Select Whirlpool® hoods are ENERGY STAR® qualified.

## Canopy Hoods



### **GXI6536DX 36" Glass Island S**

Whirlpool Gold® model

#### **Halogen light**

Up to 400 CFM

Centrifugal fan

Convertible (recirculating or vented)

Dishwasher-safe grease filter

3-speed push-button controls

Optional Recirculation kit/Charcoal filter



### **UXI6536BS 36" Glass Island S**

Up to 400 CFM

Centrifugal fan

Convertible (recirculating or vented)

Dishwasher-safe grease filter

3-speed push-button controls

Halogen light

Optional Recirculation kit/Charcoal filter

---

Feature descriptions can be found in the glossary on pages 134–137. Complete product specifications can be found on page 155.

## Canopy Hoods



### **GXW7230DA 30" Wall Mounted S**

Whirlpool Gold® model

**Multiple dishwasher-safe grease filters**

Up to 400 CFM

Centrifugal fan

Convertible (recirculating or vented)

3-speed push-button controls

Adjustable incandescent light

Optional Recirculation kit/Charcoal filter



### **UXW7230BS 30" Wall Mounted S**

Up to 400 CFM

Centrifugal fan

Convertible (recirculating or vented)

Multiple dishwasher-safe grease filters

3-speed push-button controls

Adjustable incandescent light

Optional Recirculation kit/Charcoal filter

Step-up features highlighted by yellow bar



Select Whirlpool® hoods are ENERGY STAR® qualified.

## Canopy Hoods



**GXW7330DX 30" Wall Mounted S**

**GXW7336DX 36" Wall Mounted S**

Whirlpool Gold® model

ENERGY STAR® qualified

Fluorescent light

Up to 300 CFM

Centrifugal fan

Convertible (recirculating or vented)

Multiple dishwasher-safe grease filters

3-speed push-button controls

Optional Recirculation kit/Charcoal filter

---

Feature descriptions can be found in the glossary on pages 134–137. Complete product specifications can be found on page 155.



## Downdraft Vent & Hood Liners



**UXD8630DY 30" Pop-Up S**  
**UXD8636DY 36" Pop-Up S**

Up to 600 CFM  
Dual centrifugal fan  
Vented only  
Multiple dishwasher-safe grease filters  
4-speed slider controls

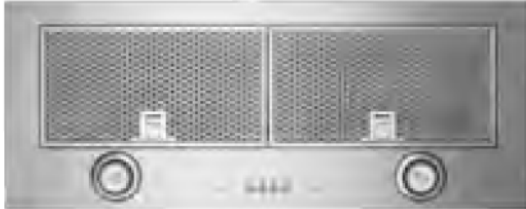

**UXL5430BS 30" Hood Liner S**

Convertible (recirculating or vented)  
Multiple dishwasher-safe grease filters  
3-speed push-button controls  
Halogen lights  
Optional Recirculation kit/Charcoal filter

---

Step-up features  
highlighted by  
yellow bar

## Hood Liners



### **UXL6036YS 36" Hood Liner S**

- Auto-On Heat sensor
- Additional dishwasher-safe grease filter
- 3-speed slider controls
- Adjustable halogen lights
- Vented only



### **UXL6048YS 48" Hood Liner S**

- Additional dishwasher-safe grease filter
- Auto-On Heat sensor
- Vented only
- 3-speed slider controls
- Adjustable halogen lights

---

Feature descriptions can be found in the glossary on pages 134–137. Complete product specifications can be found on pages 156–157.

## Accessories



### affresh® Stainless steel wipes (W10355049)

Disposable wipes gently clean fingerprints, smudges and residue to leave a streak-free, polished shine. Contains 35 use and toss wipes. Size 7" (H) x 9" (W).



### affresh® Cooktop cleaner (W10355051) and Replacement Scrubbing Pads (W10391473)

Cuts through tough, baked-on residue. Safe for all glass and ceramic cooktops. Replacement pads used to remove light soil or water spots, 20-pack.



### affresh® Stainless steel cleaner (W10355016)

This spray cleaner gently cleans fingerprints, smudges and other residue from Stainless Steel surfaces to leave a streak-free, polished shine.



### affresh® Kitchen & appliance cleaner (W10355010)

This spray cleaner cuts through everyday spills to leave a streak-free shine. Easily cleans inside refrigerator and microwave ovens. Now with a fresh, citrus scent.



### Gourmet Griddle (4396096RB)

An easy-to-clean, non-stick griddle for electric coil, gas and ceramic glass ranges. Place over two elements or burners for great grilled sandwiches or other dishes.



### Microwave Crisper Pan (W10187336A)

Prepare crisp bacon, potatoes or pizza in the microwave with this pan. 12-1/4" (Diameter) and 1-1/2" (Deep).



### Baking Stone (4378577)

This 13" baking stone evenly distributes heat and moisture for lighter, crispier food. Suitable for use in regular, convection and microwave ovens.



### Universal Microwave Steamer (8205262RB)

Works in tandem with the steaming function to conveniently steam foods such as rice, vegetables and fish with fresh, pleasing results. 13-3/4" (H) x 8-1/2" (W) x 5-1/4" (D).



### 30" Range Oven Rack (W10273852A)

Replace a standard cooking rack in Whirlpool® double oven ranges with this roll-out rack. Its easy-gliding design makes it simple to retrieve dishes from a hot oven.

Offers enough strength to support two 16-lb turkeys.



### Oven Cleaning Kit Retail polybag: W10423113RP Retail box: W10510627RB Factory Certified Parts polybag: W10432017BU

Offers everything you need to clean both gas and electric ovens featuring Aqualift® self-clean technology. Includes (1) scraper, (1) scrubbing sponge and (1) expanding sponge.



### Heavy Duty Sliding Rack 30" Wall Ovens: W10282973A 27" Wall Ovens: W10282974A

### Heavy Duty Sliding Rack with handle 30" Wall Ovens: W10282971A 27" Wall Ovens: W10282972A



### Touch-Up Paint White: 72017 Black: 72032 Biscuit: 4392899 Universal Silver: 8212473

Touch up appliance exteriors with this 0.6 fl. oz. bottle of touch-up paint. Includes applicator brush.

To acquire pricing information, order Whirlpool® cooking accessories and determine delivery time, visit [whirlpool.com/accessories](http://whirlpool.com/accessories) or call 1-800-462-3819.

# Accessories

## Countertop Microwave Accessories

| MODEL         | WMC30516A  |
|---------------|--|
| 30" Trim Kit* | White - MK2160AW<br>Black - MK2160AB<br>Stainless - MK2160AS |
| 27" Trim Kit* | White - MK2167AW<br>Black - MK2167AB<br>Stainless - MK2167AS |

| MODEL                           | WMC30516A                               |
|---------------------------------|---|
| 30" Trim Kit cutout dimensions* | 15 3/4" (H) x 28 1/2" (W) x 18 1/2" (D) |
| 27" Trim Kit cutout dimensions* | 15 3/4" (H) x 25 1/2" (W) x 18 1/2" (D) |

## Range/Oven Accessories

| FILLER KIT | SLIDE-IN/<br>DROP-IN RANGE | DROP-IN RANGE<br>6" BACKSPLASH | 36" MHC OPENING |
|------------|----------------------------|--------------------------------|-----------------|
| White      | FILL52WHT                  | UXA9107AAW                     | 8171336         |
| Black      | FILL52BLK                  | UXA9107AAB                     | 8171337         |
| Biscuit    | FILL52BIS                  | UXA9107AAG                     | 8171338         |
| Stainless  | —                          | JXA912AAP                      | 8171339         |

| MODEL                  | GY397LXU   | GY399LXU   | GW397LXU   | GW399LXU   |
|------------------------|------------|------------|------------|------------|
| Side Panel (White)     | UXA1100AAW | UXA1100AAW | UXA1100AAW | UXA1100AAW |
| Side Panel (Black)     | UXA1100AAB | UXA1100AAB | UXA1100AAB | UXA1100AAB |
| Side Panel (Biscuit)   | UXA1100AAG | UXA1100AAG | UXA1100AAG | UXA1100AAG |
| Side Panel (Stainless) | UXA1100AAS | UXA1100AAS | UXA1100AAS | UXA1100AAS |

## Microwave Hood Combination Charcoal & Grease Filters

- Replace the charcoal or grease microwave hood filter every 6 months to improve air circulation and remove odors
- Measure current filter to assure correct replacement

| AVAILABLE ACCESSORY         | DIMENSIONS (L X W X D) |
|-----------------------------|------------------------|
| Charcoal filter (8206230A)  | 5" x 5 1/4" x 3/8"     |
| Grease filters (W10208631)  | 13 1/2" x 6" x 1/4"    |
| Grease filters (W10113040A) | 12 1/4" x 6" x 1/4"    |

## Wall Oven Accessories

| MODEL                        | WOS51EC0/7A<br>WOS51EC0/7A | WOS92EC0/7A<br>WOS92EC0/7A | WOD51EC0/7A<br>WOD51EC0/7A | WOD93EC0/7A<br>WOD93EC0/7A | WOC54EC0/7A<br>WOC54EC0/7A | WOC95EC0A  |
|------------------------------|----------------------------|----------------------------|----------------------------|----------------------------|----------------------------|------------|
| Side trim cover (left side)  | W10344481A                 | W10344481A                 | W10327369A                 | W10327369A                 | W10344483A                 | W10344483A |
| Side trim cover (right side) | W10344480A                 | W10344480A                 | W10327368A                 | W10327368A                 | W10344482A                 | W10344482A |
| FIT system kit (30" model)   | Included                   | Included                   | Included                   | Included                   | W10495947                  | W10495947  |
| FIT system kit (27" model)   | Included                   | Included                   | Included                   | Included                   | W10495945                  | N/A        |

## Hood & Vent Charcoal Filters

- Replace the charcoal or grease microwave hood filter every 6 months to improve air circulation and remove odors
- Measure current filter to assure correct replacement

| MODEL                       | DIMENSIONS (L X W X D)  | 30" MODEL                           | 36" MODEL              |
|-----------------------------|-------------------------|-------------------------------------|------------------------|
| Charcoal filter (W10355450) | 10 1/2" x 8 3/4" x 1/2" | UXT4030AY<br>UXT4230AY<br>UXT5230AY | UXT4036AY<br>UXT4236AY |
| Charcoal filter (W10272068) | 7 3/8" x 7 3/8"         | UXT5530AA                           | UXT5536AA              |
| Charcoal filter (W10294730) | 7 3/8" x 7 3/8"         | GXW6530DX                           | GXW6536DX<br>GXI6536DX |
| Charcoal filter (W10386873) | 7 3/8" x 7 3/8"         |                                     | UXT5236AY              |

## Hood & Vent Accessories

| UNDER CABINET ACCESSORY**  |           |
|----------------------------|-----------|
| 7" Round damper            | W10355451 |
| 5', 125V 3-wire Power Cord | W10355452 |

| MODEL                   | UXT4030AY<br>UXT4036AY | UXT4230AY<br>UXT4236AY                                    | UXT5230AY<br>UXT5236AY                   | UXT5530AA<br>UXT5536AA                                       | GXW6530DX<br>GXW6536DX | GXI6536DX             |
|-------------------------|------------------------|---|--|--|------------------------|-----------------------|
| Recirculation kit (30") | —                      | White - 4378581<br>Black - 4378581<br>Stainless - 4378581 | Black - 49001180<br>Stainless - 49001196 | White - Included<br>Black - Included<br>Stainless - Included | Stainless - W10294733  | —                     |
| Recirculation kit (36") | —                      | White - 4378581<br>Black - 4378581<br>Stainless - 4378581 |  | White - Included<br>Black - Included<br>Stainless - Included | Stainless - W10294733  | Stainless - W10294734 |
| Chimney extension kit   |                        |   |  |  | W10294735              | W10272078             |

\*Trim kit not available for compact model WMC10007A.  
\*\*Accessories listed here are compatible with models UXT4030/36AY, UXT4230/36AY and UXT5230/36AY.



# Glossary

## **AccuBake® temperature management system**

Achieve uniform baking results every time with the AccuBake® temperature management system. A built-in sensor monitors oven temperature and controls the cooking elements to deliver consistent, delicious results every time.

## **AccuHeat™ induction technology**

Faster, more efficient cooking is available on select freestanding ranges, cooktops and the industry's first induction double oven freestanding range.\* AccuHeat™ induction technology only heats cooking surfaces by transferring energy directly into any cookware with magnetic bases.

## **AccuSimmer® burner/element**

Delivers precise temperature control that is perfect for simmering sauces and soups. Select models feature an AccuSimmer® Plus element that offers more control and reaches your cooktop's lowest temperatures.

## **AccuSimmer® cycle**

Quickly boils liquids in the microwave, then automatically reduces the heat to a delicate simmer to avoid splatters.

## **AccuWave® power system**

Evenly cooks, defrosts, reheats, softens and melts with constant, gentle heat. Thaw chicken without cooking the edges and reheat sauces without splatters.

## **Add 30 Seconds option**

Quickly set the microwave to cook for 30 seconds at 100% power by pressing this button. Or, press it to add 30 seconds to a manual setting that is already in progress.

## **Adjustable split rack**

Remove the rack insert to make room for large items like a turkey or attach it to make a full rack. The insert can also be used on the counter as a cooling rack.

## **Adjustable time self-cleaning system**

Allows for adjustment of the self-clean time in 15-minute intervals, according to your needs.

## **AquaLift® self-clean technology**

Delivers easy, odor-free oven cleaning in only 50 minutes.\*\* Our most energy-efficient self-cleaning cycle available† releases baked-on foods from the bottom of the oven without harsh chemicals or cleaners. When the cleaning cycle is complete, soils and excess water can be easily removed with a dry towel.

## **Auto Adapt fan**

Automatically adjusts fan speed on microwave hood combinations by sensing cooktop heat.

## **Bridge element**

Increases cooking options via a 700-watt bridge element that connects two heating elements. Evenly heat large or oblong pans more easily on the cooktop.

## **Center griddle**

Allows you to warm tortillas, make pancakes or sear fish with a built-in, center griddle.

## **Ceramic glass cooktop**

Withstands intense heat while resisting cracking or chipping, preserving the sleek look of your cooktop for years to come.

## **CleanRelease® non-stick interior**

Reduces cleanup effort because of the non-stick interior—an industry first. No special cleaning solutions are required.

## **Control Bake**

This baking mode keeps the broil element turned off, preventing the tops of your food from overcooking, so pies and turkey come out just right.

## **Control lock**

Disables the control panel to avoid unintended use or other changes to your cooking settings.

## **Convection Conversion**

Removes the guesswork from preparing your favorite dishes by automatically converting standard times and temperatures to the convection equivalent.

## **Convertible ventilation system**

Provides added installation flexibility by venting odors outside or recirculating them, depending upon your preference.

## **Crisper pan with handle**

Provides the ideal cookware for pan-frying foods like bacon or potatoes in the microwave. The patented, non-stick design makes cleanup easy.

## **Custom Broil**

Allows you to set your preferred broiling temperature in 5-degree increments. High heat is best for grilling meats, while low heat is ideal for delicate tasks like melting cheese on lasagna.

## **Delay Bake**

Lets you program the oven to begin cooking at a pre-set time. Prepare food for baking when it's most convenient for you and have dinner ready according to your schedule.

## **Downdraft vent system**

Pulls steam, smoke and odors downward and outside to help clear kitchen air. Conveniently built into select cooktops.

\*Among conventional double oven ranges with dual bake and broil elements. \*\*Based on average cleaning time of self-clean cycle with water and moderate soils. †Versus traditional self clean cycle.



# Glossary

## Dual and Triple radiant elements

Provides the space-saving advantage of having two or three elements in one to handle various sizes of cookware. The inner ring is perfect for simmering or quickly boiling water in small pans. The larger outer ring evenly distributes heat to larger pots and pans for better results.

## Eco-friendly ceramic glass cooktop††

Withstands intense heat while resisting cracking or chipping, preserving the sleek look of your cooktop for years to come. The easy-to-clean surface is manufactured without the release of hazardous metals into the earth.

## Energy Save mode

Similar to the sleep mode on a computer, the Energy Save feature uses less energy compared to ranges without Energy Save. It can be activated to turn off the display after 5 minutes of the range not being used. Press any button and the display becomes active again.

## EZ-View™ lighting

Provides illumination above the range according to your preference with three brightness settings, including a night-light option. Bulbs change out easily when a replacement is needed.

## Filter change indicator light

Informs you when it's time to change the microwave hood combination filter so air stays fresher. No more guessing about when you need to change a filter.

## FIT system

Now your wall oven can fit seamlessly into your current cabinet cutout‡ with this flexible installation system. It provides various options that are designed to effortlessly suit your decor.

## Flex Power™ burner

A 17,000-BTU Flex Power™ burner generates the high heat needed for rapid boiling and searing and provides uniform cooking at lower temperatures for your most delicate dishes, making this our most flexible burner ever.

## Frameless door design

Permits easy exterior cleaning with a flat, frameless panel. No nooks or crannies to catch crumbs.

## Full-width, cast-iron grates

Offers a smooth design for easy cleaning by hand or in the dishwasher. The grates cover the entire cooktop surface, creating the flexibility to place pots and pans anywhere, while the smooth satin finish resists wear and tear.

## Grill rack

Provides the ideal setup when using the grill function of a SpeedCook oven or microwave hood combination, allowing you to place food closer to the grill element for faster cooking. Steaks look and taste as if they were cooked under the oven broiler but are ready in less time.

## Hidden bake element

Simplifies cleanup with the bake element hidden beneath the oven floor, leaving a smooth interior surface that is easy to wipe clean.

## High-speed coil element

Heats up quickly to provide high temperatures for boiling and frying. Chrome drip pans below catch spills for easy cleanup.

## Hot surface indicator

Illuminates when the cooktop surface is still hot to the touch—even after the heating element has been turned off.

## Infinite heat controls

Allow for smooth movement of temperature settings, from low to high. Adjust the heat up or down according to your cooking needs.

## Kids Menu

Cooks a variety of child-friendly food with preprogrammed cycles that are activated by the simple push of a button. With menu selections like hot dogs and chicken nuggets, children can easily prepare their own pre-game dinners or after-school snacks.

## Large/EasyView™ extra-large oven windows

Provides better visibility of the oven interior with a large oven window. Monitor cooking progress without opening the door, keeping oven temperatures steady and undisturbed. Select wall ovens and freestanding ranges feature the EasyView™ extra-large oven window for greater visibility when cooking.

## LP Convertible

Can be converted from natural gas to a liquid petroleum fuel source.

## Max Capacity recessed rack

Makes room for large items and helps keep food in place while baking.

## Melt/Soften cycles

Gently melts foods such as chocolate without cooking (Melt Cycle); gently softens food such as butter without melting (Soften Cycle).

## Microwave steamer

Works in tandem with the steaming function to conveniently steam foods such as rice, vegetables and fish with fresh, pleasing results.

## Modular cooktop

Allows you to customize the cooking surface according to your needs with gas burners, grill modules and griddle modules.

## Most Used cycle

Saves time by remembering and activating your most frequently used Velos® SpeedCook cycle with the simple press of a button.

## No Drip chrome drip bowl

Keeps cooking cleanup to a minimum and keeps spills from getting under the cooking surface.

††Glass cooktop surface manufactured without the release of hazardous metals into the earth.  
‡Available on 27" and 30" double and single wall ovens. See product specifications for minimum and maximum installation dimensions.

# Glossary

## One touch bake and broil

Automatically sets the oven to 350°F when the “Bake” button is pushed and 500°F when the “Broil” button is selected.

## Oval burner

An elongated central burner that can match oval-shaped pans and other longer cookware. Ideal for cooking oversized dishes on the range top.

## Oven Hold Warm/Warm Hold/Keep Warm

Uses low heat to keep food warm inside the oven or microwave, so you can keep completed dishes from getting cold while you work on the rest of your meal.

## Pop-up downdraft vent

Variable fan speeds make adjusting the ventilation easy for every situation. Retracts when not in use.

## Power™ burners

Generate the high heat needed for rapid boiling, searing and frying with burners that offer up to 17,000 BTUs.

## Power “On” indicator

Provides an illuminated reminder that the cooktop is turned on.

## Precise Clean® system

Tracks how long it has been since the last self-cleaning cycle and suggests just the right cycle time, so the self-cleaning cycle only lasts as long as necessary for optimal cleaning. No harsh chemicals or cleaners are required.

## Preheat countdown timer

Keeps track of how long the oven will take to reach the desired baking temperature with a display that counts down the required time or temperature.

## Rapid Boil element

Create your everyday favorite dishes with a flexible cooking element that has the power to take your dishes from an accurate simmer to a rolling boil.

## Rapid Preheat option

Preheat the oven 25% faster\* with Rapid Preheat. Ideal for single rack baking, this option saves cooking time and energy.

## Recessed cooktop

Provides a more aesthetically pleasing profile by lowering the level of the grates.

## Sabbath Mode

Overrides the oven’s automatic shut-off function, keeping it active for hours of uninterrupted cooking, making it possible to use the oven on the Sabbath without turning it on.

## Sealed burners

Cleans up quickly after cooking is complete. No gap between the cooktop and these burners makes for a smooth surface that’s easy to clean.

## Self-cleaning system (traditional)

Automatically cleans the oven according to a preprogrammed cycle. No harsh chemicals or cleaners are required.

## Sensor cooking

Tracks the progress of your food and automatically adjusts the cooking time as needed to deliver optimal results

## SpeedCook technology

Cuts cooking time by up to 47% compared to traditional ovens. Microwave technology works with halogen and quartz light energy to grill steaks and bake brownies with real oven results.

## SpillGuard™ cooktop

Helps contain messes and makes cleanup easier with the raised-edge design.

## Split rack

Remove the rack insert to make room for large or tall items, or attach it to make a full rack.

## Staged cooking

Allows you to custom program multiple power levels and cooking durations without keeping watch over the microwave. Ideal for dishes requiring temperature changes mid-cooking, like frozen entrees.

## SteamClean option

Clean up every day light spills using heat and only 1-1/4 cups of water—no harsh chemicals or cleaners needed.

## Steam cooking

Conveniently steams foods such as rice, vegetables and fish in conjunction with the patented microwave steamer.

## Tap Touch controls

Provide a sleek, sophisticated look that is easy to clean. Cooktop controls can be set with a simple touch.

## TimeSavor™ convection

Uses a fan in the back of the oven to distribute hot air more efficiently for crispier, juicier and tastier results.

---

\*Single rack baking with Rapid Preheat option versus three-rack without option.

# Glossary

## **TimeSavor™ Plus true convection**

Uses a fan plus a third heating element in the oven or microwave to distribute hot air more efficiently and seal in flavor and juices on every rack. Select microwaves use a rear fan to also cut roasting time compared to traditional thermal-bake ovens.

## **TimeSavor™ Ultra true convection**

TimeSavor™ Ultra true convection uses a rear fan, a third 2,500-watt heating element and an innovative X-shaped baffle to distribute heated air more efficiently in four directions.

## **Touch screen controls**

Features dozens of step-by-step directions on a digital display for simple, accurate cooking in the microwave.

## **TruCapture® ventilation system**

Removes cooktop smoke, steam and odors from the front two burners with a powerful 4-speed fan and unique, sloped design that vents out the top instead of the front of the unit. Whirlpool brand's most efficient ventilation system.

## **Velos® SpeedCook oven**

Microwave hood combination oven that grills, bakes, steams, microwaves and vents, featuring SpeedCook technology as well as the TruCapture® ventilation system.

## **Warming drawer**

Keeps food and dinnerware warm in a separate, heated drawer. Multiple temperature settings provide flexibility and help ensure that food done ahead of schedule doesn't get cold before the entire meal is ready to serve.

## **Warm Zone element**

Prevents food from cooling while the rest of the meal is being prepared. This low-powered (20–100 watt) fifth element provides added flexibility and convenience.

## **Washable filter**

Dishwasher-safe filters trap unwanted grease and odors and wash easily for re-use.



# Freestanding Double Oven Electric Ranges

## SPECIFICATIONS AND DIMENSIONS

| MODEL  | WHIRLPOOL®             |                        | WHIRLPOOL GOLD®        |                        |
|--|------------------------|------------------------|------------------------|------------------------|
|  | WGE555S0B              | WGE755C0B              | WGI925C0B              | INDUCTION              |
| <b>New 2013 model</b>                            | -                      | -                      | -                      | -                      |
| Oven capacity (cu. ft.)                          | 2.5 Upper<br>4.2 Lower | 2.5 Upper<br>4.2 Lower | 2.5 Upper<br>4.2 Lower | 2.5 Upper<br>4.2 Lower |
| Total capacity (cu. ft.)                         | 6.7                    | 6.7                    | 6.7                    | 6.7                    |
| Recommended MHC                                  | WMH53520A              | WMH53520A              | WMH53520A              | WMH75520A              |
| Electronic oven controls                         | -                      | -                      | -                      | -                      |
| Designed, engineered and assembled in the U.S.A. | -                      | -                      | -                      | -                      |
| <b>CONVENIENCE FEATURES (BOTH OVENS)</b>         |                        |                        |                        |                        |
| AccuBake® temperature management system          | -                      | -                      | -                      | -                      |
| Precise Clean™ self-cleaning system              | -                      | -                      | -                      | -                      |
| SteamClean option                                | -                      | ◆                      | -                      | -                      |
| Hidden bake element                              | -                      | ◆                      | -                      | -                      |
| Rapid Preheat (default)                          | -                      | -                      | -                      | -                      |
| Delay Bake                                       | -                      | -                      | -                      | -                      |
| Broil  | -                      | -                      | -                      | -                      |
| Keep Warm  | -                      | -                      | -                      | -                      |
| Sabbath Mode                                     | -                      | -                      | -                      | -                      |
| Control lock                                     | -                      | -                      | -                      | -                      |
| Clock and timer display color                    | Blue                   | Blue                   | Blue                   | Blue                   |
| Automatic oven light                             | -                      | -                      | -                      | -                      |
| <b>UPPER OVEN FEATURES</b>                       |                        |                        |                        |                        |
| Adjustable rack                                  | 1                      | 1                      | 1                      | 1                      |
| Rack positions                                   | 2                      | 2                      | 2                      | 2                      |
| Large oven window                                | -                      | -                      | -                      | -                      |
| <b>LOWER OVEN FEATURES</b>                       |                        |                        |                        |                        |
| TimeSavor™ Plus true convection                  | -                      | ◆                      | -                      | -                      |
| TimeSavor™ convection                            | -                      | -                      | -                      | -                      |
| Adjustable racks                                 | 2                      | 2                      | 2                      | 2                      |
| Rack positions                                   | 5                      | 5                      | 5                      | 5                      |
| EasyView™ extra-large oven window                | -                      | -                      | -                      | -                      |
| <b>COOKTOP FEATURES</b>                          |                        |                        |                        |                        |
| AccuHeat™ induction technology                   | -                      | -                      | ◆                      | -                      |
| Ceramic glass cooktop                            | Eco-friendly*          | Eco-friendly*          | -                      | -                      |
| Upswept SpillGuard™ cooktop                      | -                      | -                      | -                      | -                      |
| Element type                                     | Radiant                | Radiant                | <b>Induction</b>       |                        |
| Left rear element                                | 6" Melt                | 6" Melt                | <b>11" Boost</b>       |                        |
| Right rear element                               | 6"                     | 6"                     | <b>6" Boost</b>        |                        |
| Left front element                               | 9"/6" dual             | <b>12"/6" dual</b>     | <b>6" Boost</b>        |                        |
| Right front element                              | 10"                    | <b>10" Rapid Boil</b>  | <b>7" Boost</b>        |                        |
| Center element                                   | 6.7" Warm Zone         | 6.7" Warm Zone         | -                      |                        |
| <b>DIMENSIONS AND COLORS</b>                     |                        |                        |                        |                        |
| Cutout height (A)                                | 36"                    | 36"                    | 36"                    |                        |
| Cutout width (B)                                 | 30 1/8"                | 30 1/8"                | 30 1/8"                |                        |
| Cutout depth (C)                                 | 24"                    | 24"                    | 24"                    |                        |
| Overall height (D)                               | 47 1/4"                | 47 1/4"                | 47 1/4"                |                        |
| Height to maintop (E)                            | 35 1/4"                | 35 1/4"                | 35 1/4"                |                        |
| Overall width (F)                                | 29 3/8"                | 29 3/8"                | 29 3/8"                |                        |
| Depth without handle (G)                         | 27 1/4"                | 27 1/4"                | 27 1/4"                |                        |
| Depth with handle                                | 28 1/2"                | 28 1/2"                | 28 1/2"                |                        |
| Depth with door open 90°                         | 46"                    | 46"                    | 46"                    |                        |
| Available colors                                 | W   B   S              | S   H   E              | S                      |                        |

Bold type indicates a step-up feature

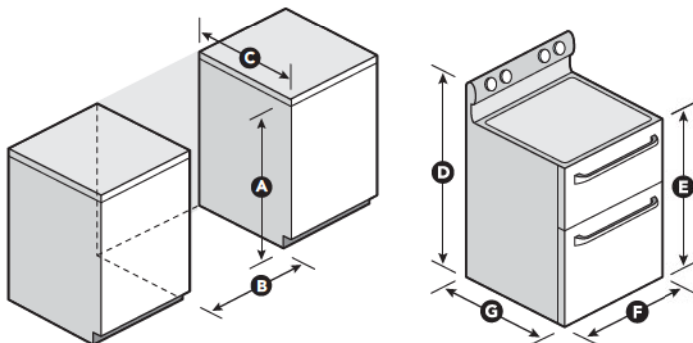

\*Glass cooktop surface manufactured without the release of hazardous metals into the earth.

DIMENSIONS ARE SHOWN FOR PLANNING PURPOSES ONLY.  
For complete information, see Installation Instructions packed with product.

# Freestanding Double Oven Gas Ranges

## SPECIFICATIONS AND DIMENSIONS

|  | WHIRLPOOL®                        | WHIRLPOOL GOLD®                   |
|--|-----------------------------------|-----------------------------------|
| MODEL  | WGG55S0B                          | WGG75S0B                          |
| <b>New 2013 model</b>                            | -                                 | -                                 |
| Oven capacity (cu. ft.)                          | 2.1 Upper<br>3.9 Lower            | 2.1 Upper<br>3.9 Lower            |
| Total capacity (cu. ft.)                         | 6.0                               | 6.0                               |
| Recommended MHC                                  | WMH53520A                         | WMH53520A                         |
| Electronic oven controls                         | -                                 | -                                 |
| Designed, engineered and assembled in the U.S.A. | -                                 | -                                 |
| <b>CONVENIENCE FEATURES (BOTH OVENS)</b>         |                                   |                                   |
| AccuBake® temperature management system          | -                                 | -                                 |
| Precise Clean™ self-cleaning system              | -                                 | -                                 |
| Hidden bake element                              | -                                 | -                                 |
| Delay Bake                                       | -                                 | -                                 |
| Keep Warm  | -                                 | -                                 |
| Sabbath Mode                                     | -                                 | -                                 |
| Control lock                                     | -                                 | -                                 |
| Clock and timer display color                    | Blue                              | Blue                              |
| Automatic oven light                             | -                                 | -                                 |
| LP Convertible                                   | -                                 | -                                 |
| <b>UPPER OVEN FEATURES</b>                       |                                   |                                   |
| Broil  | -                                 | -                                 |
| Adjustable rack                                  | 1                                 | 1                                 |
| Rack positions                                   | 2                                 | 2                                 |
| Large oven window                                | -                                 | -                                 |
| <b>LOWER OVEN FEATURES</b>                       |                                   |                                   |
| TimeSaver™ convection                            | -                                 | ♦                                 |
| Adjustable racks                                 | 2                                 | 2                                 |
| Rack positions                                   | 5                                 | 5                                 |
| EasyView™ extra-large oven window                | -                                 | -                                 |
| <b>COOKTOP FEATURES</b>                          |                                   |                                   |
| Full-width, satin-finish cast-iron grates        | -                                 | -                                 |
| Left rear element/burner                         | 5,000 BTU AccuSimmer®             | 5,000 BTU AccuSimmer®             |
| Right rear element/burner                        | 9,200 BTU                         | <b>5,000 BTU AccuSimmer®</b>      |
| Left front element/burner                        | 15,000 BTU Power™                 | <b>16,000 BTU Power™</b>          |
| Right front element/burner                       | 9,200 BTU                         | <b>10,000 BTU</b>                 |
| Center element/burner                            | -                                 | <b>7,350 BTU Oval</b>             |
| <b>DIMENSIONS AND COLORS</b>                     |                                   |                                   |
| Cutout height (A)                                | 36"                               | 36"                               |
| Cutout width (B)                                 | 30 <sup>1</sup> / <sub>4</sub> "  | 30 <sup>1</sup> / <sub>4</sub> "  |
| Cutout depth (C)                                 | 24"                               | 24"                               |
| Overall height (D)                               | 47 <sup>1</sup> / <sub>4</sub> "  | 47 <sup>1</sup> / <sub>4</sub> "  |
| Height to maintop (E)                            | 35 <sup>1</sup> / <sub>2</sub> "  | 35 <sup>1</sup> / <sub>2</sub> "  |
| Overall width (F)                                | 29 <sup>9</sup> / <sub>16</sub> " | 29 <sup>9</sup> / <sub>16</sub> " |
| Depth without handle (G)                         | 27 <sup>1</sup> / <sub>2</sub> "  | 27 <sup>1</sup> / <sub>2</sub> "  |
| Depth with handle                                | 28 <sup>1</sup> / <sub>2</sub> "  | 28 <sup>1</sup> / <sub>2</sub> "  |
| Depth with door open 90°                         | 46"                               | 46"                               |
| Available colors                                 | W   B   S                         | S   H   E                         |

Bold type indicates a step-up feature

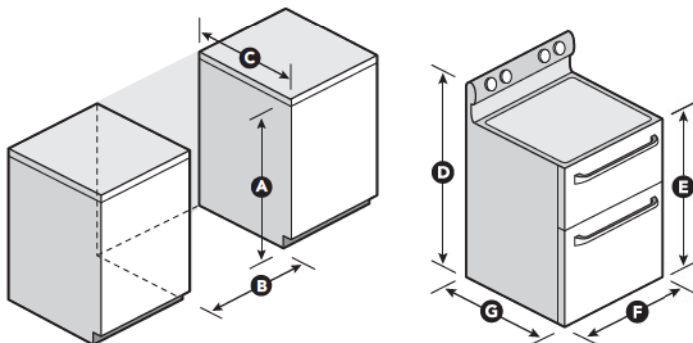

DIMENSIONS ARE SHOWN FOR PLANNING PURPOSES ONLY.  
For complete information, see Installation Instructions packed with product.



# Freestanding Electric Ranges

## SPECIFICATIONS AND DIMENSIONS

| WHIRLPOOL®                                       |               |               |                                 |                              |
|--|---------------|---------------|---------------------------------|------------------------------|
| MODEL  | WFC130M0A     | WFC340S0A     | WFC310S0A                       | WFE320M0A                    |
| Capacity (cu. ft.)                               | 4.8           | 4.8           | 4.8                             | 4.8                          |
| Recommended MHC                                  | WMH31017A     | WMH31017A     | WMH31017A                       | WMH31017A                    |
| Oven controls                                    | Electronic    | Knob          | <b>Electronic</b>               | Electronic                   |
| Metal handle*                                    |               | ♦             |                                 | ♦                            |
| ADA compliant**                                  |               | ♦             |                                 |                              |
| Designed, engineered and assembled in the U.S.A. | -             | -             | -                               | -                            |
| <b>OVEN FEATURES</b>                             |               |               |                                 |                              |
| AccuBake® temperature management system          |               |               | ♦                               |                              |
| Traditional self-cleaning system                 |               | ♦             | -                               |                              |
| Delay Bake                                       |               |               | ♦                               |                              |
| Keep Warm  |               |               | ♦                               |                              |
| Custom Broil                                     | -             | -             | -                               | -                            |
| Sabbath Mode                                     | -             |               | ♦                               |                              |
| Control lock                                     | -             |               | ♦                               | -                            |
| Clock and timer display color                    | Blue          |               | <b>Blue</b>                     | Blue                         |
| Oven light                                       | -             | -             | -                               | -                            |
| Total adjustable racks                           | 2             | 2             | 2                               | 2                            |
| Oven window                                      | Standard      | <b>Large</b>  | Large                           | Large                        |
| Lower drawer                                     | Storage       | Storage       | Storage                         | Storage                      |
| <b>COOKTOP FEATURES</b>                          |               |               |                                 |                              |
| Eco-friendly ceramic glass cooktop†              |               |               |                                 | ♦                            |
| Upswept porcelain SpillGuard™ cooktop            | -             | -             | -                               |                              |
| Element type                                     | Coil          | Coil          | <b>High-speed coils</b>         | <b>Radiant</b>               |
| Left rear element                                | 6" 1,250-watt | 6" 1,250-watt | <b>6" 1,500-watt high speed</b> | 6" 1,200-watt                |
| Right rear element                               | 8" 2,100-watt | 8" 2,100-watt | <b>8" 2,600-watt high speed</b> | 6" 1,200-watt                |
| Left front element                               | 8" 2,100-watt | 8" 2,100-watt | <b>8" 2,600-watt high speed</b> | <b>9"/6" 3,000-watt dual</b> |
| Right front element                              | 6" 1,250-watt | 6" 1,250-watt | <b>6" 1,500-watt high speed</b> | <b>9" 2,500-watt</b>         |
| <b>DIMENSIONS AND COLORS</b>                     |               |               |                                 |                              |
| Cutout height (A)                                | 36"           | 36"           | 36"                             | 36"                          |
| Cutout width (B)                                 | 30"           | 30"           | 30"                             | 30"                          |
| Cutout depth (C)                                 | 24"           | 24"           | 24"                             | 24"                          |
| Overall height (D)                               | 46 1/8"       | 46 1/8"       | 46 1/8"                         | 46 1/8"                      |
| Height to maintop (E)                            | 36"           | 36"           | 36"                             | 36"                          |
| Overall width (F)                                | 29 1/8"       | 29 1/8"       | 29 1/8"                         | 29 1/8"                      |
| Overall depth (G)                                | 27 3/4"       | 27 3/4"       | 27 3/4"                         | 27 3/4"                      |
| Depth without handle                             | 25 1/8"       | 25 1/8"       | 25 1/8"                         | 25 1/8"                      |
| Depth with door open 90°                         | 46 1/8"       | 46 1/8"       | 46 1/8"                         | 46 1/8"                      |
| Available colors                                 | W   B         | W   B   S     | W   B   S                       | W   B   S                    |

Bold type indicates a step-up feature

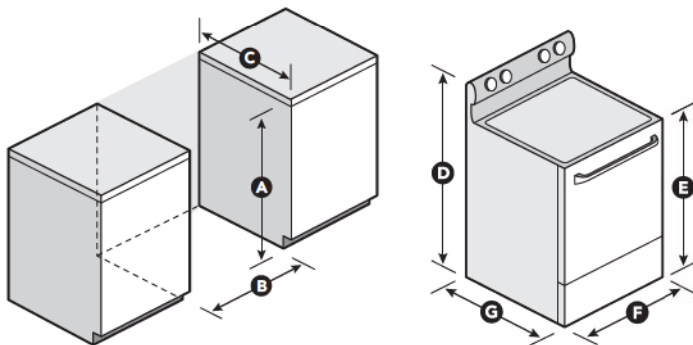

\*Available on Stainless Steel models only. \*\*Model meets applicable ADA requirements and must be installed in compliance with the current ADA Standards. †Glass cooktop surface manufactured without the release of hazardous metals into the earth.

DIMENSIONS ARE SHOWN FOR PLANNING PURPOSES ONLY.  
For complete information, see Installation Instructions packed with product.

# Freestanding Electric Ranges

## SPECIFICATIONS AND DIMENSIONS

| MODEL  | WHIRLPOOL®               |                                  | WHIRLPOOL GOLD®                      |  |                                  |
|--|--------------------------|----------------------------------|--------------------------------------|--|----------------------------------|
|  | WFE510S0A                | WFE540H0A                        | WFE710H0A                            | WFE720H0A                              | WFI910H0A INDUCTION              |
| Capacity (cu. ft.)                               | 4.8                      | 6.2                              | 6.2                                  | 6.2                                    | 6.2                              |
| Recommended MHC                                  | WMH32517A                | WMH53520A                        | WMH53520A                            | WMH53520A                              | WMH53520A                        |
| Oven controls                                    | Electronic               | Electronic                       | Electronic                           | Electronic                             | Tap Touch††                      |
| Metal handle*                                    | -                        | -                                | -                                    | -                                      | -                                |
| Designed, engineered and assembled in the U.S.A. | -                        | -                                | -                                    | -                                      | -                                |
| <b>OVEN FEATURES</b>                             |                          |                                  |                                      |  |                                  |
| AccuBake® temperature management system          | ♦                        | -                                | -                                    | -                                      | -                                |
| AquaLift® self-clean technology                  | -                        | ♦                                | -                                    | -                                      | -                                |
| Traditional self-cleaning system                 | ♦                        | -                                | -                                    | -                                      | -                                |
| Hidden bake element                              | -                        | with thermal vents               | with thermal vents                   | with thermal vents                     | with thermal vents               |
| TimeSavor™ Plus true convection                  | -                        | -                                | ♦                                    | -                                      | -                                |
| TimeSavor™ convection                            | -                        | ♦                                | -                                    | -                                      | -                                |
| Convection Conversion                            | -                        | -                                | ♦                                    | -                                      | -                                |
| Energy Save mode                                 | -                        | ♦                                | -                                    | -                                      | -                                |
| Rapid Preheat                                    | -                        | -                                | ♦                                    | -                                      | -                                |
| Delay Bake                                       | -                        | ♦                                | -                                    | -                                      | -                                |
| Keep Warm  | -                        | ♦                                | -                                    | -                                      | -                                |
| Custom Broil                                     | -                        | -                                | -                                    | -                                      | -                                |
| Sabbath Mode                                     | -                        | -                                | -                                    | -                                      | -                                |
| Control lock                                     | -                        | -                                | -                                    | -                                      | -                                |
| Clock and timer display color                    | Blue                     | Blue                             | Blue                                 | Blue                                   | Blue                             |
| Oven light                                       | -                        | -                                | -                                    | -                                      | -                                |
| Total adjustable racks                           | 2                        | 2                                | 3                                    | 3                                      | 3                                |
| Max Capacity recessed rack                       | -                        | ♦                                | -                                    | -                                      | -                                |
| Adjustable split rack                            | -                        | -                                | ♦                                    | -                                      | -                                |
| Oven window                                      | Large                    | EasyView™ extra-large            | EasyView™ extra-large                | EasyView™ extra-large                  | EasyView™ extra-large            |
| Lower drawer                                     | Storage                  | Storage                          | Storage                              | High/Med/Low warming with handle       | High/Med/Low warming with handle |
| <b>COOKTOP FEATURES</b>                          |                          |                                  |                                      |  |                                  |
| AccuHeat™ induction technology                   | -                        | -                                | -                                    | -                                      | ♦                                |
| Ceramic glass cooktop                            | Eco-friendly†            | Eco-friendly†                    | Eco-friendly†                        | Eco-friendly†                          | -                                |
| Element type                                     | Radiant                  | Radiant                          | Radiant                              | Radiant                                | Induction                        |
| Left rear element                                | 6" 1,200-watt            | 6" 1,200-watt                    | <b>6" 300/1,300-watt AccuSimmer®</b> | 6" 300/1,300-watt AccuSimmer®          | <b>9" 3,200-watt Boost</b>       |
| Right rear element                               | 6" 1,200-watt            | 6" 1,200-watt                    | 6" 1,200-watt                        | 6" 1,200-watt                          | <b>11" 3,700-watt Boost</b>      |
| Left front element                               | 9"/6"<br>3,000-watt dual | 12"/9"<br>3,000-watt dual        | 12"/9"<br>3,000-watt dual            | <b>12"/9"/6"<br/>3,000-watt triple</b> | <b>6"<br/>1,800-watt Boost</b>   |
| Right front element                              | 9" 2,500-watt            | <b>9"/6"<br/>3,000-watt dual</b> | 9"/6"<br>3,000-watt dual             | <b>10"<br/>3,200-watt Rapid Boil</b>   | <b>6"<br/>1,800-watt Boost</b>   |
| Center rear element                              | -                        | 6" 100-watt Warm Zone            | 6" 100-watt Warm Zone                | 6" 100-watt Warm Zone                  | -                                |
| <b>DIMENSIONS AND COLORS</b>                     |                          |                                  |                                      |  |                                  |
| Cutout height (A)                                | 36"                      | 36"                              | 36"                                  | 36"                                    | 36"                              |
| Cutout width (B)                                 | 30"                      | 30"                              | 30"                                  | 30"                                    | 30"                              |
| Cutout depth (C)                                 | 24"                      | 24"                              | 24"                                  | 24"                                    | 24"                              |
| Overall height (D)                               | 46 1/8"                  | 46 1/8"                          | 46 1/8"                              | 46 1/8"                                | 46 1/8"                          |
| Height to maintop (E)                            | 36"                      | 36"                              | 36"                                  | 36"                                    | 36"                              |
| Overall width (F)                                | 29 1/8"                  | 29 1/8"                          | 29 1/8"                              | 29 1/8"                                | 29 1/8"                          |
| Overall depth (G)                                | 27 1/4"                  | 27 1/4"                          | 27 1/4"                              | 27 1/4"                                | 27 1/4"                          |
| Depth without handle                             | 25 1/8"                  | 25 1/8"                          | 25 1/8"                              | 25 1/8"                                | 25 1/8"                          |
| Depth with door open 90°                         | 46 1/8"                  | 47 3/8"                          | 47 3/8"                              | 47 3/8"                                | 47 3/8"                          |
| Available colors                                 | W   B   T   D   S        | W   B   S   H   E                | S   H   E                            | S                                      | S                                |

Bold type indicates a step-up feature

\*Available on Stainless Steel models only. †Glass cooktop surface manufactured without the release of hazardous metals into the earth. ††Cooktop only.

DIMENSIONS ARE SHOWN FOR PLANNING PURPOSES ONLY.  
For complete information, see Installation Instructions packed with product.

# Freestanding Gas Ranges

## SPECIFICATIONS AND DIMENSIONS

| MODEL  | WHIRLPOOL® |                |                         |                                     |                                     | WHIRLPOOL GOLD®                     |                                     |
|--|------------|----------------|-------------------------|-------------------------------------|-------------------------------------|-------------------------------------|-------------------------------------|
|  | WFG114SW   | WFG231LV       | WFG510S0A               | WFG520S0A                           | WFG540H0A                           | WFG710H0A                           | WFG720H0A                           |
| Capacity (cu. ft.)                               | 4.4        | 4.4            | 5.0                     | 5.0                                 | 5.8                                 | 5.8                                 | 5.8                                 |
| Recommended MHC                                  | WMH31017A  | WMH31017A      | WMH32517A               | WMH53520A                           | WMH53520A                           | WMH53520A                           | WMH53520A                           |
| Oven controls                                    | Electronic | Electronic     | Electronic              | Electronic                          | Electronic                          | Electronic                          | Electronic                          |
| Metal handle*                                    |            |                | ♦                       | -                                   | -                                   | -                                   | -                                   |
| Designed, engineered and assembled in the U.S.A. |            |                | ♦                       | -                                   | -                                   | -                                   | -                                   |
| <b>OVEN FEATURES</b>                             |            |                |                         |                                     |                                     |                                     |                                     |
| AccuBake® temperature management system          |            |                | ♦                       | -                                   | -                                   | -                                   | -                                   |
| AquaLift® self-clean technology                  |            |                |                         |                                     | ♦                                   | -                                   | -                                   |
| Traditional self-cleaning system                 |            |                | ♦                       | -                                   | -                                   | -                                   | -                                   |
| TimeSaver™ Plus true convection                  |            |                |                         |                                     |                                     |                                     | ♦                                   |
| TimeSaver™ convection                            |            |                |                         |                                     | ♦                                   | -                                   | -                                   |
| Convection Conversion                            |            |                |                         |                                     |                                     | ♦                                   | -                                   |
| Energy Save                                      |            |                |                         |                                     | ♦                                   | -                                   | -                                   |
| Rapid Preheat                                    |            |                |                         |                                     |                                     | ♦                                   | -                                   |
| Delay Bake                                       |            |                | ♦                       | -                                   | -                                   | -                                   | -                                   |
| Keep Warm  |            |                | ♦                       | -                                   | -                                   | -                                   | -                                   |
| Custom Broil                                     |            |                | -                       | -                                   | -                                   | -                                   | -                                   |
| Sabbath Mode                                     |            |                | ♦                       | -                                   | -                                   | -                                   | -                                   |
| Control lock                                     |            |                | ♦                       | -                                   | -                                   | -                                   | -                                   |
| Clock and timer display color                    | Blue green | Blue green     | Blue                    | Blue                                | Blue                                | Blue                                | Blue                                |
| Oven light                                       | -          | -              | -                       | -                                   | -                                   | -                                   | -                                   |
| Total adjustable racks                           | 2          | 2              | 2                       | 2                                   | 2                                   | 3                                   | 3                                   |
| Max Capacity recessed rack                       |            |                |                         |                                     | ♦                                   | -                                   | -                                   |
| Adjustable split rack                            |            |                |                         |                                     |                                     | ♦                                   | -                                   |
| Oven window                                      | Standard   | Large          | Large                   | Large                               | EasyView™ extra-large               | EasyView™ extra-large               | EasyView™ extra-large               |
| Lower drawer                                     | Broiler    | Broiler        | Storage                 | Storage                             | Storage                             | Storage                             | High/Med/Low warming with handle    |
| LP Convertible (kit included)                    | -          | -              | -                       | -                                   | -                                   | -                                   | -                                   |
| <b>COOKTOP FEATURES</b>                          |            |                |                         |                                     |                                     |                                     |                                     |
| Included griddle                                 |            | Center         |                         |                                     |                                     | Side integrated                     | Side integrated                     |
| Recessed cooktop                                 |            |                | ♦                       | -                                   | -                                   | -                                   | -                                   |
| Burner grates                                    | Cast-iron  | Cast-iron      | Satin-finish, cast-iron | Full-width, satin-finish, cast-iron | Full-width, satin-finish, cast-iron | Full-width, satin-finish, cast-iron | Full-width, satin-finish, cast-iron |
| Left rear burner                                 | 9,500 BTU  | 7,000 BTU      | 9,500 BTU               | 9,500 BTU                           | 9,500 BTU                           | 9,500 BTU                           | 9,500 BTU                           |
| Right rear burner                                | 9,500 BTU  | 7,000 BTU      | 5,000 BTU AccuSimmer®   | 5,000 BTU AccuSimmer®               | 5,000 BTU AccuSimmer®               | 5,000 BTU AccuSimmer®               | 5,000 BTU AccuSimmer®               |
| Left front burner                                | 11,500 BTU | 8,000 BTU      | 13,500 BTU Power™       | 15,000 BTU Power™                   | 17,000 BTU Power™                   | 17,000 BTU Power™                   | 17,000 BTU Power™                   |
| Right front burner                               | 9,500 BTU  | 7,000 BTU      | 9,500 BTU               | 15,000 BTU Power™                   | 15,000 BTU Power™                   | 15,000 BTU Power™                   | 15,000 BTU Power™                   |
| Center burner                                    |            | 7,500 BTU Oval |                         |                                     | 8,000 BTU Middle                    | 8,000 BTU Middle                    | 8,000 BTU Middle                    |
| <b>DIMENSIONS AND COLORS</b>                     |            |                |                         |                                     |                                     |                                     |                                     |
| Cutout height (A)                                | 36"        | 36"            | 36"                     | 36"                                 | 36"                                 | 36"                                 | 36"                                 |
| Cutout width (B)                                 | 30"        | 30"            | 30"                     | 30"                                 | 30"                                 | 30"                                 | 30"                                 |
| Cutout depth (C)                                 | 24"        | 24"            | 24"                     | 24"                                 | 24"                                 | 24"                                 | 24"                                 |
| Overall height (D)                               | 46 1/4"    | 46 1/4"        | 46 1/4"                 | 46 1/4"                             | 46 1/4"                             | 46 1/4"                             | 46 1/4"                             |
| Height to maintop (E)                            | 36"        | 36"            | 36"                     | 36"                                 | 36"                                 | 36"                                 | 36"                                 |
| Overall width (F)                                | 29 1/8"    | 29 1/8"        | 29 1/8"                 | 29 1/8"                             | 29 1/8"                             | 29 1/8"                             | 29 1/8"                             |
| Overall depth (G)                                | 26 3/4"    | 25 3/4"        | 27 1/4"                 | 27 1/4"                             | 27 1/4"                             | 27 1/4"                             | 27 1/4"                             |
| Depth without handle                             | 24 1/4"    | 24 1/4"        | 25 1/8"                 | 25 1/8"                             | 25 1/8"                             | 25 1/8"                             | 25 1/8"                             |
| Depth with door open 90°                         | 42 1/8"    | 42 1/8"        | 46 1/8"                 | 46 1/8"                             | 47 1/8"                             | 47 1/8"                             | 47 1/8"                             |
| Available colors                                 | Q   B      | Q   B   S      | W   B   T   D   S       | W   B   S                           | W   B   S   H   E                   | S   H   E                           | S                                   |

Bold type indicates a step-up feature

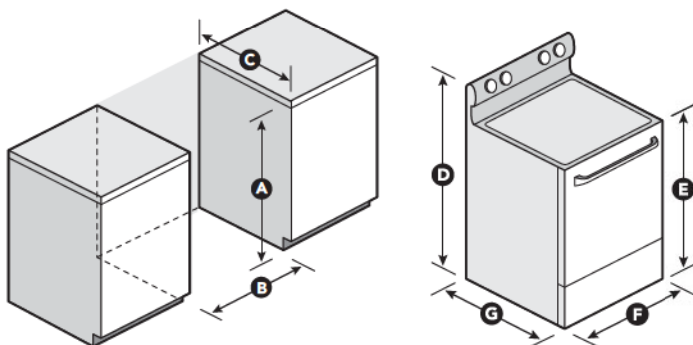

\*Available on Stainless Steel models only.

DIMENSIONS ARE SHOWN FOR PLANNING PURPOSES ONLY.  
For complete information, see Installation Instructions packed with product.

# Slide-In Ranges

## SPECIFICATIONS AND DIMENSIONS

| MODEL  | WHIRLPOOL®  |   | WHIRLPOOL GOLD®                                   |   |   |
|--|---|---|---|---|---|
|  | RY160LXT<br>ELECTRIC                              | GY397LXU<br>ELECTRIC                              | GY399LXU<br>ELECTRIC                              | GW397LXU<br>GAS                                   | GW399LXU<br>GAS                                   |
| Capacity (cu. ft.)                               | 4.3   | 4.5   | 4.5   | 4.5   | 4.5   |
| Recommended MHC                                  | WMH3205XV   | WMH75520A   | WMH76718A   | WMH75520A   | WMH76718A   |
| Metal handle*                                    |   | ♦   | -   | -   | -   |
| ADA compliant**                                  |   |   |   |   |   |
| Designed, engineered and assembled in the U.S.A. | -   | -   | -   | -   | -   |
| <b>OVEN FEATURES</b>                             |   |   |   |   |   |
| AccuBake® temperature management system          |   | ♦   | -   | -   | -   |
| Precise Clean™ self-cleaning system              | -   | -   | -   | -   | -   |
| Hidden bake element                              |   |   | ♦   | -   | -   |
| TimeSaver™ Plus true convection                  |   |   | ♦   |   | ♦   |
| Delay Bake                                       |   | ♦   | -   | -   | -   |
| Warm Hold  | -   | -   | -   | -   | -   |
| Sabbath Mode                                     | -   | -   | -   | -   | -   |
| Control lock                                     | -   | -   | -   | -   | -   |
| Clock and timer display color                    | Blue  | Blue  | Blue  | Blue  | Blue  |
| Automatic oven light                             |   | ♦   | -   | -   | -   |
| Raised ergonomic console                         |   | ♦   | -   | -   | -   |
| Total adjustable racks                           | 2   | 2   | 2   | 2   | 2   |
| Adjustable split rack                            |   |   | ♦   |   | ♦   |
| Extra-large oven window                          | -   | -   | -   | -   | -   |
| Storage drawer                                   | -   | -   | -   | -   | -   |
| Frameless door design                            |   | ♦   | -   | -   | -   |
| LP Convertible                                   |   |   |   | -   | -   |
| <b>COOKTOP FEATURES</b>                          |   |   |   |   |   |
| Eco-friendly ceramic glass cooktop†              |   | ♦   | -   | -   | -   |
| Recessed cooktop                                 |   |   |   | -   | -   |
| Element type                                     | Coil  | <b>Radiant</b>                                    | Radiant   |   |   |
| Continuous, satin-finish, cast-iron grates       |   |   |   | -   | -   |
| Left rear element/burner                         | 8"  | <b>9"/6" dual</b>                                 | 9"/6" dual  | 5,000 BTU   | 5,000 BTU   |
| Right rear element/burner                        | 6"  | 6"  | 6"  | 9,200 BTU   | 9,200 BTU   |
| Left front element/burner                        | 6"  | 6"  | 6"  | 9,200 BTU   | <b>12,500 BTU Power™</b>                          |
| Right front element/burner                       | 8"  | <b>9"/6" dual</b>                                 | <b>12"/9" dual</b>                                | 14,000 BTU Power™                                 | <b>16,000 BTU Power™</b>                          |
| <b>ACCESSORIES</b>                               |   |   |   |   |   |
| Filler Strip                                     | W10113931 (Q)<br>W10113902A (B)<br>W10113901A (S) | W10113931 (Q)<br>W10113902A (B)<br>W10113901A (S) | W10113931 (Q)<br>W10113902A (B)<br>W10113901A (S) | W10113931 (Q)<br>W10113902A (B)<br>W10113901A (S) | W10113931 (Q)<br>W10113902A (B)<br>W10113901A (S) |
| <b>DIMENSIONS AND COLORS</b>                     |   |   |   |   |   |
| Cutout width (A)                                 | 30"   | 30"   | 30"   | 30"   | 30"   |
| Cutout depth (B)                                 | 23 1/4"   | 23 1/4"   | 23 1/4"   | 23 1/4"   | 23 1/4"   |
| Height (C)                                       | 35 1/4"   | 35 1/4"   | 35 1/4"   | 35 1/4"   | 35 1/4"   |
| Base width (D)                                   | 29 1/8"   | 29 1/8"   | 29 1/8"   | 29 1/8"   | 29 1/8"   |
| Depth (E)  | 28 1/8"   | 28 1/4"   | 28 1/4"   | 28 1/4"   | 28 1/4"   |
| Available colors                                 | Q   B   S   | Q   B   S   | Q   B   S   | Q   B   S   | Q   B   S   |

Bold type indicates a step-up feature

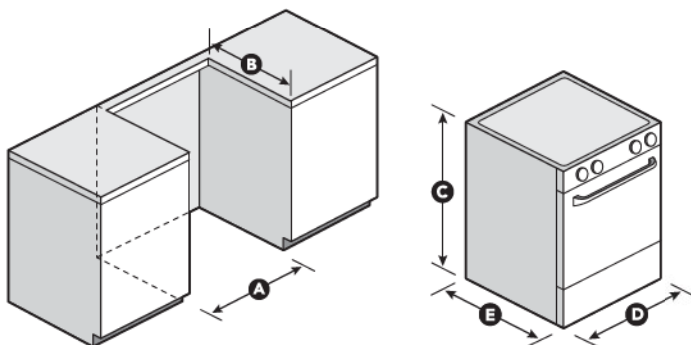

\*Available on Stainless Steel models only. \*\*Model meets applicable ADA requirements and must be installed in compliance with the current ADA Standards.  
†Glass cooktop surface manufactured without the release of hazardous metals into the earth.

DIMENSIONS ARE SHOWN FOR PLANNING PURPOSES ONLY.  
For complete information, see Installation Instructions packed with product.

# Drop-In Electric Ranges

## SPECIFICATIONS AND DIMENSIONS

| WHIRLPOOL®                                       |           |                   |
|--|-----------|-------------------|
| MODEL  | WDE150LV  | WDE350LV          |
| Capacity (cu.ft.)                                | 4.5       | 4.5               |
| Recommended MHC                                  | WMH2175XV | WMH75520A         |
| Metal handle*                                    | -         | -                 |
| Designed, engineered and assembled in the U.S.A. | -         | -                 |
| <b>OVEN FEATURES</b>                             |           |                   |
| AccuBake® temperature management system          | -         | -                 |
| Self-cleaning system with Delay Clean            | -         | -                 |
| Delay Bake                                       | -         | -                 |
| Oven Hold Warm                                   | -         | -                 |
| Sabbath Mode                                     | -         | -                 |
| Control lock                                     | -         | -                 |
| Timer display color                              | Blue      | Blue              |
| Oven light                                       | -         | -                 |
| Adjustable racks                                 | 2         | 2                 |
| Large oven window                                | -         | -                 |
| Frameless door design                            | -         | -                 |
| <b>COOKTOP FEATURES</b>                          |           |                   |
| Eco-friendly ceramic glass cooktop**             |           | ♦                 |
| Element type                                     | Coil      | <b>Radiant</b>    |
| Left rear element                                | 8"        | <b>9"/6" dual</b> |
| Right rear element                               | 6"        | 6"                |
| Left front element                               | 6"        | 6"                |
| Right front element                              | 8"        | <b>9"/6" dual</b> |
| <b>DIMENSIONS AND COLORS</b>                     |           |                   |
| Cutout width (A)                                 | 30"       | 30"               |
| Cutout depth (B)                                 | 23¼"      | 23¼"              |
| Countertop height (C)                            | 27½"      | 27½"              |
| Height (D)                                       | 28½"      | 28½"              |
| Base width (E)                                   | 29½"      | 29½"              |
| Recessed depth (F)                               | 26¼"      | 26¼"              |
| Available colors                                 | Q   B   S | Q   B   S         |

Bold type indicates a step-up feature

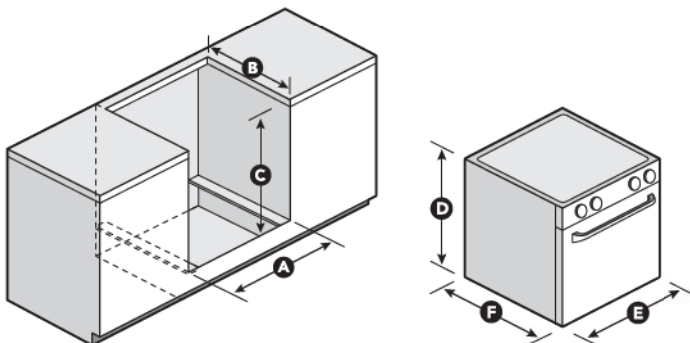

\*Available on Stainless Steel models only. \*\*Glass cooktop surface manufactured without the release of hazardous metals into the earth.

DIMENSIONS ARE SHOWN FOR PLANNING PURPOSES ONLY.  
For complete information, see Installation Instructions packed with product.



# Single Wall Ovens

## SPECIFICATIONS AND DIMENSIONS

| MODEL  | WHIRLPOOL®             |                              | WHIRLPOOL GOLD®        |
|--|------------------------|------------------------------|------------------------|
|  | RBS245PR               | WOS51EC0A                    | WOS92EC0A              |
| Size   | 24"                    | 30"                          | 30"                    |
| Also available in 27"                            |                        | WOS51EC7A                    | WOS92EC7A              |
| Capacity (cu. ft.)                               | 3.1                    | <b>5.0 / 4.3</b>             | 5.0 / 4.3              |
| Recommended cooktops                             | W5CE3024X<br>W5CG3024X | W5CE3024X<br>W5CG3024X       | G9CE3065X<br>G7CG3064X |
| Metal handle                                     |                        | ♦                            | -                      |
| Designed, engineered and assembled in the U.S.A. | -                      | -                            | -                      |
| <b>OVEN FEATURES</b>                             |                        |                              |                        |
| AccuBake® temperature management system          | -                      | -                            | -                      |
| Precise Clean™ self-cleaning system              |                        | ♦                            | -                      |
| Self-cleaning system                             | -                      |                              | -                      |
| SteamClean option                                |                        | ♦                            | -                      |
| Hidden bake element                              |                        | ♦                            | -                      |
| TimeSavor™ Ultra true convection                 |                        |                              | ♦                      |
| Convection Conversion                            |                        |                              | ♦                      |
| Rapid Preheat                                    |                        |                              | ♦                      |
| Preheat countdown                                | Timer                  | Temperature                  | Temperature            |
| Delay Bake                                       | -                      | -                            | -                      |
| Hold Warm  |                        | ♦                            | -                      |
| Custom Broil                                     |                        | ♦                            | -                      |
| Closed door broiling                             | -                      | -                            | -                      |
| Sabbath Mode                                     |                        | ♦                            | -                      |
| Control lock                                     | -                      | -                            | -                      |
| Illuminated display (two-color)                  | -                      | -                            | -                      |
| Oven light                                       | Incandescent           | Incandescent                 | Incandescent           |
| Total adjustable racks                           | 2                      | 2                            | <b>3</b>               |
| Oven window                                      | Large                  | <b>EasyView™ extra-large</b> | EasyView™ extra-large  |
| FIT system                                       |                        | ♦                            | -                      |
| Approved for under-the-counter installation      | -                      | -                            | -                      |
| <b>GENERAL INFORMATION</b>                       |                        |                              |                        |
| Bake element watts at 240/208 volts              | 2000W/1500W            | 2800W/2427W                  | 2800W/2427W            |
| Broil element watts at 240/208 volts             | 3000W/2250W            | 3600W/3120W                  | 3600W/3120W            |
| Convection element watts at 240/208 volts        |                        |                              | 2500W/2167W            |
| Circuit amperage                                 | 30 Amps                | 30 Amps                      | 30 Amps                |
| Total connected load at 240 volts                | 5 kW                   | 3.7 kW                       | 3.7 kW                 |
| Total connected load at 208 volts                | 3.8 kW                 | 2.8 kW                       | 2.8 kW                 |
| 24" Oven cavity size (H x W x D)                 | 16" x 19" x 17 1/8"    |                              |                        |
| 27" Oven cavity size (H x W x D)                 |                        | 18" x 22" x 19"              | 18" x 22" x 19"        |
| 30" Oven cavity size (H x W x D)                 |                        | 18" x 25" x 19"              | 18" x 25" x 19"        |
| <b>DIMENSIONS AND COLORS</b>                     |                        |                              |                        |
| Cutout height (A)                                | 27 1/4"                | 26 1/8"–29 1/8"              | 26 1/8"–29 1/8"        |
| Cutout width (B)                                 | 22 1/2"                | 28 1/2" / 25 1/2"            | 28 1/2" / 25 1/2"      |
| Cutout depth (C)                                 | 23 1/4"                | 24"                          | 24"                    |
| Overall height (D)                               | 29"                    | 28 1/4"                      | 28 1/4"                |
| Overall width (E)                                | 23 1/4"                | 30" / 27"                    | 30" / 27"              |
| Overall depth (F)                                | 26"                    | 26 3/8"                      | 26 3/8"                |
| Available colors (24" and 30" models)            | Q   B   S              | W   B   T   S                | B   S   H   E          |
| Available colors (27" models)                    |                        | W   B   S                    | W   B   S              |

Bold type indicates a step-up feature

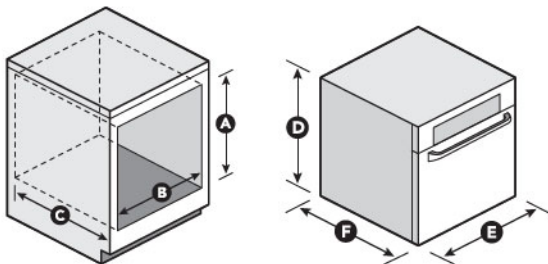

DIMENSIONS ARE SHOWN FOR PLANNING PURPOSES ONLY.  
For complete information, see Installation Instructions packed with product.

# Double Wall Ovens

## SPECIFICATIONS AND DIMENSIONS

|  | WHIRLPOOL®             |  | WHIRLPOOL GOLD®                    |
|--|------------------------|--|------------------------------------|
| MODEL  | RBD245PR               | WOD51EC0A  | WOD93EC0A                          |
| Size   | 24"                    | 30"  | 30"                                |
| Also available in 27"                            |                        | WOD51EC7A  | WOD93EC7A                          |
| Oven capacity (cu. ft.)                          | 3.1 Upper<br>3.1 Lower | <b>5.0 / 4.3 Upper</b><br><b>5.0 / 4.3 Lower</b> | 5.0 / 4.3 Upper<br>5.0 / 4.3 Lower |
| Total capacity (cu. ft.)                         | 6.2                    | <b>10.0 / 8.6</b>                                | 10.0 / 8.6                         |
| Recommended cooktops                             | W5CE3024X<br>W5CG3024X | W5CE3024X<br>W5CG3024X                           | G9CE3074X<br>G7CG3064X             |
| Metal handles                                    |                        | ♦  | -                                  |
| Designed, engineered and assembled in the U.S.A. | -                      | -  | -                                  |
| <b>OVEN FEATURES</b>                             |                        |  |                                    |
| AccuBake® temperature management system          | -                      | -  | -                                  |
| Precise Clean™ self-cleaning system              |                        | ♦  | -                                  |
| Self-cleaning system                             | Upper only             |  |                                    |
| SteamClean option                                |                        | ♦  | -                                  |
| Hidden bake element                              |                        | ♦  | -                                  |
| TimeSavor™ Ultra true convection                 |                        |  | <b>Upper only</b>                  |
| Convection Conversion                            |                        |  | <b>Upper only</b>                  |
| Rapid Preheat                                    |                        |  | ♦                                  |
| Preheat countdown                                | Timer                  | <b>Temperature</b>                               | Temperature                        |
| Delay Bake                                       | -                      | -  | -                                  |
| Hold Warm  |                        | ♦  | -                                  |
| Custom Broil                                     |                        | ♦  | -                                  |
| Closed door broiling                             | -                      | -  | -                                  |
| Sabbath Mode                                     |                        | ♦  | -                                  |
| Control lock                                     | -                      | -  | -                                  |
| Illuminated display (two-color)                  | -                      | -  | -                                  |
| Oven lights                                      | Incandescent           | Incandescent                                     | Incandescent                       |
| Total adjustable racks                           | 2 Upper / 2 Lower      | 2 Upper / 2 Lower                                | <b>3 Upper / 2 Lower</b>           |
| Oven window                                      | Large                  | <b>EasyView™ extra-large</b>                     | EasyView™ extra-large              |
| FIT system                                       |                        | ♦  | -                                  |
| <b>GENERAL INFORMATION</b>                       |                        |  |                                    |
| Bake element watts at 240/208 volts              | 2000W/1500W            | 2800W/2427W                                      | 2800W/2427W                        |
| Broil element watts at 240/208 volts             | 3000W/2250W            | 3600W/3120W                                      | 3600W/3120W                        |
| Convection element watts at 240/208 volts        |                        |  | 2500W/2167W                        |
| Circuit amperage                                 | 40 Amps                | 40 Amps  | 40 Amps                            |
| Total connected load at 240 volts                | 8 kW                   | 7.4 kW   | 7.4 kW                             |
| Total connected load at 208 volts                | 6 kW                   | 5.6 kW   | 5.6 kW                             |
| 24" Oven cavity size (H x W x D)                 | 16" x 19" x 17½"       |  |                                    |
| 27" Oven cavity size (H x W x D)                 |                        | 18" x 22" x 19"                                  | 18" x 22" x 19"                    |
| 30" Oven cavity size (H x W x D)                 |                        | 18" x 25" x 19"                                  | 18" x 25" x 19"                    |
| <b>DIMENSIONS AND COLORS</b>                     |                        |  |                                    |
| Cutout height (A)                                | 49¾"                   | 48⅞"-52⅞"  | 48⅞"-52⅞"                          |
| Cutout width (B)                                 | 22½"                   | 28½" / 25½"                                      | 28½" / 25½"                        |
| Cutout depth (C)                                 | 23¼"                   | 24"  | 24"                                |
| Overall height (D)                               | 51"                    | 51⅞"   | 51⅞"                               |
| Overall width (E)                                | 23¼"                   | 30" / 27"  | 30" / 27"                          |
| Overall depth (F)                                | 26"                    | 26⅞"   | 26⅞"                               |
| Available colors (24" and 30" models)            | Q   B   S              | W   B   S  | B   S   H   E                      |
| Available colors (27" models)                    |                        | W   B   S  | W   B   S                          |

Bold type indicates a step-up feature

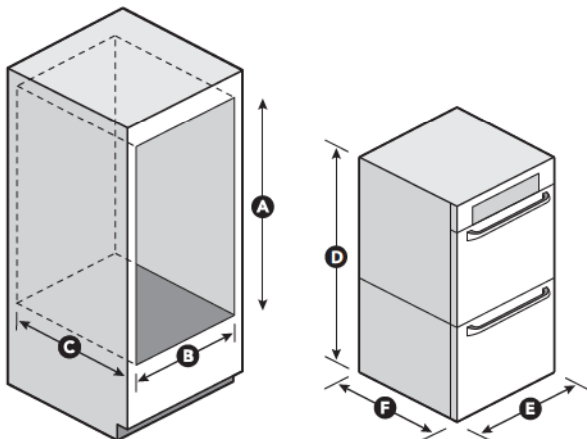

DIMENSIONS ARE SHOWN FOR PLANNING PURPOSES ONLY.  
For complete information, see Installation Instructions packed with product.

# Combination Microwave Wall Ovens

## SPECIFICATIONS AND DIMENSIONS

| MODEL  | WHIRLPOOL®             | WHIRLPOOL GOLD®        |
|--|------------------------|------------------------|
|  | WOC54EC0A              | WOC95EC0A              |
| Size   | 30"                    | 30"                    |
| Also available in 27"                            | WOC54EC7A              |                        |
| Upper microwave oven capacity (cu. ft.)          | 1.4                    | 1.4                    |
| Lower oven capacity (cu. ft.)                    | 5.0 / 4.3              | 5.0                    |
| Recommended cooktops                             | W5CE3024X<br>W5CG3024X | G9CE3074X<br>G7CG3064X |
| Metal handles                                    | -                      | -                      |
| Designed, engineered and assembled in the U.S.A. | -                      | -                      |
| <b>UPPER MICROWAVE OVEN FEATURES</b>             |                        |                        |
| Sensor microwave with drop-down door             | -                      | -                      |
| Steam cooking                                    | 8205262RB              | 8205262RB              |
| Power (watts)                                    | 900                    | 900                    |
| Stainless steel interior                         | -                      | -                      |
| Turntable diameter                               | 14 1/8"                | 14 1/8"                |
| <b>OVEN FEATURES</b>                             |                        |                        |
| AccuBake® temperature management system          | -                      | -                      |
| Precise Clean™ self-cleaning system              | -                      | -                      |
| SteamClean option                                | -                      | -                      |
| Hidden bake element                              | -                      | -                      |
| TimeSavor™ Ultra true convection                 | -                      | ♦                      |
| Convection Conversion                            | -                      | ♦                      |
| Rapid Preheat                                    | -                      | ♦                      |
| Preheat countdown                                | Temperature            | Temperature            |
| Delay Bake                                       | -                      | -                      |
| Hold Warm  | -                      | -                      |
| Custom Broil                                     | -                      | -                      |
| Closed door broiling                             | -                      | -                      |
| Sabbath Mode                                     | -                      | -                      |
| Control lock                                     | -                      | -                      |
| Illuminated display (two-color)                  | -                      | -                      |
| Oven lights                                      | Incandescent           | Incandescent           |
| Total adjustable racks                           | 2                      | 3                      |
| EasyView™ extra-large oven window                | -                      | -                      |
| <b>GENERAL INFORMATION</b>                       |                        |                        |
| Bake element watts at 240/208 volts              | 2800W/2427W            | 2800W/2427W            |
| Broil element watts at 240/208 volts             | 3600W/3120W            | 3600W/3120W            |
| Convection element watts at 240/208 volts        |                        | 2500W/2167W            |
| Circuit amperage                                 | 40 Amps                | 40 Amps                |
| Total connected load at 240 volts                | 5.5 kW                 | 5.5 kW                 |
| Total connected load at 208 volts                | 4.6 kW                 | 4.6 kW                 |
| 27" Oven cavity size (H x W x D)                 | 18" x 22" x 19"        |                        |
| 30" Oven cavity size (H x W x D)                 | 18" x 25" x 19"        | 18" x 25" x 19"        |
| <b>DIMENSIONS AND COLORS</b>                     |                        |                        |
| Cutout height (A)                                | 41"-41 1/2"            | 41"-41 1/2"            |
| Cutout width (B)                                 | 28 1/2" / 25 1/2"      | 28 1/2"                |
| Cutout depth (C)                                 | 24"                    | 24"                    |
| Overall height (D)                               | 42 3/8"                | 42 3/8"                |
| Overall width (E)                                | 30" / 27"              | 30"                    |
| Overall depth (F)                                | 26 3/8"                | 26 3/8"                |
| Available colors                                 | W   B   S              | B   S   H   E          |

Bold type indicates a step-up feature

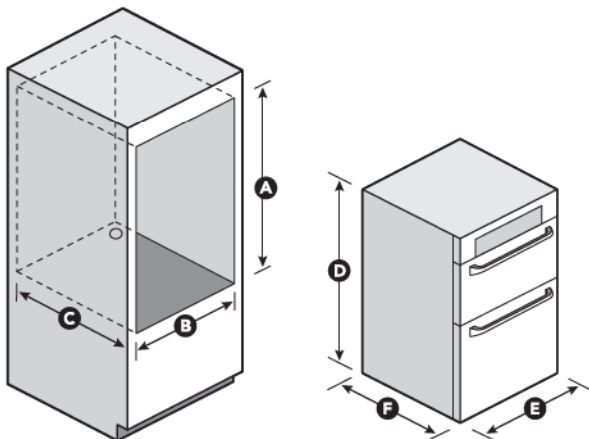

DIMENSIONS ARE SHOWN FOR PLANNING PURPOSES ONLY.  
For complete information, see Installation Instructions packed with product.

# Electric Cooktops

## SPECIFICATIONS AND DIMENSIONS

| MODEL  | WHIRLPOOL®                                |   |   | WHIRLPOOL GOLD®                                     |   |
|--|---|---|---|---|---|
|  | RCS2012R                                  | WCC31430A                                 | W5CE3024X                                 | G7CE3034X   | G7CE3055X                                   |
|  | 21" Coil                                  | 30" Coil                                  | 30" Ceramic glass                         | 30" Ceramic glass                                   | 30" Ceramic glass                           |
| Recommended wall oven                            | WOS51EC0/7A<br>WOD51EC0/7A<br>WOC54EC0/7A | WOS51EC0/7A<br>WOD51EC0/7A<br>WOC54EC0/7A | WOS51EC0/7A<br>WOD51EC0/7A<br>WOC54EC0/7A | WOS92EC0/7A<br>WOD93EC0/7A<br>WOC95EC0A             | WOS92EC0/7A<br>WOD93EC0/7A<br>WOC95EC0A     |
| Volts/Circuit Amps or VAC required               | 240/20                                    | 240/40                                    | 240/30                                    | 240/40  | 240/40                                      |
| Designed, engineered and assembled in the U.S.A. | -   | -   | -   | -   | -   |
| <b>PERFORMANCE FEATURES</b>                      |   |   |   |   |   |
| Element type                                     | High-speed coil                           | High-speed coil                           | <b>Radiant</b>                            | Radiant   | Radiant                                     |
| Left rear element                                |   | 8" 2,350-watt                             | 7" 1,800-watt                             | <b>10" 2,500-watt</b>                               | 6" 1,200-watt                               |
| Right rear element                               |   | 6" 1,500-watt                             | 6" 1,200-watt                             | 6" 1,200-watt                                       | <b>6" 100-watt Warm Zone</b>                |
| Left front element                               | 6" 1,250/900-watt                         | 6" 1,500-watt                             | 6" 1,200-watt                             | 6" 1,200-watt                                       | <b>10" 2,500-watt</b>                       |
| Right front element                              | 8" 2,100/1,575-watt                       | 8" 2,350-watt                             | <b>9" 2,500-watt</b>                      | <b>12"/9" 3,000/1,900-watt<br/>AccuSimmer® dual</b> | 10"/6" 2,500/1,200-watt<br>AccuSimmer® dual |
| Center rear element                              |   |   |   |   | <b>6" 1,200-watt</b>                        |
| Simmer function                                  |   |   | ♦   | -   | -   |
| Chrome drip bowls                                | -   | <b>No Drip</b>                            |   |   |   |
| <b>CONVENIENCE FEATURES</b>                      |   |   |   |   |   |
| Controls   | Knobs                                     | Knobs                                     | Knobs                                     | <b>Stainless steel finish knobs*</b>                | Stainless steel finish knobs*               |
| Dishwasher-safe control knobs                    |   | ♦   | -   | -   | -   |
| Cooktop surface                                  | Stainless steel                           | <b>Porcelain SpillGuard™</b>              | <b>Eco-friendly ceramic glass**</b>       | Eco-friendly ceramic glass**                        | Eco-friendly ceramic glass**                |
| Infinite heat controls                           | -   | -   | ♦   | -   | -   |
| Hot surface indicator lights                     |   |   | ♦   | -   | -   |
| Power "On" light                                 | -   | -   | -   | -   | -   |
| Compatible above wall oven                       |   | ♦   | -   | -   | -   |
| <b>DIMENSIONS AND COLORS</b>                     |   |   |   |   |   |
| Cutout width (A)                                 | 18 1/4"                                   | 28 3/4"                                   | 29 1/2"                                   | 29 1/2"   | 29 1/2"                                     |
| Cutout depth (B)                                 | 15 1/2"                                   | 19 3/8"                                   | 20 1/2"                                   | 20 1/2"   | 20 1/2"                                     |
| Height (C)                                       | 2 1/8"                                    | 3 1/4"                                    | 3 1/4"                                    | 3 1/4"  | 3 1/4"                                      |
| Width (D)  | 21"                                       | 30"                                       | 30 3/8"                                   | 30 3/8"   | 30 3/8"                                     |
| Depth (E)  | 16 1/2"                                   | 21"                                       | 21 1/4"                                   | 21 1/4"   | 21 1/4"                                     |
| Available colors                                 | S   | W   B   R                                 | W   B   S                                 | P   B   C   S                                       | B   S                                       |

Bold type indicates a step-up feature

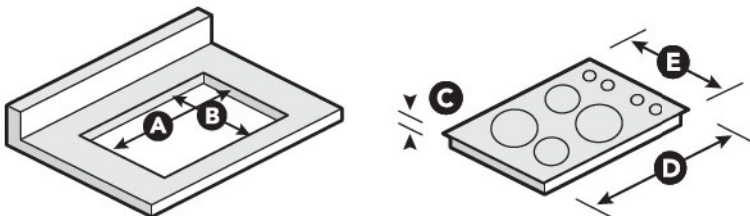

\*Stainless Steel models only. \*\*Glass cooktop surface manufactured without the release of hazardous metals into the earth.

DIMENSIONS ARE SHOWN FOR PLANNING PURPOSES ONLY.  
For complete information, see Installation Instructions packed with product.

# Electric Cooktops

## SPECIFICATIONS AND DIMENSIONS

| MODEL  | WHIRLPOOL GOLD*                         |  |   | WHIRLPOOL*                              | WHIRLPOOL GOLD*                             |  |
|--|---|--|---|---|---|--|
|  | G9CE3065X                               | G9CE3074X                                      | GCI3061X                                | W5CE3625A                               | G7CE3635X                                   | G9CE3675X                                      |
|  | 30" Ceramic glass                       | 30" Ceramic glass                              | 30" Induction                           | 36" Ceramic glass                       | 36" Ceramic glass                           | 36" Ceramic glass                              |
| Recommended wall oven                            | WOS92EC0/7A<br>WOD93EC0/7A<br>WOC95EC0A | WOS92EC0/7A<br>WOD93EC0/7A<br>WOC95EC0A        | WOS92EC0/7A<br>WOD93EC0/7A<br>WOC95EC0A | WOS92EC0/7A<br>WOD93EC0/7A<br>WOC95EC0A | WOS92EC0/7A<br>WOD93EC0/7A<br>WOC95EC0A     | WOS92EC0/7A<br>WOD93EC0/7A<br>WOC95EC0A        |
| ADA compliant†                                   | ♦                                       | -  | -                                       | -                                       | -   | ♦  |
| Volts/Circuit Amps or VAC required               | 240/30                                  | 240/40   | 240/40                                  | 240/40                                  | 240/40                                      | 240/40   |
| Designed, engineered and assembled in the U.S.A. | -                                       | -  | -                                       | ♦                                       | -   | -  |
| <b>PERFORMANCE FEATURES</b>                      |   |  |   |   |   |  |
| AccuHeat™ induction technology                   | ♦                                       |  |   |   |   |  |
| Element type                                     | AccuSimmer® Plus radiant                | AccuSimmer® Plus radiant                       | Induction                               | Radiant                                 | Radiant                                     | AccuSimmer® Plus radiant                       |
| Left rear element                                | 9" 2,200-watt                           | 10"/6"<br>2,500/1,200-watt dual                | 9" 2,300/3,200-watt Boost               | 10" 2,500-watt                          | 10"/6"<br>2,500/1,200-watt dual             | 10"/6"<br>2,500/1,200-watt dual                |
| Right rear element                               | 10"/6"<br>2,500/1,200-watt dual         | 12"/9"/6"<br>3,000/1,950/<br>1,050-watt triple | 8" 2,300-watt                           | 10"/6"<br>2,500/1,200-watt dual         | 12"/9"<br>3,000/1,900-watt AccuSimmer® dual | 12"/9"/6"<br>3,000/1,950/<br>1,050-watt triple |
| Left front element                               | 6" 1,200-watt                           | 6" 1,200-watt                                  | 6" 1,400-watt                           | 6" 1,200-watt                           | 6" 1,200-watt                               | 6" 1,200-watt                                  |
| Right front element                              | 6" 1,200-watt                           | 6" 1,200-watt                                  | 6" 1,400-watt                           | 6" 1,200-watt                           | 6" 1,200-watt                               | 6" 1,200-watt                                  |
| Center rear element                              | 6" 100-watt Warm Zone                   |  |   | 6" 100-watt Warm Zone                   | 6" 100-watt Warm Zone                       | 6" 1,200-watt                                  |
| Boost function                                   |   |  | ♦                                       |   |   |  |
| Simmer function                                  | -                                       | -  | -                                       | -                                       | -   | -  |
| <b>CONVENIENCE FEATURES</b>                      |   |  |   |   |   |  |
| Controls   | Tap Touch                               | Tap Touch                                      | Tap Touch                               | Knobs                                   | Stainless steel finish knobs*               | Tap Touch                                      |
| Dishwasher-safe control knobs                    |   |  |   | -                                       | -   |  |
| Ceramic glass cooktop                            | Eco-friendly**                          | Eco-friendly**                                 | -                                       | Eco-friendly**                          | Eco-friendly**                              | Eco-friendly**                                 |
| Infinite heat controls                           |   |  |   | -                                       | -   |  |
| Hot surface indicator lights                     | -                                       | -  | -                                       | -                                       | -   | -  |
| Power "On" light                                 | -                                       | -  | -                                       | -                                       | -   | -  |
| Automatic pan detection                          |   |  | ♦                                       |   |   |  |
| Timer  |   |  | ♦                                       |   |   |  |
| Control lock                                     | ♦                                       | -  | -                                       |   |   | ♦  |
| Compatible above wall oven                       | -                                       | -  | -                                       | -                                       | ♦   | -  |
| <b>DIMENSIONS AND COLORS</b>                     |   |  |   |   |   |  |
| Cutout width (A)                                 | 29½"                                    | 29½"   | 29½"                                    | 35½"                                    | 35½"  | 35½"   |
| Cutout depth (B)                                 | 20½"                                    | 20½"   | 19½"                                    | 20½"                                    | 20½"  | 20½"   |
| Height (C)                                       | 3¼"                                     | 3¼"  | 2¾"                                     | 3¼"                                     | 3¼"   | 3¼"  |
| Width (D)  | 30¾"                                    | 30¾"   | 30¾"                                    | 36¾"                                    | 36¾"  | 36¾"   |
| Depth (E)  | 21¼"                                    | 21¼"   | 21¼"                                    | 21¼"                                    | 21¼"  | 21¼"   |
| Available colors                                 | B   S                                   | B  | B                                       | B                                       | B   S                                       | B   S  |

Bold type indicates a step-up feature

\*Stainless Steel models only. \*\*Glass cooktop surface manufactured without the release of hazardous metals into the earth.  
†Meets ADA push/pull force and reach guidelines.

DIMENSIONS ARE SHOWN FOR PLANNING PURPOSES ONLY.  
For complete information, see Installation Instructions packed with product.



# Gas Cooktops

## SPECIFICATIONS AND DIMENSIONS

| MODEL  | WHIRLPOOL®                                |   | WHIRLPOOL GOLD®                         |   | WHIRLPOOL®                                |   | WHIRLPOOL GOLD®                         |   |
|--|---|---|---|---|---|---|---|---|
|  | W3CG3014X                                 | W5CG3024X                                 | GLT3057R                                | G7CG3064X                               | W5CG3625X                                 | GLT3657R                                | G7CG3665X                               | GLS3665R                                |
|  | 30" Porcelain or stainless steel          | 30" Porcelain or stainless steel          | 30" Tempered glass                      | 30" Stainless steel                     | 36" Porcelain or stainless steel          | 36" Tempered glass                      | 36" Stainless steel                     | 36" Stainless steel                     |
| Recommended wall oven                            | WOS51EC0/7A<br>WOD51EC0/7A<br>WOC54EC0/7A | WOS51EC0/7A<br>WOD51EC0/7A<br>WOC54EC0/7A | WOS92EC0/7A<br>WOD93EC0/7A<br>WOC95EC0A | WOS92EC0/7A<br>WOD93EC0/7A<br>WOC95EC0A | WOS51EC0/7A<br>WOD51EC0/7A<br>WOC54EC0/7A | WOS92EC0/7A<br>WOD93EC0/7A<br>WOC95EC0A | WOS92EC0/7A<br>WOD93EC0/7A<br>WOC95EC0A | WOS92EC0/7A<br>WOD93EC0/7A<br>WOC95EC0A |
| ADA compliant*                                   | -   | -   | -                                       | ♦                                       | -   | -                                       | ♦                                       | -                                       |
| Volts/Amps required                              | 120/15                                    | 120/15                                    | 120/15                                  | 120/15                                  | 120/15                                    | 120/15                                  | 120/15                                  | 120/15                                  |
| Designed, engineered and assembled in the U.S.A. | -   | -   | -                                       | -                                       | -   | -                                       | -                                       | -                                       |
| <b>PERFORMANCE FEATURES</b>                      |   |   |   |   |   |   |   |   |
| Left rear burner                                 | 9,100 BTU                                 | <b>12,500 BTU Power™</b>                  | 9,100 BTU                               | <b>9,200 BTU</b>                        | 9,200 BTU                                 | <b>6,000 BTU AccuSimmer®</b>            | 5,000 BTU AccuSimmer®                   | 9,000 BTU                               |
| Right rear burner                                | 9,100 BTU                                 | <b>9,200 BTU</b>                          | <b>6,000 BTU AccuSimmer®</b>            | <b>15,000 BTU Power™</b>                | 9,200 BTU                                 | <b>6,000 BTU AccuSimmer®</b>            | <b>12,500 BTU Power™</b>                | 12,000 BTU Power™                       |
| Left front burner                                | 10,500 BTU                                | <b>5,000 BTU AccuSimmer®</b>              | <b>12,500 BTU Power™</b>                | <b>17,000 BTU Power™</b>                | 9,200 BTU                                 | <b>12,500 BTU Power™</b>                | <b>17,000 BTU Flex Power™</b>           | 12,000 BTU Power™                       |
| Right front burner                               | 5,000 BTU AccuSimmer®                     | <b>12,500 BTU Power™</b>                  | 12,500 BTU Power™                       | 5,000 BTU AccuSimmer®                   | <b>12,500 BTU Power™</b>                  | 12,500 BTU Power™                       | 5,000 BTU AccuSimmer®                   | 9,000 BTU                               |
| Center rear burner                               |   |   |   |   | <b>5,000 BTU AccuSimmer®</b>              | 9,100 BTU                               | <b>9,000 BTU Oval</b>                   |   |
| Center burner                                    |   |   |   |   |   |   |   | <b>15,000 BTU Power™</b>                |
| <b>CONVENIENCE FEATURES</b>                      |   |   |   |   |   |   |   |   |
| Control knobs                                    | -   | <b>Dishwasher safe</b>                    | Dishwasher safe                         | Dishwasher safe                         | Dishwasher safe                           | Dishwasher safe                         | Dishwasher safe                         | -                                       |
| Stainless steel finish control knobs             |   |   |   | ♦                                       |   |   | ♦                                       | -                                       |
| Recessed grate design                            |   |   |   |   |   |   |   | ♦                                       |
| Dishwasher-safe grates                           | Enamel steel                              | <b>Full-width, cast-iron</b>              | Full-width, cast-iron                   | Full-width, cast-iron                   | Full-width, cast-iron                     | Full-width, cast-iron                   | Full-width, cast-iron                   | Full-width, cast-iron                   |
| Sealed burners                                   | -   | -   | -                                       | -                                       | -   | -                                       | -                                       | -                                       |
| Infinite heat controls                           | -   | -   | -                                       | -                                       | -   | -                                       | -                                       | -                                       |
| Included LP conversion kit                       | -   | -   | -                                       | -                                       | -   | -                                       | -                                       | -                                       |
| Compatible above wall oven                       | -   | -   | -                                       | -                                       | -   | -                                       | -                                       | -                                       |
| <b>DIMENSIONS AND COLORS</b>                     |   |   |   |   |   |   |   |   |
| Cutout width (A)                                 | 29"                                       | 29"                                       | 29"                                     | 29"                                     | 35 1/4"                                   | 35 1/4"                                 | 35 1/4"                                 | 35 1/4"                                 |
| Cutout depth (B)                                 | 19"                                       | 19"                                       | 19"                                     | 19"                                     | 19"                                       | 19"                                     | 19"                                     | 19 1/2"                                 |
| Height (C)                                       | 2 1/8"                                    | 3 2/32"                                   | 2 1/8"                                  | 3 1/2"                                  | 3 3/8"                                    | 2 1/8"                                  | 3 1/2"                                  | 2 21/32"                                |
| Width (D)  | 31 1/16"                                  | 29 1/2"                                   | 30 3/16"                                | 31 1/8"                                 | 36"                                       | 36 3/16"                                | 37 3/32"                                | 36"                                     |
| Depth (E)  | 21 1/4"                                   | 21 1/2"                                   | 21 1/4"                                 | 21"                                     | 21"                                       | 21 1/4"                                 | 20 5/16"                                | 20 1/4"                                 |
| Available colors                                 | W   B   S                                 | W   B   S                                 | B                                       | S                                       | B   S                                     | B                                       | S                                       | S                                       |

Bold type indicates a step-up feature

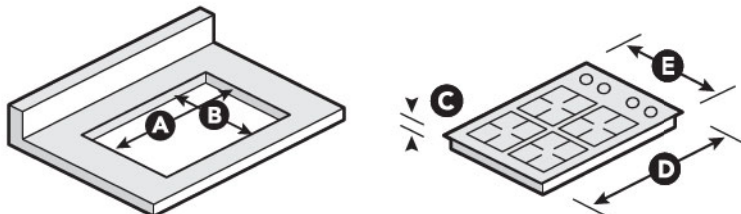

\*Meets ADA push/pull force and reach range guidelines.

DIMENSIONS ARE SHOWN FOR PLANNING PURPOSES ONLY.  
For complete information, see Installation Instructions packed with product.

# Modular Cooktop

## SPECIFICATIONS AND DIMENSIONS

| MODEL   |  | WHIRLPOOL®<br>SC8720ED                    |
|---|--|---|
| 30" Modular Downdraft Gas Cooktop                           |  |   |
| Recommended wall oven                                       |  | WOS51EC0/7A<br>WOD51EC0/7A<br>WOC54EC0/7A |
| Designed, engineered and assembled in the U.S.A.            |  |   |
| FEATURES  |  |   |
| Downdraft vent  |  | -   |
| 10,000-BTU fixed burners                                    |  | 2   |
| Optional modules available                                  |  | 3"  |
| Infinite heat controls                                      |  | -   |
| Dishwasher-safe control knobs                               |  | Lift off                                  |
| Dishwasher-safe, full-width, cast-iron, matte-finish grates |  | -   |
| Sealed burners  |  | -   |
| Removable/washable vent filter                              |  | -   |
| Included LP conversion kit                                  |  | -   |
| DIMENSIONS AND COLORS                                       |  |   |
| Cutout width (A)  |  | 28 7/8"                                   |
| Cutout depth (B)  |  | 20 9/16"                                  |
| Height (C)  |  | 4"-16"                                    |
| Width (D)   |  | 29 1/8"                                   |
| Depth (E)   |  | 21 1/2"                                   |
| Available colors  |  | B   |

| MODEL   |            | WHIRLPOOL® |            |        |
|---|------------|------------|------------|--------|
|   | SCM10D     | SCM20D     | SCM40D     |        |
|   | 30" Module | 30" Module | 30" Module |        |
| FEATURES  |            |            |            |        |
| Surface burner module                           | -          | -          | -          | -      |
| Non-stick grill module                          | -          | -          | -          | -      |
| Grill cover                                     | -          | SCM50D     | -          | -      |
| Non-stick griddle module                        | -          | -          | -          | -      |
| Grill module element required as a power source | -          | -          | -          | SCM20D |
| DIMENSIONS AND COLORS                           |            |            |            |        |
| Available colors                                | B          | B          | B          | B      |

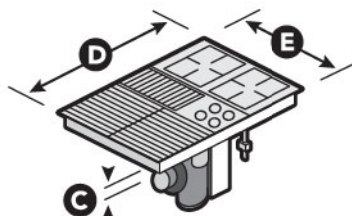
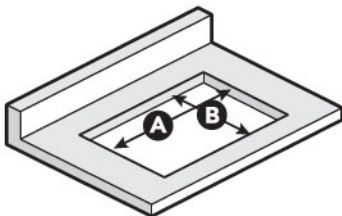

\*\*Cooktop is shipped with one open bay and two fixed burners in the right bay. Select from the module options to complete your cooktop. Nonstick grill, surface burner and non-stick griddle modules available.

DIMENSIONS ARE SHOWN FOR PLANNING PURPOSES ONLY. For complete information, see Installation Instructions packed with product.

# Microwave Hood Combinations

## SPECIFICATIONS AND DIMENSIONS

| MODEL                              | WHIRLPOOL®           |                      |                      | WHIRLPOOL GOLD®      |                                     |   |
|------------------------------------|----------------------|----------------------|----------------------|----------------------|-------------------------------------|---|
|                                    | WMH31017A            | WMH32517A            | WMH53520A            | WMH75520A            | WMH76718A                           | GH7208XR                                    |
| Capacity (cu. ft.)                 | 1.7                  | 1.7                  | 2.0                  | 2.0                  | 1.8                                 | 2.0   |
| Stainless steel finish handle*     | -                    | -                    | -                    | -                    | -                                   | -   |
| <b>COOKING SYSTEM</b>              |                      |                      |                      |                      |                                     |   |
| Sensor cooking                     | -                    | ♦                    | -                    | -                    | -                                   | -   |
| Power (watts)                      | 1,000                | 1,000                | 1,000                | 1,100                | 1,100                               | 1,200                                       |
| Grill watts                        | -                    | -                    | -                    | -                    | -                                   | 1,500                                       |
| Velos® SpeedCook oven              | -                    | -                    | -                    | -                    | -                                   | ♦   |
| AccuWave® power system             | -                    | -                    | -                    | ♦                    | -                                   | ♦   |
| TimeSaver™ Plus true convection    | -                    | -                    | -                    | -                    | ♦                                   | -   |
| 10 Variable power levels           | -                    | -                    | -                    | -                    | -                                   | -   |
| SpeedCook technology with grilling | -                    | -                    | -                    | -                    | -                                   | ♦   |
| Steam cooking                      | -                    | ♦                    | -                    | -                    | -                                   | -   |
| Staged cooking                     | -                    | -                    | -                    | -                    | -                                   | -   |
| <b>VENTILATION SYSTEM</b>          |                      |                      |                      |                      |                                     |   |
| Auto Adapt fan                     | -                    | -                    | ♦                    | -                    | -                                   | -   |
| Convertible ventilation system     | 2-speed, 220 CFM fan | 3-speed, 300 CFM fan | 4-speed, 400 CFM fan | 4-speed, 300 CFM fan | 4-speed, 300 CFM fan                | 4-speed, TruCapture® 300 CFM fan            |
| Hidden vent                        | -                    | -                    | -                    | -                    | -                                   | -   |
| Filter change indicator            | -                    | -                    | -                    | -                    | -                                   | -   |
| <b>CYCLES</b>                      |                      |                      |                      |                      |                                     |   |
| Broil function                     | -                    | -                    | -                    | -                    | -                                   | ♦   |
| Convection Bake and Roast          | -                    | -                    | -                    | -                    | ♦                                   | -   |
| AccuSimmer® cycle                  | -                    | ♦                    | -                    | -                    | -                                   | -   |
| Auto Cook, Defrost, Reheat         | -                    | -                    | -                    | -                    | -                                   | -   |
| Kids Menu                          | -                    | -                    | -                    | ♦                    | -                                   | -   |
| Melt/Soften                        | -                    | -                    | -                    | -                    | -                                   | -   |
| Warm Hold                          | -                    | ♦                    | -                    | -                    | -                                   | -   |
| <b>CONVENIENCE FEATURES</b>        |                      |                      |                      |                      |                                     |   |
| CleanRelease® non-stick interior   | -                    | -                    | ♦                    | -                    | -                                   | -   |
| Most Used cycle                    | -                    | -                    | -                    | -                    | -                                   | ♦   |
| Touch screen controls              | -                    | -                    | -                    | -                    | -                                   | ♦   |
| Control lock                       | -                    | -                    | -                    | -                    | -                                   | -   |
| Add 30 seconds                     | -                    | -                    | -                    | -                    | -                                   | -   |
| Recessed glass turntable           | -                    | <b>Stoppable</b>     | Stoppable            | Stoppable            | Stoppable                           | Stoppable                                   |
| Cooking rack                       | -                    | ♦                    | -                    | -                    | <b>Cooking and convection racks</b> | Convection rack, grill rack and crisper pan |
| Timer display color                | Blue                 | Blue                 | Blue                 | Blue                 | Blue                                | <b>Touch screen</b>                         |
| EZ-View™ lighting                  | -                    | -                    | -                    | -                    | -                                   | <b>Halogen lighting</b>                     |
| Night-light setting                | -                    | -                    | -                    | -                    | -                                   | -   |
| <b>ACCESSORIES</b>                 |                      |                      |                      |                      |                                     |   |
| Microwave steamer                  | -                    | -                    | -                    | Optional             | ♦                                   | -   |
| Crisper pan with handle            | -                    | -                    | -                    | -                    | -                                   | ♦   |
| Grease filter part number          | W10208631A           | W10208631A           | W10208631A           | W10208631            | W10208631                           | W10120839A                                  |
| Charcoal filter part number        | 8206230A             | 8206230A             | 8206230A             | 8206230A             | 8206230A                            | W10120840A                                  |
| <b>DIMENSIONS AND COLORS</b>       |                      |                      |                      |                      |                                     |   |
| Minimum cutout width (A)           | 30"                  | 30"                  | 30"                  | 30"                  | 30"                                 | 30"   |
| Minimum install height (B)         | 66"                  | 66"                  | 66"                  | 66"                  | 66"                                 | 66"   |
| Height (C)                         | 17¼"                 | 17¼"                 | 17¼"                 | 17¼"                 | 17¼"                                | 15¼"  |
| Width (D)                          | 29⅞"                 | 29⅞"                 | 29⅞"                 | 29⅞"                 | 29⅞"                                | 29⅞"  |
| Depth (E)                          | 16¼"                 | 16¼"                 | 16¼"                 | 16"                  | 16"                                 | 18¼"  |
| Available colors                   | W   B   D   S        | W   B   T   S        | W   B   S   H   E    | W   B   S            | W   B   S                           | S   |

Bold type indicates a step-up feature

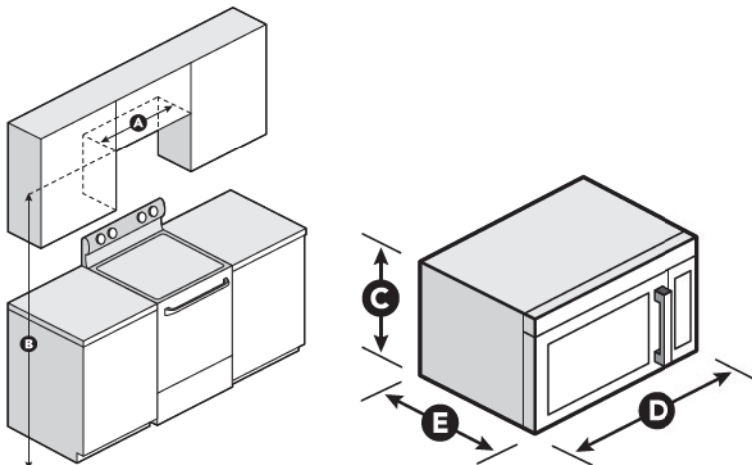

\*Available on Stainless Steel, Monochromatic Stainless Steel, White Ice and Black Ice models only.

DIMENSIONS ARE SHOWN FOR PLANNING PURPOSES ONLY.  
For complete information, see Installation Instructions packed with product.

# Countertop Microwaves

## SPECIFICATIONS AND DIMENSIONS

| MODEL   | WHIRLPOOL® |                    |             |                   |                  |                             |
|---|------------|--------------------|-------------|-------------------|------------------|-----------------------------|
|   | WMC10007A  | WMC10511A          | WMC11511A   | WMC30516A         | WMC20005Y        | WMC50522A                   |
| <b>New 2013 model</b>                         |            |                    |             |                   |                  |                             |
| Capacity (cu. ft.)                            | 0.7        | 1.1                | 1.1         | 1.6               | 0.5              | 2.2                         |
| <b>COOKING SYSTEM</b>                         |            |                    |             |                   |                  |                             |
| Sensor cooking                                |            | ♦                  | -           | -                 |                  | ♦                           |
| Power (watts)                                 | 700        | <b>1,000</b>       | 1,000       | <b>1,200</b>      | 750              | <b>1,200</b>                |
| 10 Variable power levels                      | -          | -                  | -           | -                 | -                | -                           |
| Staged cooking                                |            | ♦                  | -           | -                 |                  |                             |
| <b>PROGRAMMED CYCLES AND SENSOR FUNCTIONS</b> |            |                    |             |                   |                  |                             |
| Soups/Sauces                                  |            |                    |             | <b>Programmed</b> |                  | <b>Programmed</b>           |
| Dinner Plate                                  | Programmed | <b>Sensor</b>      | Sensor      | Sensor            |                  | <b>Sensor</b>               |
| Pizza Reheat                                  | Programmed | Programmed         | Programmed  | Programmed        |                  | <b>Programmed</b>           |
| Beverage                                      | Programmed | Programmed         | Programmed  | Programmed        |                  | <b>Programmed</b>           |
| Frozen Entree                                 | Programmed | <b>Sensor</b>      | Sensor      | Programmed        |                  | <b>Programmed</b>           |
| Popcorn                                       | Programmed | Programmed         | Programmed  | Programmed        | Programmed       | Programmed                  |
| Fresh Vegetables                              | Programmed |                    |             |                   |                  | <b>Sensor</b>               |
| Baked Potato                                  | Programmed | Programmed         | Programmed  | Programmed        |                  | <b>Programmed</b>           |
| <b>CYCLES</b>                                 |            |                    |             |                   |                  |                             |
| Manual Cook                                   |            |                    |             |                   | ♦                |                             |
| Auto Defrost                                  | -          | -                  | -           | -                 | -                | -                           |
| Manual Reheat                                 |            |                    |             |                   | ♦                |                             |
| <b>CONVENIENCE FEATURES</b>                   |            |                    |             |                   |                  |                             |
| Electronic touch controls                     | -          | -                  | -           | -                 | <b>Tap Touch</b> | -                           |
| Time cook                                     | -          | -                  | -           | -                 | -                | -                           |
| Add-a-Minute option                           | -          |                    |             |                   |                  | ♦                           |
| Add 30 seconds option                         |            | ♦                  | -           | -                 | -                | -                           |
| Control lock                                  | -          | -                  | -           | -                 | -                | -                           |
| Rounded-back design                           |            |                    |             |                   | ♦                |                             |
| Turntable                                     | -          | <b>Large glass</b> | Large glass | Large glass       | Glass            | <b>Large recessed glass</b> |
| Microwave Built-in trim kit                   |            |                    |             | <b>Optional</b>   |                  | <b>Optional</b>             |
| Under counter mounting bracket                | -          |                    |             |                   |                  |                             |
| <b>DIMENSIONS AND COLORS</b>                  |            |                    |             |                   |                  |                             |
| Height (A)                                    | 13 1/8"    | 12 1/8"            | 12 1/8"     | 13"               | 14 1/8"          | 12 1/8"                     |
| Width (B)                                     | 17 13/16"  | 20 1/4"            | 20 1/4"     | 21 1/4"           | 15 1/8"          | 24"                         |
| Depth (C)                                     | 10 1/8"    | 16 1/4"            | 16 1/8"     | 17 1/4"           | 13 3/4"          | 19 1/4"                     |
| Available colors                              | W   B      | W   B              | S           | W   B   S         | W   B   D        | W   B   S                   |

Bold type indicates a step-up feature

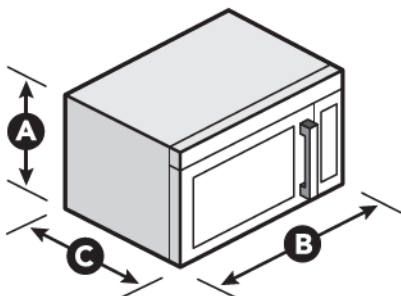

DIMENSIONS ARE SHOWN FOR PLANNING PURPOSES ONLY.  
For complete information, see Installation Instructions packed with product.

# Under Cabinet Hoods

## SPECIFICATIONS AND DIMENSIONS

WHIRLPOOL GOLD®

| MODEL                                 | UXT2030AY                   | UXT3030AY                   | UXT4030AY                   | UXT4230AY                                | UXT5230AY  | UXT5530AA                                 | GXU7130DX                     |
|---------------------------------------|-----------------------------|-----------------------------|-----------------------------|--|--|---|-------------------------------|
| Also available in 36"                 | 30" Traditional             | 30" Traditional             | 30" Traditional             | 30" Traditional                          | 30" Traditional                                  | 30" High Performance                      | 30" Traditional               |
|                                       |                             |                             | UXT4036AY                   | UXT4236AY                                | UXT5236AY  | UXT5536AA                                 |                               |
| Vertical venting                      | Exterior                    | Exterior                    | Interior                    | <b>Exterior and Interior</b>             | Exterior and Interior                            | Exterior and Interior                     | Exterior                      |
| Horizontal venting                    |                             | <b>Exterior</b>             | Interior                    | <b>Exterior and Interior</b>             | Exterior and Interior                            | Exterior and Interior                     | Exterior                      |
| Type                                  | Top venting only            | <b>Top and rear venting</b> | Recirculating only          | <b>Convertible</b>                       | Convertible                                      | Convertible                               | Vented only                   |
| <b>DUCT TYPE</b>                      |                             |                             |                             |  |  |   |                               |
| 7" Round duct                         | <b>Included</b>             |                             |                             | <b>Included</b>                          | W10355451  |   |                               |
| 3¼" x 10" Rectangular duct            |                             | <b>Included</b>             |                             | <b>Included</b>                          | Included   | Included                                  | Included                      |
| Dishwasher-safe grease filter         | 1                           | 1                           |                             | 1  | 1  | <b>2 (30") or 3 (36")</b>                 | 2                             |
| <b>FEATURES</b>                       |                             |                             |                             |  |  |   |                               |
| ENERGY STAR® qualified                |                             |                             |                             |  |  |   | ♦                             |
| Maximum exhaust (CFM)*                | 190                         | 190                         |                             | <b>225</b>                               | <b>350</b>                                       | <b>400</b>                                | 300                           |
| Sones†                                | up to 4.5                   | <b>up to 5.3</b>            |                             | <b>up to 7</b>                           | <b>up to 9</b>                                   | up to 8.2                                 | up to 7.2 (.32 working speed) |
| Controls                              | 2-speed, rocker switch      | 2-speed, rocker switch      | 2-speed, rocker switch      | <b>Variable speed, rotary</b>            | 3-speed, push-button                             | 3-speed, push-button                      | 3-speed, push-button          |
| Damper                                |                             |                             |                             |  | ♦  |   |                               |
| Fan                                   | Axial                       | Axial                       | Axial                       | Axial                                    | Axial  | <b>Centrifugal</b>                        | Centrifugal                   |
| Lighting                              | 75-watt On/Off incandescent | 75-watt On/Off incandescent | 75-watt On/Off incandescent | <b>75-watt High/Low/Off incandescent</b> | <b>50-watt High/Low halogen (bulbs included)</b> | 50-watt High/Low halogen (bulbs included) | On/Off fluorescent            |
| Recirculation kit/Charcoal filter     |                             |                             | <b>Included</b>             | Optional                                 | Optional   | <b>Included</b>                           |                               |
| Power cord included                   |                             |                             |                             |  |  | ♦   |                               |
| Damper/Vent connector included        | 7" Round                    | 3¼" x 10" Rectangular       |                             | <b>3¼" x 10" Rectangular</b>             | 3¼" x 10" Rectangular                            | 3¼" x 10" Rectangular                     | 3¼" x 10" Rectangular         |
| California Title 24 compliant         | -                           | -                           | N/A                         | -  | -  | -   | -                             |
| <b>ACCESSORIES</b>                    |                             |                             |                             |  |  |   |                               |
| Recirculation kit/Charcoal filter kit |                             |                             | W10355450                   | W10355450                                | W10369358 / W10386873                            | W10272068                                 |                               |
| 7" Round damper                       |                             |                             |                             | W10355451                                | W10355451  |   |                               |
| 7" Damper plate                       |                             |                             |                             | W10388168                                | W10388168  |   |                               |
| Power cord                            | W10355452                   | W10355452                   | W10355452                   | W10355452                                | W10355452  |   |                               |
| <b>DIMENSIONS AND COLORS</b>          |                             |                             |                             |  |  |   |                               |
| Cutout width (A)                      | 30"                         | 30"                         | 30" / 36"                   | 30" / 36"                                | 30" / 36"  | 30" / 36"                                 | 30"                           |
| Minimum mounted height (B)            | 18"                         | 18"                         | 18"                         | 18"                                      | 18"  | 24"                                       | 24" (Electric)<br>27" (Gas)   |
| Height (C)                            | 5"                          | 5"                          | 5"                          | 5"                                       | 5"   | 9"  | 4½"                           |
| Width (D)                             | 29 ⅞"                       | 29 ⅞"                       | 29 ⅞" / 35 ⅞"               | 29 ⅞" / 35 ⅞"                            | 29 ⅞" / 35 ⅞"                                    | 29 ⅞" / 35 ⅞"                             | 29 ⅞"                         |
| Depth (E)                             | 18 ½"                       | 18 ½"                       | 18 ½"                       | 18 ½"                                    | 18 ½"  | 19 ⅞"                                     | 20"                           |
| Cutout depth                          | 11 ⅞"                       | 11 ⅞"                       | 11 ⅞"                       | 11 ⅞"                                    | 11 ⅞"  | 12"                                       |                               |
| Available colors                      | W   B                       | W   B                       | W   B   T*   S*             | W   B   T†   S                           | W††   B††   S                                    | S   | S                             |

Bold type indicates a step-up feature

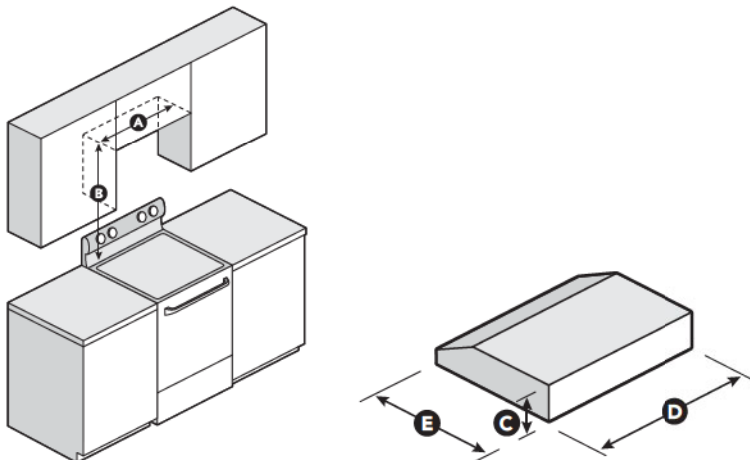

\*Refer to Use & Care Guide for more information. \*\*UXT4030AY only. †UXT4230AY only. ††UXT5230AY only.

DIMENSIONS ARE SHOWN FOR PLANNING PURPOSES ONLY.  
For complete information, see Installation Instructions packed with product.



# Canopy Hoods

## SPECIFICATIONS AND DIMENSIONS

|  | WHIRLPOOL GOLD®                   |                                   | WHIRLPOOL GOLD®                   |                                   | WHIRLPOOL GOLD®                   |                                   | WHIRLPOOL GOLD®                   |
|--|-----------------------------------|-----------------------------------|-----------------------------------|-----------------------------------|-----------------------------------|-----------------------------------|-----------------------------------|
| MODEL  | GXW6530DX                         | UXW6530BS                         | GXI6536DX                         | UXI6536BS                         | GXW7230DA                         | UXW7230BS                         | GXW7330DX                         |
| <b>New 2013 model</b>                          |                                   |                                   |                                   |                                   |                                   |                                   |                                   |
|  | 30" Glass Wall-Mounted Canopy     | 30" Glass Wall-Mounted Canopy     | 36" Glass Island Canopy           | 36" Glass Island Canopy           | 30" Wall-Mounted Canopy           | 30" Wall-Mounted Canopy           | 30" Wall-Mounted Canopy           |
| Also available in 36"                          | GXW6536DX                         | UXW6536BS                         |                                   |                                   |                                   |                                   | GXW7336DX                         |
| Vertical venting Type                          | Exterior and interior Convertible | Exterior and interior Convertible | Exterior and interior Convertible | Exterior and interior Convertible | Exterior and interior Convertible | Exterior and interior Convertible | Exterior and interior Convertible |
| <b>DUCT TYPE</b>                               |                                   |                                   |                                   |                                   |                                   |                                   |                                   |
| Included 6" round duct                         | -                                 | -                                 | -                                 | -                                 | -                                 | -                                 | -                                 |
| Dishwasher-safe grease filter                  | 1                                 | 1                                 | 1                                 | 1                                 | 2                                 | 2                                 | 2                                 |
| <b>FEATURES</b>                                |                                   |                                   |                                   |                                   |                                   |                                   |                                   |
| ENERGY STAR® qualified                         |                                   |                                   |                                   |                                   |                                   |                                   | ♦                                 |
| Maximum exhaust (CFM)*                         | 400                               | 400                               | 400                               | 400                               | 400                               | 400                               | 300                               |
| Sones*   | up to 7.2                         | up to 7.2                         | up to 7.2                         | up to 7.2                         | up to 6.9 (2.4 working speed)     | up to 6.9 (2.4 working speed)     | up to 6 (1.4 working speed)       |
| 3-speed push-button controls                   | -                                 | -                                 | -                                 | -                                 | -                                 | -                                 | -                                 |
| Damper   | -                                 | -                                 | -                                 | -                                 | -                                 | -                                 | -                                 |
| Centrifugal fan                                | -                                 | -                                 | -                                 | -                                 | -                                 | -                                 | -                                 |
| Lighting (bulbs included)                      | On/Off incandescent               | On/Off incandescent               | <b>On/Off halogen</b>             | On/Off halogen                    | On/Off incandescent               | On/Off incandescent               | <b>On/Off fluorescent</b>         |
| Recirculation kit/Charcoal filter              | Optional                          | Optional                          | Optional                          | Optional                          | Optional                          | Optional                          | Optional                          |
| Other accessories                              | Chimney extension kit             | Chimney extension kit             | Chimney extension kit             | Chimney extension kit             | Chimney extension kit             | Chimney extension kit             | Chimney extension kit             |
| <b>DIMENSIONS AND COLORS</b>                   |                                   |                                   |                                   |                                   |                                   |                                   |                                   |
| A  | 13 7/16"                          | 13 7/16"                          | 13 7/16"                          | 13 7/16"                          | 8 1/8"                            | 8 1/8"                            | 8 1/8" / 8 1/16"                  |
| B  | 10 1/8"                           | 10 1/8"                           | 12 1/4"                           | 12 1/4"                           | 7 1/4"                            | 7 1/4"                            | 7 1/4" / 7 1/8"                   |
| Recirculating height (C)                       | 27 7/8"–45 1/2"                   | 27 7/8"–45 1/2"                   | 29 3/4"–49 9/16"                  | 29 3/4"–49 9/16"                  | 28 1/8"–42 1/8"                   | 28 1/8"–42 1/8"                   | 28 1/8"–42 1/8"                   |
| Vented height (C)                              | 27 7/8"–41 1/8"                   | 27 7/8"–41 1/8"                   | 29 3/4"–44 9/16"                  | 29 3/4"–44 9/16"                  | 28 3/8"–38"                       | 28 3/8"–38"                       | 28 3/8"–38"                       |
| Width (D)                                      | 30" / 36"                         | 30" / 36"                         | 36"                               | 36"                               | 30"                               | 30"                               | 30" / 36"                         |
| Depth (E)                                      | 20"                               | 20"                               | 25 3/8"                           | 25 3/8"                           | 20"                               | 20"                               | 20"                               |
| Minimum mounted height (above cooking surface) | 24" (Electric)<br>27" (Gas)       | 24" (Electric)<br>27" (Gas)       | 24" (Electric)<br>27" (Gas)       | 24" (Electric)<br>27" (Gas)       | 24" (Electric)<br>27" (Gas)       | 24" (Electric)<br>27" (Gas)       | 24" (Electric)<br>27" (Gas)       |
| Available colors                               | S                                 | S                                 | S                                 | S                                 | S                                 | S                                 | S                                 |

Bold type indicates a step-up feature

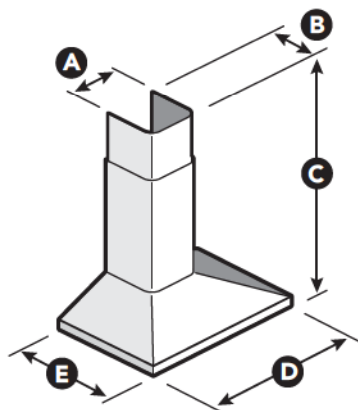

\*Refer to Use & Care Guide for more information.

DIMENSIONS ARE SHOWN FOR PLANNING PURPOSES ONLY.  
For complete information, see Installation Instructions packed with product.

# Downdraft Vent

## SPECIFICATIONS AND DIMENSIONS

| MODEL                          | UXD8630DY                |
|--------------------------------|--------------------------|
| Also available in 36"          | 30" Pop-Up Downdraft     |
| Vertical venting               | UXD8636DY                |
| Horizontal venting             | Exterior                 |
| Type                           | Exterior                 |
|                                | Vented only              |
| DUCT TYPE                      |                          |
| 6" Round duct                  | Included                 |
| 3 1/4" x 10" Rectangular duct  | Included                 |
| Dishwasher-safe grease filter  | 2                        |
| FEATURES                       |                          |
| Maximum exhaust (CFM)*         | 600                      |
| Sones*                         | up to 7.9                |
| Controls                       | 4-speed slider           |
| Damper                         | -                        |
| Fan                            | Dual centrifugal         |
| Damper/Vent connector included | 3 1/4" x 10" Rectangular |
| DIMENSIONS AND COLORS          |                          |
| A                              | 10"                      |
| B                              | 13 7/8"                  |
| C                              | 16 1/2"                  |
| D                              | 27" / 33"                |
| E                              | 2 1/8"                   |
| F                              | 28 1/2"                  |
| G                              | 30" / 36"                |
| Available colors               | S                        |

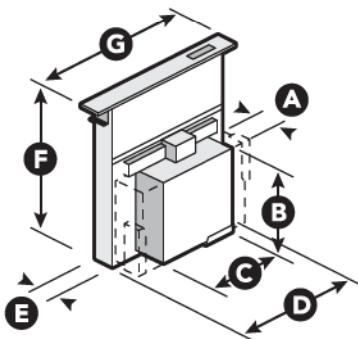

\*Refer to Use & Care Guide for more information.

DIMENSIONS ARE SHOWN FOR PLANNING PURPOSES ONLY.  
For complete information, see Installation Instructions packed with product.

# Hood Liners

## SPECIFICATIONS AND DIMENSIONS

| MODEL                                 | UXL5430BS                                  | UXL6036YS  | UXL6048YS  |
|---------------------------------------|--|--|--|
| Vertical venting                      | 30"  | 36" Under Cabinet  | 48" Under Cabinet  |
| Type                                  | Convertible                                | Vented   | Vented   |
| <b>DUCT TYPE</b>                      |  |  |  |
| 10" Round duct                        | -  | ♦  | -  |
| 6" Round duct                         | -  | -  | -  |
| <b>FEATURES</b>                       |  |  |  |
| Auto-On Heat sensor                   | -  | ♦  | -  |
| Controls                              | 3-speed, push button                       | 3-speed, <b>slider</b>   | 3-speed, slider  |
| Lighting                              | 2, 50-watt On/Off halogen (bulbs included) | <b>4</b> , 50-watt <b>High/Low</b> halogen (bulbs included)  | 4, 50-watt High/Low halogen (bulbs included)   |
| Dishwasher-safe grease filter         | 2  | <b>3</b>   | <b>4</b>   |
| <b>ACCESSORIES</b>                    |  |  |  |
| Blower motor systems                  | Included 400 CFM                           | Internal 600 CFM - UXB0600DYS<br>Internal 1200 CFM - UXB1200DYS<br>In-Line 600 CFM - UXI0600DYS<br>In-Line 1200 CFM - UXI1200DYS | Internal 600 CFM - UXB0600DYS<br>Internal 1200 CFM - UXB1200DYS<br>In-Line 600 CFM - UXI0600DYS<br>In-Line 1200 CFM - UXI1200DYS |
| Recirculation/Charcoal filter kit     | W10490330                                  | N/A  | N/A  |
| Face panel rear extension (30" x 18") | W10490327                                  | N/A  | N/A  |
| Face panel (36" x 18")                | W10490310                                  | N/A  | N/A  |
| <b>DIMENSIONS AND COLORS</b>          |  |  |  |
| Height                                | 13 <sup>5</sup> / <sub>8</sub> "           | 11 <sup>1</sup> / <sub>2</sub> "   | 11 <sup>1</sup> / <sub>2</sub> "   |
| Width                                 | 30"  | 35 <sup>7</sup> / <sub>8</sub> "   | 47 <sup>7</sup> / <sub>8</sub> "   |
| Depth                                 | 11 <sup>1</sup> / <sub>4</sub> "           | 22"  | 22"  |
| Available colors                      | S  | S  | S  |

Bold type indicates a step-up feature





## DISHWASHERS

- 160 Built-in dishwashers
- 166 Compact dishwasher
- 167 Portable dishwasher
- 168 Food disposers
- 170 Trash compactors
- 172 Accessories
- 174 Glossary
- 176 Specifications





## DISHWASHERS



### **Takes the guesswork out of doing dishes**

The Sensor cycle automatically selects the right wash and dry settings using two sensors that measure temperature, soil level and load size. It cleans tough soils 35% better\* using the right amount of time, energy and water.



### **Makes washing large items easy**

With features like the EZ-2-Lift™ adjustable upper rack and EZ Adjustable tines, you'll be able to take advantage of the large 15 place-setting capacity available on select Whirlpool® dishwashers.



### **Cleans without soaking or scrubbing**

The enhanced PowerScour™ option uses 40 targeted spray jets in a designated wash area to scour away baked-on foods and deliver twice the coverage to clean your large pots and pans.



### **Uses less water and energy without compromising performance\*\***

Not only do Whirlpool brand dishwashers use less water and energy to meet the CEE Tier 1† standard, but no one has fewer repairs 17 years in a row.†† Using our innovative resource-efficient wash system, these ENERGY STAR® qualified models will even save money on utility bills.

NOTE: Not all features are available on all models.

\*Compared to previous wash system. \*\*Compared to a conventional dishwasher manufactured before 2006. †Based on the Consortium for Energy Efficiency qualifying product lists. Visit [ceef.org](http://ceef.org) for more information. ††According to a leading consumer magazine.

## Dishwashers



### **WDF310PAA W | B | T | D | S**

ENERGY STAR® qualified  
Meets CEE Tier 1\* standards  
In-the-Rack silverware basket  
Resource-efficient wash system  
Quiet Partner™ I sound package  
6" Console with electronic controls  
White plastic tall tub



### **WDF510PAY W | B | D | S**

AnyWare™ Plus silverware basket  
Quiet Partner™ II sound package  
4" Console with electronic controls  
ENERGY STAR® qualified  
Meets CEE Tier 1\* standards  
Resource-efficient wash system  
White plastic tall tub

\*Based on the Consortium for Energy Efficiency qualifying product lists. Visit [cee1.org](http://cee1.org) for more information.

Step-up features  
highlighted by  
yellow bar



Most Whirlpool® dishwashers  
are ENERGY STAR® qualified.

## Dishwashers



### **WDF530PAY W | B | T | M**

- 2½" Sleek console with electronic controls
- Slate plastic tall tub
- ENERGY STAR® qualified
- Meets CEE Tier 1\* standards
- AnyWare™ Plus silverware basket
- Resource-efficient wash system
- Quiet Partner™ II sound package



### **WDF550SAA W | B | S**

- Stainless steel tall tub
- ADA height and reach compliant\*\*
- ENERGY STAR® qualified
- Meets CEE Tier 1\* standards
- In-the-Rack silverware basket
- Resource-efficient wash system
- Quiet Partner™ I sound package
- 5" Console with electronic controls

\*Based on the Consortium for Energy Efficiency qualifying product lists. Visit [cee1.org](http://cee1.org) for more information. \*\* Meets ADA height and reach requirements and must be installed in compliance with ADA Standards.

Feature descriptions can be found in the glossary on pages 174–175. Complete product specifications can be found on page 176.

## Dishwashers



### WDT710PAY W | B | M | H | E

- Whirlpool Gold® model
- Sensor cycle
- AnyWare™ Plus silverware basket
- Adjustable upper rack
- Quiet Partner™ II sound package
- Fully integrated electronic controls
- ENERGY STAR® qualified
- Meets CEE Tier 1\* standards
- Resource-efficient wash system
- Slate plastic tall tub



### WDF750SAY W | B | M

- Whirlpool Gold® model
- Quiet Partner™ IV sound package
- Stainless steel tall tub
- Sensor cycle
- ENERGY STAR® qualified
- Meets CEE Tier 1\* standards
- AnyWare™ Plus silverware basket
- Resource-efficient wash system
- 2½" Sleek console with electronic controls



\*Based on the Consortium for Energy Efficiency qualifying product lists. Visit [cee1.org](http://cee1.org) for more information.

Step-up features highlighted by yellow bar



Most Whirlpool® dishwashers are ENERGY STAR® qualified.



## Dishwashers



### WDT790SAY W | B | M

Whirlpool Gold® model

Adjustable upper rack

Fully integrated electronic controls

Sensor cycle

ENERGY STAR® qualified

Meets CEE Tier 1\* standards

AnyWare™ Plus silverware basket

Resource-efficient wash system

Quiet Partner™ IV sound package

Stainless steel tall tub



### WDT910SAY M | H | E

Whirlpool Gold® model

PowerScour™ option

EZ Adjustable tines

EZ-2-Lift™ adjustable upper rack

Sensor cycle

ENERGY STAR® qualified

Meets CEE Tier 1\* standards

AnyWare™ Plus silverware basket

Resource-efficient wash system

Quiet Partner™ IV sound package

Fully integrated electronic controls

Stainless steel tall tub

\*Based on the Consortium for Energy Efficiency qualifying product lists. Visit [cee1.org](http://cee1.org) for more information.

Feature descriptions can be found in the glossary on pages 174–175. Complete product specifications can be found on page 177.

## Compact Dishwasher



### **WDF518SAA W | B | M**

- ENERGY STAR® qualified
- In-the-Rack silverware basket
- Resource-efficient wash system
- Quiet Partner™ I sound package
- 5" Console with electronic controls
- Stainless steel tall tub



Most Whirlpool® dishwashers are ENERGY STAR® qualified.

## Portable Dishwasher



### **WDP350PAA W | B**

- ENERGY STAR® qualified
- In-the-Rack silverware basket
- Resource-efficient wash system
- Quiet Partner™ I sound package
- Electronic controls
- White plastic tall tub

---

Feature descriptions can be found in the glossary on pages 174–175. Complete product specifications can be found on pages 178–179.

## Food Disposers



### GC1000XE/PE\*

- 1/3-HP motor
- Locked-in mounting
- Continuous-feed operation
- Overload protector
- Manual reset



### GC2000XE/PE\*

- 1/2-HP motor
- Locked-in mounting
- Continuous-feed operation
- Overload protector
- Manual reset

\*Also available with plug and cord.

Step-up features  
highlighted by  
yellow bar

## Food Disposers



### **GC5000XE**

- ¾-HP motor
- Stainless steel grinding wheel
- Sound insulation
- Locked-in mounting
- Continuous-feed operation
- Overload protector
- Manual reset

---

Feature descriptions can be found in the glossary on pages 174–175. Complete product specifications can be found on page 180.



## Trash Compactors



### **GX900QPP 1.4 cu. ft. Q | B | S**

- Whirlpool Gold® model
- 1/3-HP motor
- Touch pad controls
- Clean Touch™ console
- Under counter
- Touch-Toe™ drawer opener
- Easy Rollers™ installation wheels
- Tilt-Away trash basket



### **GC900QPP 1.4 cu. ft. Q | B**

- Whirlpool Gold® model
- Convertible freestanding-to-built-in**
- 1/3-HP motor
- Touch pad controls
- Clean Touch™ console
- Touch-Toe™ drawer opener
- Easy Rollers™ installation wheels
- Tilt-Away trash basket

Step-up features  
highlighted by  
yellow bar

## Trash Compactors



### **TU950QPX 1.4 cu. ft. S**

Fully integrated controls

Under counter

1/3-HP motor

Touch-Toe™ drawer opener

Easy Rollers™ installation wheels

---

Feature descriptions can be found in the glossary on pages 174–175. Complete product specifications can be found on page 181.

## Accessories



### Small Items Basket (3370993RB)

Fits all Whirlpool® dishwashers. It holds baby items, jar lids and other small utensils that would normally slip through the dishwasher rack.



### Swivel Gooseneck Fitting (W10574777)

Space-saving 90° design makes this 3/4" x 3/8" elbow hose fitting perfect for easy dishwasher installation. A 3/8" brass compression fitting is included. Required on dishwashers produced after 2009.



### 12' Drain Hose (Tall Tub-3385556) 12' Drain Hose (NEW-8531858) 6' Drain Hose (8269144A)

This flexible drain hose for tall tub dishwasher models offers a no-kink design made for hot water.



### Small Items Bag (8519716)

Holds extra-small utensils, contact cases and other small items that would normally slip through the dishwasher rack.



### 6', 3-Prong Dishwasher Power Supply Kit (W10278923RP)

This straight, 6', 90° UL-listed power cord kit fits dishwashers from most major brands and includes a power cord, metal strain relief bracket, wire nuts and instructions.



### Undercounter Mounting Kit (W10426979)

Works with all standard size dishwashers. Can be used with solid surfaces, including granite.



### NEW! affresh® Disposal cleaner (W10509526)

Foaming action works to loosen food and organic material to clean and deodorize. Carton contains 4 tablets.



### affresh® Dishwasher Cleaner (W10282479)

Powers away hard water mineral residue and is Designed for the Environment.\* Pouch contains 6 tablets.



### Dishwasher Rack Repair Kit White: 4396838RC Black: 4396839RC Grey: 4396840RC

This kit has everything you need to repair your dishwasher rack tines. It contains 150 tine tips, a 4-oz bottle of vinyl touch-up paint/adhesive with a brush and instruction sheet.



### 5', 3-Prong Dishwasher Power Cord (4317824)

Take home everything you need to bring power to your dishwasher with the UL-listed power cord, strain relief, wire nuts and installation instructions.

To acquire pricing information, order Whirlpool® dishwasher accessories and determine delivery time, visit [whirlpool.com/accessories](http://whirlpool.com/accessories) or call 1-800-462-3819.

\*Visit [epa.gov/dfe](http://epa.gov/dfe) for more information.

# Accessories

## Mounting Kits

| MODEL                                 | WDF310PAA | WDF510PAY | WDF530PAY | WDT710PAY |
|---------------------------------------|-----------|-----------|-----------|-----------|
| Side mounting kit (plastic tubs only) | 8212560   | 8212560   | 8212560   | 8212560   |
| Tall tub floor mounting kit           | 4378968   | 4378968   | 4378968   | 4378968   |

| MODEL              | WDF750SAY    | WDT790SAY    | WDT910SAY    |
|--------------------|--------------|--------------|--------------|
| Floor mounting kit | 8171477**    | 8171477**    | 8171477**    |
| Side mounting kit  | Not required | Not required | Not required |

## Hoses and Cords

Reinforced hoses include one of each of the following:  
 3/8" brass elbow, 3/8" brass compression fitting  
 and 3/8" brass swivel gooseneck fitting.

| AVAILABLE ACCESSORY                    |             |
|--|-------------|
| 4' Red EPDM hose                       | W10278625RP |
| 5' Red EPDM hose                       | W10278626RP |
| 6' Red EPDM hose (retail polybag)      | W10278627RP |
| 6' Braided hose (without teflon tape)  | W10278635RP |
| 6' Red EPDM hose (retail claim)        | W10278627RC |
| 6' Braided hose (with teflon tape)     | W10278636RC |
| 6' 3-prong dishwasher power supply kit | W10278923RP |

## Dishwasher Panels and Optional Accessory Kits

| MODEL                | WDF510PAY  |
|----------------------|--|
| 4" Console trim kit† | White - 4396200<br>Black - 4396199<br>Biscuit - 4396201                              |
| Side panel kit       | White - 8171656<br>Black - 8171657<br>Biscuit - 8171658<br>Stainless Steel - 8171659 |

\*\*Stainless steel tall tub models only. †Trim Kit accommodates both a framed and frameless custom panel design.  
 6" custom panels for models WDF310PAA and WDF350PAA are not available at this time.

# Glossary

## 1-Hour Wash cycle

Thoroughly cleans your dishes in nearly half the time.\* This hour-long cycle helps you take care of dirty dishes when you are in a rush.

## ADA height and reach compliant

Select dishwashers with this designation meet ADA height and reach requirements and must be installed in compliance with Americans with Disabilities Act Standards.

## Adjustable upper rack

Manually raise or lower the upper rack to better fit tall items.

## AnyWare™ Plus silverware basket

Designed to clean better and fit in four places for maximum flexibility, the AnyWare™ Plus silverware basket rests on two locations in the bottom rack, the front of the lower rack or in the door for 100% usable rack space.

## Auto soil sensor

Optimizes every cycle for reliable cleaning results. This sensor measures water clarity to determine how dirty dishes are, then adjusts the cycle accordingly. It measures the soils in the water and will add extra water and adapt temperature to ensure clean dishes.

## CEE Tier standards

Based on the Consortium for Energy Efficiency (CEE) qualifying product lists—with the Tier 1 standard being the most efficient. Visit [cee1.org](http://cee1.org) for more information.

## Clean & Quiet Guarantee

If you are not completely satisfied that your new Whirlpool Gold® dishwasher is quieter and cleans better than your previous model, Whirlpool Corporation will take it back within 30 days of the date of purchase and refund the full price to you. Visit [whirlpool.com](http://whirlpool.com) for complete details and qualified models.

## Clean Touch™ console

Select Whirlpool® trash compactors feature a smooth console with no dials or switches that cleans easily.

## Control lock

Disables buttons on the control pad to help prevent accidental operation or children from starting or stopping the dishwasher.

## Cup shelf

Allows you to stack two levels of coffee mugs or small cups and to secure delicate glassware when used as a stemware holder in the upper rack.

## Delay Wash option

Wash dishes according to your schedule. This option lets you delay washing for up to 8 hours until off-peak hours when utility rates may be lower.

## Easy Rollers™ installation wheels

Easily position your Whirlpool® compactor where you need it with the Easy Rollers™ installation wheels.

## Eco Dry option

The industry's first Eco Dry option is the most efficient drying option on our dishwashers\*\* because it uses 70% less energy compared to using Heated Dry.

## Eco Wash cycle

Our most efficient dishwasher cycle helps minimize energy and water usage while cleaning dishes.\*\* It is great for cleaning lightly to moderately soiled dishes.

## ENERGY STAR® qualified

Exceeds government standards to help conserve natural resources and save money on utility bills.

## EZ-2-Lift™ adjustable upper rack

Easily adjust the upper rack 2" up or down to fit larger items in either rack. Improved to allow for 100% usable upper rack space, our easiest to adjust rack can be lifted or lowered to accommodate different size items and features narrow profile adjusters that don't interfere with loading.

## EZ Adjustable tines

Innovative sliding lower-rack tines move left or right to fit your dishes. Now you have twice the space between tines to fit larger bowls for optimal cleaning.

## Fold-down tines

Secure dishes during the wash cycle or fold down to create space for larger items.

## Fully integrated controls

Add a modern accent to your kitchen with a control panel that's hidden away and provides a sleek exterior while preventing unwanted cycle changes or accidental operation.

## Heavy cycle

Adds more time to the cycle to clean heavily soiled items.

NOTE: Not all features are available on all models.

\*Compared to Normal cycle with lightly soiled loads. \*\*Available on Whirlpool® models MSRP \$449 and above.



# Glossary

## High Temperature Wash option

Choose this option when additional cleaning of items like baby bottles, glassware or dishes is required.

## Light item clips

Secure lightweight items during the wash cycle and help prevent items from falling out of the rack. They also stop cups and other small containers from flipping over and filling with water.

## Normal cycle

Use for loads with normal amounts of food soil. This cycle is great for everyday loads.

## Nylon racks

Durable nylon coating helps resist rust and prevent scratching.

## Overnight cycle

This industry-exclusive cycle quietly soaks your dishes with an extended prewash and then runs a tough soil wash to clean dirty dishes.

## PowerScour™ option

The PowerScour™ option uses 40 targeted spray jets in a designated wash area to scour away baked-on foods without soaking or scrubbing. From casserole dishes to pots and pans, this option delivers twice the coverage to clean large items.

## Quiet Partner™ sound packages

Whirlpool brand dishwashers offer many levels of sound-reducing insulation. The Quiet Partner™ IV sound package is the highest available.

## Resource-efficient wash system

Efficiently cleans a full load of dishes using nearly half the water and energy.<sup>†</sup> This system provides excellent cleaning first in the upper rack, then the lower, to reduce the amount of water used.

## Sani Rinse option

Sanitizes dishes by eliminating 99.999% of food soil and bacteria.

## Sensor cycle

Automatically selects the right wash and dry settings for your load by using two separate sensors to measure temperature, soil level and load size once during the prewash and once during the wash cycle. It cleans tough soils 35% better<sup>††</sup> using just the right amount of time, energy and water.

## SheerClean™ wash system

Channels water up and out of the back and top of the dishwasher to powerfully clean from multiple angles. The filter keeps wash water clean and delivers sparkling-clean dishes.

## Slate interior

Reduces the appearance of visible tub stains, wash after wash. Sophisticated slate styling gives the dishwasher an attractive, premium look.

## Soak & Scour option

Gently soaks, powerfully cleans and then soaks again to remove tough soils from dishes so you don't have to.

## Stainless steel interior

Retains heat from wash and rinse cycles to promote drying. The stainless steel interior also cools faster than the dishes, allowing moisture to condense on the interior walls and drawing additional water off the hotter dishes.

## Tall tub design

Allows you to load tall and odd-shaped items in both racks. An additional 3" of interior space compared to standard tub models makes room for extra-large items in the lower rack and plates or sports bottles in the upper rack.

## Top Rack Wash option

Save time and energy with the Top Rack Wash option. It washes the top rack of dishes, so you don't have to wait for a full load to wash a few items.

## Touch-Toe™ drawer opener

Easily open Whirlpool® trash compactors without your hands using the Touch-Toe™ drawer opener. A light tap of the toe is all that's needed to release the drawer.

---

NOTE: Not all features are available on all models.

<sup>†</sup>Compared to dishwashers manufactured before 2006. <sup>††</sup>Compared to previous wash system.

# Dishwashers

## SPECIFICATIONS AND DIMENSIONS

|  | WHIRLPOOL®                  |                              |                              |                             |
|--|-----------------------------|------------------------------|------------------------------|-----------------------------|
| MODEL  | WDF310PAA                   | WDF510PAY                    | WDF530PAY                    | WDF550SAA                   |
| Place setting capacity                           | 12                          | 14                           | 15                           | 12                          |
| ENERGY STAR® qualified                           | -                           | -                            | -                            | -                           |
| Meets CEE Tier standards*                        | Tier 1                      | Tier 1                       | Tier 1                       | Tier 1                      |
| Tall tub design                                  | -                           | -                            | -                            | -                           |
| Tub material                                     | Plastic – White             | Plastic – White              | Plastic – Slate              | Stainless steel             |
| Sound package                                    | Quiet Partner™ I (59 dBA**) | Quiet Partner™ II (55 dBA**) | Quiet Partner™ II (55 dBA**) | Quiet Partner™ I (54 dBA**) |
| ADA height and reach compliant†                  | -                           | -                            | -                            | ♦                           |
| Designed, engineered and assembled in the U.S.A. | -                           | -                            | -                            | -                           |
| <b>WASH SYSTEM</b>                               |                             |                              |                              |                             |
| Resource-efficient wash system                   | -                           | -                            | -                            | -                           |
| Auto soil sensor                                 | -                           | -                            | -                            | -                           |
| Console height                                   | 6"                          | 4"                           | 2½"                          | 5"                          |
| Electronic controls                              | -                           | -                            | -                            | -                           |
| 5-level direct-feed                              | -                           | -                            | ♦                            | -                           |
| 4-level direct-feed                              | -                           | -                            | -                            | -                           |
| <b>CYCLES</b>                                    |                             |                              |                              |                             |
| Total number of cycles                           | 3                           | 5                            | 5                            | 5                           |
| Eco Wash   | -                           | ♦                            | -                            | -                           |
| Overnight  | -                           | ♦                            | -                            | -                           |
| 1-Hour Wash                                      | -                           | -                            | -                            | -                           |
| Pots & Pans                                      | -                           | -                            | -                            | ♦                           |
| Heavy  | -                           | -                            | -                            | -                           |
| Normal   | -                           | -                            | -                            | -                           |
| Light  | -                           | -                            | -                            | ♦                           |
| Rinse Only                                       | -                           | -                            | -                            | ♦                           |
| <b>OPTIONS</b>                                   |                             |                              |                              |                             |
| Total number of options                          | 4                           | 4                            | 6                            | 4                           |
| Eco Dry  | -                           | -                            | ♦                            | -                           |
| Heated Dry                                       | -                           | -                            | -                            | -                           |
| Sani Rinse                                       | -                           | ♦                            | -                            | -                           |
| High Temperature Wash                            | -                           | -                            | -                            | -                           |
| Delay Wash                                       | 4 Hour                      | 4 Hour                       | 2-4-8 Hour                   | 2-4-6 Hour                  |
| Control lock                                     | -                           | -                            | ♦                            | -                           |
| <b>RACK FLEXIBILITY</b>                          |                             |                              |                              |                             |
| Rack coating                                     | Vinyl                       | Vinyl                        | Nylon                        | Nylon                       |
| Light item clips                                 | -                           | -                            | 2                            | -                           |
| Cup shelves                                      | -                           | -                            | ♦                            | -                           |
| Silverware basket                                | In-the-Rack                 | AnyWare™ Plus                | AnyWare™ Plus                | In-the-Rack                 |
| <b>DIMENSIONS AND COLORS</b>                     |                             |                              |                              |                             |
| Height (A)                                       | 33½"-34½"                   | 33½"-34½"                    | 33½"-34½"                    | 32½"-34½"                   |
| Width (B)  | 23½"                        | 23½"                         | 23½"                         | 24"                         |
| Depth (C)  | 24½"                        | 24½"                         | 24½"                         | 24"                         |
| Minimum cutout height (D)                        | 34"                         | 34"                          | 34"                          | 34"                         |
| Cutout width (E)                                 | 24"                         | 24"                          | 24"                          | 24"                         |
| Cutout depth (F)                                 | 24"                         | 24"                          | 24"                          | 24"                         |
| Available colors                                 | W   B   T   D   S           | W   B   D   S                | W   B   T   M                | W   B   S                   |

Bold type indicates a step-up feature

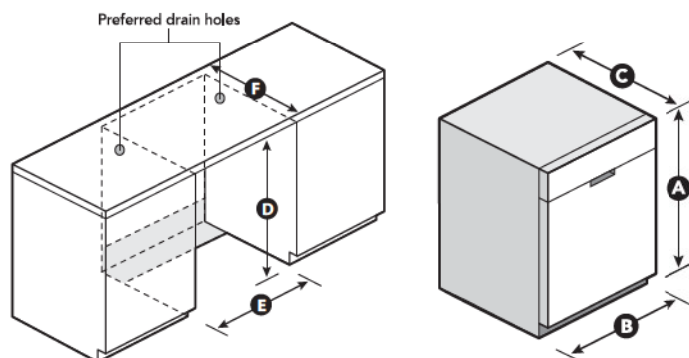

\*Based on the Consortium for Energy Efficiency qualifying product lists. Visit [cee1.org](http://cee1.org) for more information.  
 \*\*Per IEC standards. †Meets ADA height and requirements and must be installed in compliance with ADA Standards.

DIMENSIONS ARE SHOWN FOR PLANNING PURPOSES ONLY.  
 For complete information, see Installation Instructions packed with product.

# Dishwashers

## SPECIFICATIONS AND DIMENSIONS

|  | WHIRLPOOL GOLD*              |                              |                              |                              |
|--|------------------------------|------------------------------|------------------------------|------------------------------|
| MODEL  | WDT710PAY                    | WDF750SAY                    | WDT790SAY                    | WDT910SAY                    |
| Place setting capacity                             | 15                           | 15                           | 15                           | 15                           |
| ENERGY STAR® qualified                             | -                            | -                            | -                            | -                            |
| Meets CEE Tier standards†                          | Tier 1                       | Tier 1                       | Tier 1                       | Tier 1                       |
| Tall tub design                                    | -                            | -                            | -                            | -                            |
| Tub material                                       | Plastic – Slate              | Stainless steel              | Stainless steel              | Stainless steel              |
| Sound package                                      | Quiet Partner™ II (55 dBA**) | Quiet Partner™ IV (51 dBA**) | Quiet Partner™ IV (51 dBA**) | Quiet Partner™ IV (51 dBA**) |
| 30-Day Clean & Quiet guarantee††                   | ♦                            | -                            | -                            | -                            |
| Designed, engineered and assembled in the U.S.A.   | -                            | -                            | -                            | -                            |
| <b>DISHWASHER SYSTEM</b>                           |                              |                              |                              |                              |
| 5-level direct-feed Resource-efficient wash system | -                            | -                            | -                            | -                            |
| Auto soil sensor                                   | ♦                            | -                            | -                            | -                            |
| Console height                                     | Fully integrated             | 2½"                          | Fully integrated             | Fully integrated             |
| Electronic controls                                | -                            | -                            | -                            | -                            |
| <b>CYCLES</b>                                      |                              |                              |                              |                              |
| Total number of cycles                             | 6                            | 5                            | 6                            | 6                            |
| Sensor   | ♦                            | -                            | -                            | -                            |
| Eco Wash   | -                            | -                            | -                            | -                            |
| Overnight  | -                            | -                            | ♦                            | -                            |
| 1-Hour Wash  | -                            | -                            | -                            | -                            |
| Heavy  | -                            | -                            | -                            | -                            |
| Normal   | -                            | -                            | -                            | -                            |
| <b>OPTIONS</b>                                     |                              |                              |                              |                              |
| Total number of options                            | 7                            | 6                            | 7                            | 7                            |
| Eco Dry  | ♦                            | -                            | -                            | -                            |
| Heated Dry   | -                            | -                            | -                            | -                            |
| Top Rack Wash                                      | ♦                            | -                            | ♦                            | -                            |
| PowerScour™  | -                            | -                            | -                            | ♦                            |
| Sani Rinse   | ♦                            | -                            | -                            | -                            |
| High Temperature Wash                              | -                            | -                            | -                            | -                            |
| Delay Wash   | 4 Hour                       | 2-4-8 Hour                   | 4 Hour                       | 4 Hour                       |
| Control lock                                       | -                            | -                            | -                            | -                            |
| <b>RACK FLEXIBILITY</b>                            |                              |                              |                              |                              |
| Nylon rack coating                                 | -                            | -                            | -                            | -                            |
| Adjustable upper rack                              | ♦                            | -                            | ♦                            | EZ-2-Lift™                   |
| Light item clips                                   | 2                            | 2                            | 2                            | 2                            |
| Cup shelves  | -                            | -                            | -                            | -                            |
| EZ Adjustable tines                                | -                            | -                            | -                            | ♦                            |
| 2 Upper rack fold-down tines                       | ♦                            | -                            | -                            | ♦                            |
| Lower rack fold-down tines                         | -                            | -                            | -                            | ♦                            |
| AnyWare™ Plus silverware basket                    | ♦                            | -                            | -                            | -                            |
| Premium rail system                                | -                            | -                            | -                            | ♦                            |
| <b>DIMENSIONS AND COLORS</b>                       |                              |                              |                              |                              |
| Height (A)   | 33½"-34½"                    | 33½"-34½"                    | 33½"-34½"                    | 33½"-34½"                    |
| Width (B)  | 23½"                         | 23½"                         | 23½"                         | 23½"                         |
| Depth (C)  | 24½"                         | 24½"                         | 24½"                         | 24½"                         |
| Minimum cutout height (D)                          | 34"                          | 34"                          | 34"                          | 34"                          |
| Cutout width (E)                                   | 24"                          | 24"                          | 24"                          | 24"                          |
| Cutout depth (F)                                   | 24"                          | 24"                          | 24"                          | 24"                          |
| Available colors                                   | W   B   M   H   E            | W   B   M                    | W   B   M                    | M   H   E                    |

Bold type indicates a step-up feature



### Electrical requirements

Rated load is 11.0 amps, 120 volts, 60 Hz AC.  
15-amp (20-amp max) circuit required.

When local codes permit, any Whirlpool® dishwasher plus a disposer up to 7.2 amps can be installed on a single 20-amp circuit. Do not use an extension cord.

Water Pressure — 15 to 120 psi.

Recommended incoming water temperature — 120°F minimum.

Listed by Underwriters Laboratories.

\*Based on the Consortium for Energy Efficiency qualifying product lists. Visit [cee1.org](http://cee1.org) for more information. \*\*Per IEC standards. ††Visit [whirlpool.com](http://whirlpool.com) for complete details and qualified models.

DIMENSIONS ARE SHOWN FOR PLANNING PURPOSES ONLY.  
For complete information, see Installation Instructions packed with product.

# Compact Dishwasher

## SPECIFICATIONS AND DIMENSIONS

| WHIRLPOOL®   |                            |
|--|----------------------------|
| <b>MODEL</b>                                       | <b>WDF518SAA</b>           |
| Place setting capacity                             | 8                          |
| ENERGY STAR® qualified                             | -                          |
| Tall tub design                                    | -                          |
| Tub material                                       | Stainless steel            |
| Sound package                                      | Quiet Partner™ I (57 dBA*) |
| <b>WASH SYSTEM</b>                                 |                            |
| 4-level direct-feed Resource-efficient wash system | -                          |
| Console height                                     | 5"                         |
| Electronic controls                                | -                          |
| <b>CYCLES</b>                                      |                            |
| Total number of cycles                             | 5                          |
| Pots & Pans  | -                          |
| Heavy  | -                          |
| Normal   | -                          |
| Quick Wash   | -                          |
| Rinse Only   | -                          |
| <b>OPTIONS</b>                                     |                            |
| Total number of options                            | 2                          |
| Heated Dry   | -                          |
| Delay Wash   | 2-4-8 Hour                 |
| <b>RACK FLEXIBILITY</b>                            |                            |
| Vinyl rack coating                                 | -                          |
| Cup shelves  | -                          |
| Silverware basket                                  | In-the-Rack                |
| <b>DIMENSIONS AND COLORS</b>                       |                            |
| Height (A)   | 32 1/2"-35"                |
| Width (B)  | 17 1/2"-18"                |
| Depth (C)  | 22"                        |
| Minimum cutout height (D)                          | 34"                        |
| Cutout width (E)                                   | 17 1/8"-18"                |
| Cutout depth (F)                                   | 24"                        |
| Available colors                                   | W   B   M                  |



### Electrical requirements

Rated load is 11.0 amps, 120 volts, 60 Hz AC.

15-amp (20-amp max) circuit required.

When local codes permit, any Whirlpool® dishwasher plus a disposer up to 7.2 amps can be installed on a single 20-amp circuit. Do not use an extension cord.

Water Pressure — 15 to 120 psi.

Recommended incoming water temperature — 120°F minimum.

Listed by Underwriters Laboratories.

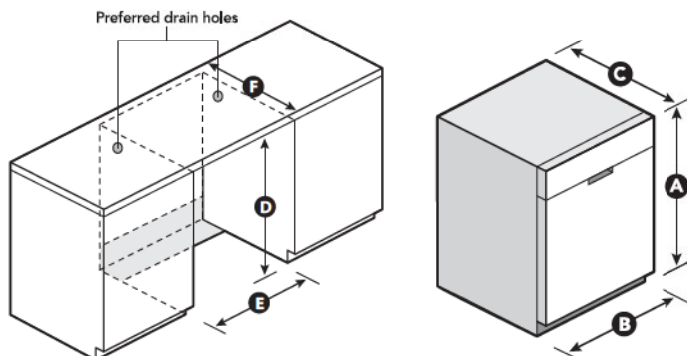

\*Per IEC standards.

# Portable Dishwasher

## SPECIFICATIONS AND DIMENSIONS

| WHIRLPOOL®                                       |                            |
|--|----------------------------|
| MODEL  | WDP350PAA                  |
| Place setting capacity                           | 12                         |
| ENERGY STAR® qualified                           | -                          |
| Tall tub design                                  | -                          |
| Tub material                                     | White plastic              |
| Sound package                                    | Quiet Partner™ I (63 dBA*) |
| Designed, engineered and assembled in the U.S.A. | -                          |
| WASH SYSTEM                                      |                            |
| 4-level Resource-efficient wash system           | -                          |
| Electronic controls                              | -                          |
| CYCLES   |                            |
| Total number of cycles                           | 3                          |
| Heavy  | -                          |
| 1-Hour Wash                                      | -                          |
| Normal   | -                          |
| OPTIONS  |                            |
| Total number of options                          | 4                          |
| Heated Dry                                       | -                          |
| High Temperature Wash                            | -                          |
| Delay Wash                                       | 4 Hour                     |
| Control lock                                     | -                          |
| RACK FLEXIBILITY                                 |                            |
| Vinyl rack coating                               | -                          |
| Silverware basket                                | In-the-Rack                |
| DIMENSIONS AND COLORS                            |                            |
| Height (A)                                       | 37"                        |
| Width (B)  | 24 1/4"                    |
| Depth (C)  | 26 1/2"                    |
| Available colors                                 | W   B                      |

# Dishwasher Custom Panels

## SPECIFICATIONS AND DIMENSIONS

| DIMENSIONS    | 4" FRAMELESS | 4" FRAMED |
|---------------|--------------|-----------|
| Height (A)    | 25 23/64"    | 26"       |
| Width (B)     | 23 3/4"      | 23 1/4"   |
| Thickness (C) | 3/4"         | 1/4"      |

### Installation Notes

1. Custom panel for door cannot exceed 8-lb weight
2. Upper and lower panels are not the same width
3. Match woodgrain direction with that of adjacent cabinets
4. Sand panel edges to provide a smooth finish
5. Use moisture-resistant sealer on sides and edges of panels to protect from humidity (Dishwasher is subject to humidity)

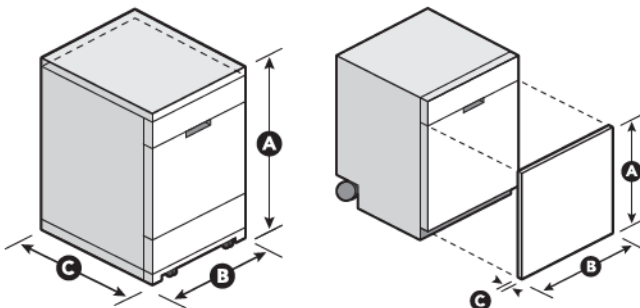

\*Per IEC standards.



# Food Disposers

## SPECIFICATIONS AND DIMENSIONS

| MODEL  | GC1000XE/PE* | GC2000XE/PE* | GC5000XE |
|--|--------------|--------------|----------|
| Motor  | 1/3-HP       | 1/2-HP       | 3/4-HP   |
| Locked-in mounting                               | -            | -            | -        |
| Continuous-feed operation                        | -            | -            | -        |
| Stainless steel grinding wheel                   | -            | -            | ♦        |
| Overload protector                               | -            | -            | -        |
| Manual reset                                     | -            | -            | -        |
| Sound insulation                                 | -            | -            | ♦        |
| Designed, engineered and assembled in the U.S.A. | -            | -            | -        |
| <b>DIMENSIONS</b>                                |              |              |          |
| A  | 11 3/4"      | 11 3/4"      | 12 3/4"  |
| B  | 5 7/8"       | 5 7/8"       | 6 3/8"   |
| C  | 4"           | 4"           | 4"       |
| D  | 6 7/8"       | 6 7/8"       | 7 1/4"   |
| E  | 5"           | 5"           | 5 1/4"   |

Bold type indicates a step-up feature

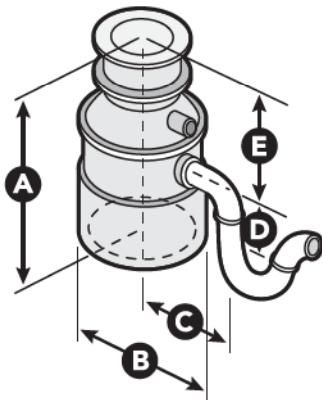

\*Also available with plug and cord.

DIMENSIONS ARE SHOWN FOR PLANNING PURPOSES ONLY.  
For complete information, see Installation Instructions packed with product.

# Trash Compactors

## SPECIFICATIONS AND DIMENSIONS

| MODEL  | WHIRLPOOL GOLD* |          | WHIRLPOOL* |
|--|-----------------|----------|------------|
|  | GX900QPP        | GC900GPP | TU950GPX   |
| Capacity (cu. ft.)                               | 1.4             | 1.4      | 1.4        |
| Convertible freestanding-to-built-in             |                 | ♦        |            |
| Under counter                                    | -               |          | ♦          |
| Touch pad controls                               | -               | -        |            |
| Fully integrated controls                        |                 |          | ♦          |
| Knob On/Off/Start                                |                 |          |            |
| Wrap around drawer panel                         | -               | -        | -          |
| Automatic anti-jam                               | -               | -        | -          |
| Clean Touch™ console                             | -               | -        | -          |
| Touch-Toe™ drawer opener                         | -               | -        | -          |
| "Hidden" removable key control knob              | -               | -        | -          |
| Easy Rollers™ installation wheels                | -               | -        | -          |
| 1/3-HP motor                                     | -               | -        | -          |
| 4-to-1 Compaction ratio                          | -               | -        | -          |
| Front levelers/rear rollers                      | -               | -        | -          |
| Bag retainer buttons                             | -               | -        | -          |
| Side release bin                                 | -               | -        | -          |
| Tilt-Away trash basket                           | -               | -        | -          |
| Tilt switch                                      | -               | -        | -          |
| Designed, engineered and assembled in the U.S.A. | -               | -        | -          |
| <b>DIMENSIONS AND COLORS</b>                     |                 |          |            |
| Height (A)                                       | 34 1/8"         | 34 1/8"  | 33 7/8"    |
| Width (B)  | 15"             | 15"      | 15"        |
| Depth (C)  | 24"             | 24"      | 24"        |
| Minimum cutout height (D)                        | 34 1/4"         | 34 1/4"  | 34 1/4"    |
| Cutout width (E)                                 | 15 1/8"         | 15 1/8"  | 15 1/8"    |
| Cutout depth (F)                                 | 24 3/4"         | 24 3/4"  | 24 3/4"    |
| Height to outlet (G)                             | 18"             | 18"      | 18"        |
| Available colors                                 | Q   B   S       | Q   B    | S          |

Bold type indicates a step-up feature

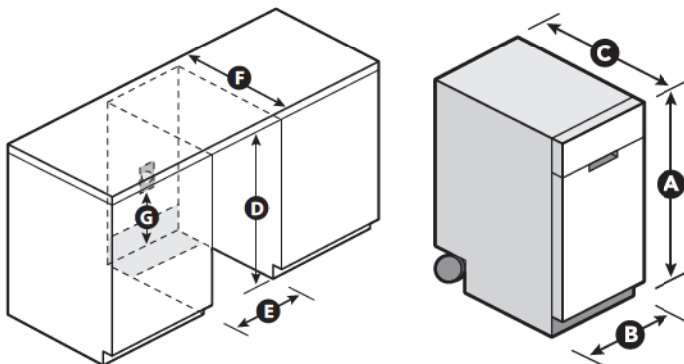

Whirlpool brand is constantly improving and innovating our products, so the specifications and dimensions in this catalog are subject to change without notice.

DIMENSIONS ARE SHOWN FOR PLANNING PURPOSES ONLY.  
For complete information, see Installation Instructions packed with product.





## LAUNDRY

- 184 High efficiency (HE) front load laundry
- 192 High efficiency (HE) top load laundry
- 200 Traditional top load laundry
- 207 Laundry 1-2-3™ custom laundry options
- 208 Specialty laundry pairs
- 210 Accessories
- 212 Glossary
- 214 Specifications





## HIGH EFFICIENCY FRONT LOAD LAUNDRY



### Colors stay vibrant

Adaptive Wash technology automatically senses and adapts to the size of each load and uses just the right amount of water to deliver great cleaning. It delivers better cleaning performance\* and gentleness by combining Precision Dispense, 14 adaptive wash actions and the Care Control temperature management system.



### Adds the detergent for you

Precision Dispense Ultra senses and adapts to each load, adding detergent, bleach and fabric softener at just the right time during the cycle. The removable detergent reservoir can hold enough detergent for up to 12 loads of laundry in a single filling.\*\*



### Washes and dries small loads right in the washer†

When the FanFresh® option with Dynamic Venting Technology® is activated, select models automatically tumble clothes for up to 12 hours until you're ready to toss them in the dryer.

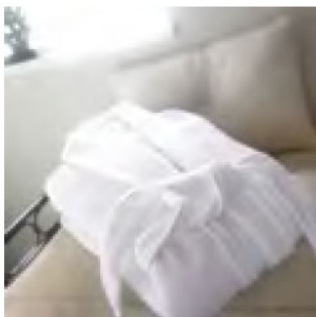

### Automatically stops when items are perfectly dry

Stop shrinking and save time and energy with Advanced Moisture Sensing. Three active built-in sensors read incoming and outgoing air temperatures and monitor moisture levels inside the dryer, while adapting the drying level to prevent overdrying.

NOTE: Not all features are available on all models.

\*Compared to traditional top load washers. \*\*Based on 2X concentration of HE detergent. †Based on a 2-lb load of lightweight fabrics.

## Duet® HE Front Load Washers

RATED A  
BEST  
BUY\*



### WFW70HEB 4.1 cu. ft. W

Recommended dryers: WE/GD70HEB, WED71HEB  
Precision Dispense  
ENERGY STAR® qualified  
Meets CEE Tier 3\*\* standards  
Tap Touch controls  
Adaptive Wash technology  
Quiet Spin 360 technology



RATED A  
RECOMMENDED BUY\*



### WFW80HEB 4.1 cu. ft. W

Recommended dryer: WE/GD80HEB  
**TumbleFresh™ option**  
**Eco Sanitize option with Oxi**  
**Eco Monitor**  
Precision Dispense  
ENERGY STAR® qualified  
Meets CEE Tier 3\*\* standards  
Tap Touch controls  
Adaptive Wash technology  
Quiet Spin 360 technology



\*According to a leading consumer magazine. \*\*Based on the Consortium for Energy Efficiency qualifying product lists. Visit [cee1.org](http://cee1.org) for more information.

Step-up features  
highlighted by  
yellow bar



Most Whirlpool® washers  
are ENERGY STAR® qualified.

## Duet® HE Dryers



**WE/GD70HEB 7.4 cu. ft. W**  
**WED71HEB 7.4 cu. ft. W**

Recommended washer: WFW70HEB  
Tap Touch controls  
Advanced Moisture Sensing  
140-minute Wrinkle Shield™ Plus option  
Quiet Dry Ultra system  
Long vent†



RATED A  
RECOMMENDED BUY\*



**WE/GD80HEB 7.4 cu. ft. W**

Recommended washer: WFW80HEB  
**Eco Monitor**  
Tap Touch controls  
Advanced Moisture Sensing  
140-minute Wrinkle Shield™ Plus option  
Quiet Dry Ultra system



\*According to a leading consumer magazine. †Model WED71HEB only.

Feature descriptions can be found in the glossary on pages 212–213. Complete product specifications can be found on pages 214–215.

## Duet® HE Front Load Washers

RATED A  
RECOMMENDED BUY\*



### WFW86HEB 4.1 cu. ft. W | C

Recommended dryer: WE/GD86HEB

#### Sanitize cycle with Steam and Heater

- Precision Dispense
- TumbleFresh™ option
- ENERGY STAR® qualified
- Meets CEE Tier 3\*\* standards
- Eco Monitor
- Tap Touch controls
- Adaptive Wash technology
- Quiet Spin 360 technology

RATED A  
RECOMMENDED BUY\*



### WFW88HEA 4.3 cu. ft. W | C

Recommended dryer: WE/GD88HEA

#### EcoBoost™ option with Eco Monitor

- Steam-enhanced cycles
- Precision Dispense
- TumbleFresh™ option
- ENERGY STAR® qualified
- Meets CEE Tier 3\*\* standards
- Sanitize cycle with Steam and Heater
- Tap Touch controls
- Adaptive Wash technology
- Quiet Spin 360 technology

\*According to a leading consumer magazine. \*\*Based on the Consortium for Energy Efficiency qualifying product lists. Visit [cee1.org](http://cee1.org) for more information.

Step-up features  
highlighted by  
yellow bar



Most Whirlpool® washers  
are ENERGY STAR® qualified.

## Duet® HE Dryers



### **WE/GD86HEB 7.4 cu. ft. W | C**

Recommended washer: WFW86HEB

Steam Refresh cycle

140-minute Wrinkle Shield™ Plus option with Steam

Tap Touch controls

Advanced Moisture Sensing

Eco Monitor

Quiet Dry Ultra system



**RATED A  
RECOMMENDED BUY\***



### **WE/GD88HEA 7.4 cu. ft. W | C**

Recommended washer: WFW88HEA

EcoBoost™ option with Eco Monitor

Steam-enhanced cycles

Tap Touch controls

Advanced Moisture Sensing

140-minute Wrinkle Shield™ Plus option with Steam

Quiet Dry Ultra system



\*According to a leading consumer magazine.

Feature descriptions can be found in the glossary on pages 212–213. Complete product specifications can be found on pages 214–215.



## Duet® HE Front Load Washers



### WF94HEA 4.3 cu. ft. W | C

Recommended dryer: WE/GD94HEA

#### 12-hour FanFresh® option with Dynamic Venting Technology®

Precision Dispense

ENERGY STAR® qualified

Meets CEE Tier 3\* standards

EcoBoost™ option with Eco Monitor

Steam-enhanced cycles

Sanitize cycle with Steam and Heater

Tap Touch controls

Adaptive Wash technology

Quiet Spin 360 technology

RATED A  
RECOMMENDED BUY\*\*



### WF96HEA 4.3 cu. ft. W | C | U

Recommended dryer: WE/GD96HEA

#### Precision Dispense Ultra

#### Active Spray technology

#### 12-hour FanFresh® option with Dynamic Venting Technology®

ENERGY STAR® qualified

Meets CEE Tier 3\* standards

EcoBoost™ option

Steam-enhanced cycles

Sanitize cycle with Steam and Heater

Tap Touch controls

Adaptive Wash technology

Quiet Spin 360 technology

\*Based on the Consortium for Energy Efficiency qualifying product lists. Visit [cee1.org](http://cee1.org) for more information. \*\*According to a leading consumer magazine.

Step-up features  
highlighted by  
yellow bar



Most Whirlpool® washers  
are ENERGY STAR® qualified.

## Duet® HE Dryers

RATED A  
RECOMMENDED BUY\*\*



### WE/GD94HEA 7.4 cu. ft. W | C

Recommended washer: WFW94HEA

#### Static Reduce option

Tap Touch controls

Advanced Moisture Sensing

EcoBoost™ option with Eco Monitor

Steam-enhanced cycles

140-minute Wrinkle Shield™ Plus option with Steam

Quiet Dry Ultra system



RATED A  
RECOMMENDED BUY\*\*



### WE/GD96HEA 7.4 cu. ft. W | C | U

Recommended washer: WFW96HEA

#### SilentSteel™ dryer drum

Tap Touch controls

Advanced Moisture Sensing

EcoBoost™ option with Eco Monitor

Steam-enhanced cycles

140-minute Wrinkle Shield™ Plus option with Steam

Static Reduce option

Quiet Dry Ultra system



\*\*According to a leading consumer magazine.

Feature descriptions can be found in the glossary on pages 212–213. Complete product specifications can be found on pages 214–215.



## HIGH EFFICIENCY TOP LOAD LAUNDRY



### Colors stay vibrant

Adaptive Wash technology automatically senses and adapts to the size of each load and uses just the right amount of water to deliver great cleaning. It delivers better cleaning performance\* and gentleness by combining Precision Dispense, 11 adaptive wash actions and the Care Control temperature management system.



### Saves over \$3,300 in lifetime energy costs\*\*

Save time, money and energy with an ENERGY STAR® qualified washer and high-efficiency dryer. These laundry pairs more than pay for themselves\*\* while using less water and electricity.

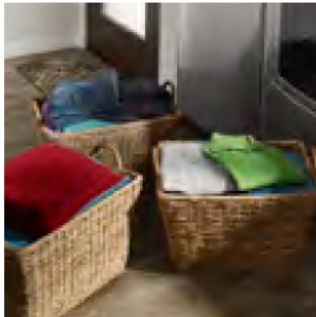

### Wash more than three baskets of laundry in one load

Take care of all your laundry needs with a washer and dryer that's designed to handle large loads. Wash multiple baskets of laundry inside the 4.8 cu. ft. washer. Then transfer your laundry to the 7.6 cu. ft. dryer that easily adapts to both small and large loads for optimal fabric care.

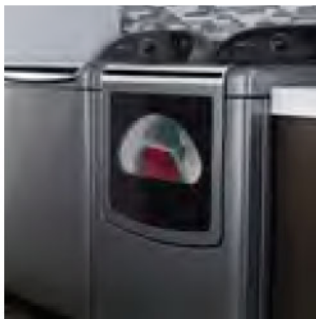

### Stops drying when items are ready

Whirlpool brand brings high efficiency to the dryer with Advanced Moisture Sensing and the AccuDry™ sensor drying system. Stop shrinking and save time and energy with HE Cabrio® dryers that monitor moisture levels and end the cycle when everything is dry.

NOTE: Not all features are available on all models.

\*Compared to traditional top load washers. \*\*Compared to pre-2004 traditional top load washers and dryers, based on average use, using normal cycle, 11-year average washer life and 12-year average dryer life, electric models only.



## Cabrio® HE Top Load Washers



### **WTW5500B 3.8 cu. ft. W**

Recommended dryer: WE/GD5500B  
Adaptive Wash technology  
Precision Dispense  
Cold Wash cycle  
Smooth impeller  
Smooth Spiral stainless steel wash basket  
ENERGY STAR® qualified  
Meets CEE Tier 3\* standards  
Wide open lid  
Deep Water Wash cycle



### **WTW5800B 3.8 cu. ft. W | C**

Recommended dryer: WE/GD5800B  
**EcoBoost™ option with Eco Monitor**  
**Presoak option**  
**EasyView™ framed glass lid**  
**Estimated time remaining LED display**  
**Deep Clean option**  
**Delay Wash option**  
Adaptive Wash technology  
Precision Dispense  
Cold Wash cycle  
Smooth impeller  
Smooth Spiral stainless steel wash basket  
ENERGY STAR® qualified  
Meets CEE Tier 3\* standards  
Deep Water Wash cycle

\*Based on the Consortium for Energy Efficiency qualifying product lists. Visit [cee1.org](http://cee1.org) for more information.

Step-up features  
highlighted by  
yellow bar



Most Whirlpool® washers  
are ENERGY STAR® qualified.



## Cabrio® HE Dryers



### **WE/GD5500B 7.4 cu. ft. W**

Recommended washer: WTW5500B  
AccuDry™ sensor drying system  
90-minute Wrinkle Shield™ option  
Quiet Dry noise reduction system  
Drum light  
Hamper door



### **WE/GD5800B 7.4 cu. ft. W | C**

Recommended washer: WTW5800B  
EcoBoost™ option with Eco Monitor  
150-minute Wrinkle Shield™ option  
Sanitize cycle  
Eco Normal cycle  
Estimated time remaining LED display  
On/Off drum light  
Hamper door with window  
Damp Dry signal  
AccuDry™ sensor drying system  
Quiet Dry noise reduction system

---

Feature descriptions can be found in the glossary on pages 212–213. Complete product specifications can be found on pages 216–217.

## Cabrio® Platinum HE Top Load Washers



### **WTW800B 4.5 cu. ft. W**

Recommended dryer: WE/GD8000B

**Precision Dispense Plus**

**Direct drive motor**

**Quiet Wash Ultra noise reduction system**

Adaptive Wash technology

EcoBoost™ option with Eco Monitor

Smooth impeller

Smooth Spiral stainless steel wash basket

ENERGY STAR® qualified

Meets CEE Tier 3\* standards

Delay Wash option

Estimated time remaining LED display



### **WTW8100B 4.5 cu. ft. W**

Recommended dryer: WE/GD8100B

**EasyView™ framed glass lid**

Adaptive Wash technology

Precision Dispense Plus

EcoBoost™ option with Eco Monitor

Smooth impeller

Smooth Spiral stainless steel wash basket

Direct drive motor

ENERGY STAR® qualified

Meets CEE Tier 3\* standards

Quiet Wash Ultra noise reduction system

Delay Wash option

Estimated time remaining LED display

\*Based on the Consortium for Energy Efficiency qualifying product lists. Visit [cee1.org](http://cee1.org) for more information.

Step-up features  
highlighted by  
yellow bar



Most Whirlpool® washers  
are ENERGY STAR® qualified.

## Cabrio® Platinum HE Dryers



### **WE/GD8000B 7.6 cu. ft. W**

Recommended washer: WTW8000B

- Advanced Moisture Sensing
- Quiet Dry Ultra noise reduction system
- On/Off Damp Dry signal
- Reversible side-swing door
- EcoBoost™ option with Eco Monitor
- 150-minute Wrinkle Shield™ option
- Sanitize cycle
- Estimated time remaining LED display
- Drum light



### **WE/GD8100B 7.6 cu. ft. W**

Recommended washer: WTW8100B

- Reversible side-swing door with window
- Advanced Moisture Sensing
- EcoBoost™ option with Eco Monitor
- 150-minute Wrinkle Shield™ option
- Sanitize cycle
- Quiet Dry Ultra noise reduction system
- Estimated time remaining LED display
- Drum light
- On/Off Damp Dry signal

Feature descriptions can be found in the glossary on pages 212–213. Complete product specifications can be found on pages 218–219.

## Cabrio® Platinum HE Top Load Washers



### **WTW8500B 4.8 cu. ft. W | C**

Recommended dryer: WE/GD8500B

**Cold Wash cycle**

**Unique soft-touch impeller**

**Soak cycle**

**Active Wear cycle**

Adaptive Wash technology

Precision Dispense Plus

EcoBoost™ option with Eco Monitor

Smooth Spiral stainless steel wash basket

Direct drive motor

ENERGY STAR® qualified

Meets CEE Tier 3\* standards

Quiet Wash Ultra noise reduction system

EasyView™ framed glass lid

Delay Wash option

Estimated time remaining LED display



### **WTW8900B 4.8 cu. ft. W | C**

Recommended dryer: WE/GD8900B

**Deep Clean option with Heater**

**Sanitary cycle with Steam and Oxi**

**EasyView™ frameless glass lid with slow-close hinge**

**Deep Water Soak cycle**

**Chrome accents**

Adaptive Wash technology

Precision Dispense Plus

Cold Wash cycle

EcoBoost™ option with Eco Monitor

Unique soft-touch impeller

Smooth Spiral stainless steel wash basket

Direct drive motor

ENERGY STAR® qualified

Meets CEE Tier 3\* standards

Quiet Wash Ultra noise reduction system

Active Wear cycle

Delay Wash option

Estimated time remaining LED display

\*Based on the Consortium for Energy Efficiency qualifying product lists. Visit [cee1.org](http://cee1.org) for more information.

Step-up features  
highlighted by  
yellow bar



Most Whirlpool® washers  
are ENERGY STAR® qualified.

## Cabrio® Platinum HE Dryers



### **WE/GD8500B 7.6 cu. ft. W | C**

Recommended washer: WTW8500B

**Enhanced Touch Up Steam cycle**

**Active Wear cycle**

Advanced Moisture Sensing

EcoBoost™ option with Eco Monitor

150-minute Wrinkle Shield™ option

Sanitize cycle

Quiet Dry Ultra noise reduction system

Estimated time remaining LED display

Drum light

On/Off Damp Dry signal

Reversible side-swing door with window



### **WE/GD8900B 7.6 cu. ft. W | C**

Recommended washer: WTW8900B

**Quick Refresh Steam cycle**

**150-minute Wrinkle Shield™ Plus option with Steam**

**Static Reduce option**

**Chrome accents**

Advanced Moisture Sensing

EcoBoost™ option with Eco Monitor

Enhanced Touch Up Steam cycle

Sanitize cycle

Quiet Dry Ultra noise reduction system

Estimated time remaining LED display

Drum light

On/Off Damp Dry signal

Active Wear cycle

Reversible side-swing door with window

Feature descriptions can be found in the glossary on pages 212–213. Complete product specifications can be found on pages 218–219.





## TRADITIONAL TOP LOAD LAUNDRY



### **Saves water and energy**

Whirlpool® traditional laundry pairs not only feature a new and improved design, but they also include ENERGY STAR® qualified washers. Select models with Adaptive Wash technology even meet the CEE Tier 3\* standard.



### **Tracks progress**

All Whirlpool brand traditional washers let you clearly see which part of the cycle your washer is running, including Sensing, Wash, Rinse, Spin, Done and Lid Lock.



### **Gently lifts stains**

The Deep Water Wash cycle helps break down loose soils, while the Cold Wash cycle gently lifts stains and soils from fabrics. It uses adaptive wash actions, a concentrated solution of HE detergent and cold water to deliver great cleaning and protect fabrics.



### **Uses less energy**

The AccuDry™ sensor drying system uses less energy than dryers equipped with the AutoDry™ system,\*\* helping to lower your monthly electric bills. The sensor drying system reduces overdrying by monitoring moisture levels and temperatures.

NOTE: Not all features are available on all models.

\*Based on the Consortium for Energy Efficiency qualifying product lists. Visit [cee1.org](http://cee1.org) for more information. \*\*Electric models only.

## Traditional Top Load Washers



### **WTW4800B 3.6 cu. ft. Q**

- Recommended dryer: WE/GD4800B
- Smooth motion agitator
- Wide open lid
- Cycle status bar
- Quiet Spin technology
- Extra Rinse option with Fabric Softener
- Extra-large Load Size option



### **WTW4850B 3.6 cu. ft. W**

- Recommended dryers: WE/GD4850B, WE/GD4890B
- Cold Wash cycle
- Deep Water Wash cycle
- ENERGY STAR® qualified
- Presoak option
- Soak cycle
- Quick Wash cycle
- Smooth motion agitator
- Wide open lid
- Cycle status bar
- Quiet Spin technology
- Extra Rinse option with Fabric Softener

Step-up features highlighted by yellow bar



Most Whirlpool® washers are ENERGY STAR® qualified.

## Traditional Dryers



**WE/GD4800B 7.0 cu. ft. Q**

Recommended washer: WTW4800B  
AutoDry™ drying system  
40-minute Wrinkle Shield™ option  
Reversible side-swing door



**WE/GD4850B 7.0 cu. ft. HIGH EFFICIENCY W**

Recommended washers: WTW4850B, WTW4900B  
AccuDry™ sensor drying system  
90-minute Wrinkle Shield™ option  
Wide-opening hamper door  
Drum light

---

Feature descriptions can be found in the glossary on pages 212–213. Complete product specifications can be found on pages 220–221.

## Traditional Top Load Washers



### **WTW4900B 3.8 cu. ft. HIGH EFFICIENCY W**

Recommended dryers: WE/GD4850B, WE/GD4890B

Smooth impeller

Smooth Spiral stainless steel wash basket

Meets CEE Tier 3\* standards

Cold Wash cycle

Deep Water Wash cycle

ENERGY STAR® qualified

Presoak option

Soak cycle

Wide open lid

Quick Wash cycle

Cycle status bar

Quiet Spin technology

Extra Rinse option with Fabric Softener

\*Based on the Consortium for Energy Efficiency qualifying product lists. Visit [cee1.org](http://cee1.org) for more information.

Step-up features  
highlighted by  
yellow bar



Most Whirlpool® washers  
are ENERGY STAR® qualified.



## Traditional Dryers



### **WE/GD4890B 6.4 cu. ft. HIGH EFFICIENCY W**

Recommended washers: WTW4850B, WTW4900B

- Smooth, flat back design
- AccuDry™ sensor drying system
- 90-minute Wrinkle Shield™ option
- Reversible side-swing door
- Drum light

---

Feature descriptions can be found in the glossary on pages 212–213. Complete product specifications can be found on pages 220–221.

# Duet® Laundry Pair Installation

## INNOVATIONS THAT FIT YOUR LIFE AND HOME



**The best-selling laundry appliance brand in the U.S.A.\*** offers washers and dryers that are carefully crafted to fit seamlessly into your life and home.

Innovative features help get you out of the laundry room and back to doing what you love to do. Our 27" design fits through doors and hallways so you don't have to dismantle the home you're trying to complete.

Models: Duet® washer WFW96HEAU and Duet® dryer WE/GD96HEAU with optional 15.5" pedestals XHPC155YU

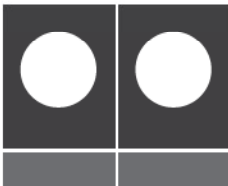

Use 10" pedestals to place doors at the best height for customers shorter than 5'4" tall.

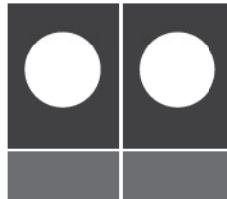

Add 15.5" pedestals to place doors at the best height for customers 5'4" or taller.

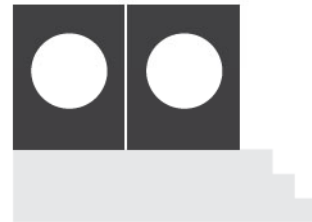

Superb vibration control systems mean upstairs installation is always possible.

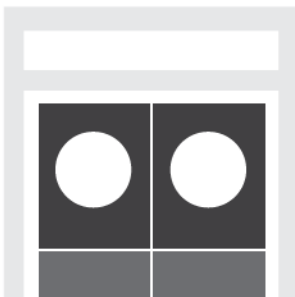

Installation in a standard closet places the laundry area close to living spaces. Even in a closet, full-sized pairs may be stacked or placed side-by-side with or without pedestals.



When stacked,\*\* the dryer controls are still at a comfortable height. Plus, a direct water hookup for the steam dryer means no reservoir to fill.

\*Trajectory, 2013. \*\*Requires stack kit, see page 210 for accessory information.

## Laundry 1-2-3™ Pedestals



Using height as a guide, choose the recommended pedestal while also taking into consideration the height of any cabinets above your laundry pair.

| Height      | Recommended Pedestal | Approx. Height with Pedestal |
|-------------|----------------------|------------------------------|
| 5'4" and up | 15.5"                | 53.5"                        |
| Under 5'4"  | 10"                  | 48"                          |

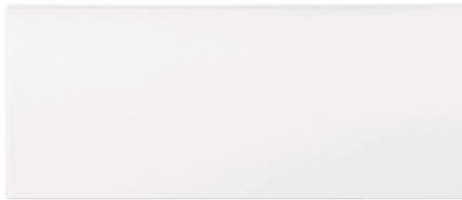

### LAB0050P Q

12" Height

Recommended for compact laundry pairs

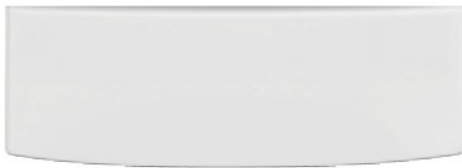

### XHP1000X W

10" Height

Recommended for all Duet® front load laundry pairs



### XHPC155X W XHPC155Y C | U

Chrome handle

Storage drawer

15.5" Height

Recommended for all Duet® front load laundry pairs



Feature descriptions can be found in the glossary on pages 212–213. Complete product specifications can be found on page 225.

## Thin Twin® Laundry Centers



### **LTE/G5243D 4.9 total cu. ft. Q**

#### **DRYER**

3.4 cu. ft. dryer capacity  
18 cycles / 4 temperatures

#### **WASHER**

1.5 cu. ft. washer capacity  
Surgilator® agitator  
Tough Top™ II top and lid  
5 cycles / 4 temperatures



### **WE/GT3300X 8.4 total cu. ft. Q**

#### **DRYER**

5.9 cu. ft. dryer capacity  
6 cycles / 3 temperatures

#### **WASHER**

2.5 cu. ft. washer capacity  
Two-piece Surgilator® agitator  
8 cycles / 4 temperatures

Step-up features  
highlighted by  
yellow bar



Most Whirlpool® washers  
are ENERGY STAR® qualified.

## Compact Laundry Pairs



### **WED7500V 3.8 cu. ft. W**

#### DRYER

- AutoDry™ drying system
- Stainless steel dryer drum
- Moisture sensor control
- Dryer stack kit included
- 11 cycles / 2 temperatures

### **WFC7500V 2.0 cu. ft. W**

#### WASHER

- ENERGY STAR® qualified
- Meets CEE Tier 1\* standards
- Stainless steel wash basket
- Cycle status bar
- Estimated time remaining display
- 8 cycles / 3 temperatures



Shown with optional stack stand (49971)

### **LER3622P 3.4 cu. ft. Q**

#### DRYER

- 3 cycles / 2 temperatures

### **LDR3822P 3.4 cu. ft. Q**

#### DRYER

- AccuDry™ sensor drying system
- 3 cycles / 2 temperatures

### **LCE4332P 2.1 cu. ft. Q**

#### WASHER

- Straight vane agitator
- 4 cycles / 3 temperatures

\*Based on the Consortium for Energy Efficiency qualifying product lists. Visit [cee1.org](http://cee1.org) for more information.

Feature descriptions can be found in the glossary on pages 212–213. Complete product specifications can be found on pages 222–224.



## Accessories



### affresh® Washer Cleaner (W10135699)

Effectively remove odor-causing residue in all washers. Keeps your machine fresher and cleaner when used monthly. Contains 3 pucks.



### Front Load Stack Kits (W10298318RP)

Install a 7.5 cu. ft. front load dryer on top of its matching washer with this stack kit. Retail polybag over pack of 12.



### Precision Dispense HE Detergent Dispenser (W10250743A)

Adds the right amount of detergent at the right time during the cycle. Extra dispenser provides flexibility in changing detergent.



### Compact Model Stack Stand (49971)

Install compact dryer model LER3622P or LDR3822P on top of the LCE4332P compact washer model with this stack stand.



### Washable Delicates Bag (W10180464RP)

Protect delicate items from snags, tangles and tears while machine washing and drying. 15-1/2" (L) x 16-1/2" (W).



### Dryer Lint Brush (8212614)

Extend dryer life, lower utility bills and reduce drying time by regularly and thoroughly removing lint with this cleaning brush. For lint screen on top. Size 40" (L) x 2" (W) x 2" (D).



### Laundry 1-2-3™ Adjustable Clothes Rack (XHS1000XX)

Hang garments straight from the washer or dryer with this clothes rack. It's also collapsible for quick, easy storage.



### Top Load Washer/Dryer Cover (W10214580RP)

Protect your top load washer or dryer from environmental damage with this gray cover. The cover also cleans easily with a damp cloth.



### Industrial-Grade Washer Hoses 8212638RP: (2) 6' Nylon Braided w/90° elbow

8212487RP: (2) 5' Nylon Braided  
8212545RP: (2) 5' Red & Blue EPDM  
8212656RP: (2) 10' Black EPDM  
8212546RP: (2) 4' Black EPDM  
8212641RP: (2) 5' Black EPDM

Industrial strength hoses safely and efficiently transport hot and cold water to the washer.



### Dryer Racks

Models 70HEB, 71HEB, 80HEB, 86HEB, 88HEA, 94HEA, 96HEA: W10322470A

Models 8000B, 8100B, 8500B and 8900B: 8577312A

Models 5500B and 5800B: 8212450A  
Models 4800B and 4850B: 3406839

The dryer rack is convenient for flat items such as sweaters and hats, or for bulky items like footwear and stuffed animals. A quick and easy insertion of this lightweight rack means tumble-free drying.



### Steam Dryer Hose kit Models 86HEB, 88HEA, 94HEA, 96HEA: W10473735

This dryer hose kit is especially made for steam dryers and includes (1) 5' hook-up hose, (1) 2' hook-up hose and O-rings.

To acquire pricing information, order Whirlpool® laundry accessories and determine delivery time, visit [whirlpool.com/accessories](http://whirlpool.com/accessories) or call 1-800-462-3819.

# Accessories

## Optional Accessories



| DRYER CORDS             |            |
|-------------------------|------------|
| 4', 3-wire, 30 amp      | PT220L     |
| 4', 4-wire, 30 amp      | PT400L     |
| 6', 4-wire, 30 amp      | PT600L     |
| Gas dryer connector kit | 20-48KITRC |

| LP GAS CONVERSION KITS                                     |                        |
|--|------------------------|
| 24" Thin Twin® laundry and compacts                        | 49573 (10,500 BTU)     |
| 27" Thin Twin® laundry centers                             | 3392235 (16,000 BTU)   |
| Full-size gas dryers (lint screen on top)                  | 49572A (22,000 BTU)    |
| Duet® dryers (70HEB, 80HEB, 86HEB, 88HEA, 94HEA and 96HEA) | W10307153 (20,000 BTU) |
| Duet® dryers (lint screen front)*                          | W10317689 (20,000 BTU) |

| WASHER ACCESSORIES  |           |
|---|-----------|
| (2) 5' Reinforced braid fill hoses (all washers)                                      | 8212487RP |
| 2' Siphon break kit (27" & 29" washers)   | 285834    |
| Drain reducer kit (29" washers)   | 40923     |
| 4' Drain extension kit (includes coupler, 2 clamps and 4' drain hose with fitted end) | DRNEXT4   |

## Exhaust Information

All dryers require the equivalent of a 4-inch diameter exhaust duct. Whirlpool Corporation recommends using a rigid metal duct to minimize the risk of lint fires and melted venting.

| 27" & 29" DRYER VENTING REQUIREMENTS | 4" HOOD (4396007RW)   | 4" HOOD (8212662)   |
|--------------------------------------|---|---|
|                                      |  |  |
| Number of 90° turns                  | 4"  | 4"  |
| 0                                    | 64' / 36***   | 64' / 36***   |
| 1                                    | 54' / 31***   | 54' / 31***   |
| 2                                    | 44' / 27***   | 44' / 27***   |
| 3                                    | 35' / 25***   | 35' / 25***   |
| 4                                    | 27' / 23***   | 27' / 23***   |

## 24" Compact long vent drying requirements (WED7500V)

| NUMBER OF 90° TURNS OR ELBOWS | TYPE OF VENT                 | BOX OR LOUVERED HOODS       | ANGLED HOODS                |
|-------------------------------|------------------------------|-----------------------------|-----------------------------|
| 0                             | Rigid metal / Flexible metal | 90' (27.4 m) / 64' (19.5 m) | 80' (24.4 m) / 58' (17.7 m) |
| 1                             | Rigid metal / Flexible metal | 80' (24.4 m) / 58' (17.7 m) | 70' (21.3 m) / 52' (15.8 m) |
| 2                             | Rigid metal / Flexible metal | 70' (21.3 m) / 50' (15.2 m) | 60' (18.3 m) / 42' (12.8 m) |

## 8' DuraSafe™ Dryer Vent Installer's Kit (4396013RB)

Kit Contains:

- (1) 4' pipe section attached to (1) close elbow
- (1) 4' pipe section attached to (1) wall-offset elbow
- (1) Extension collar
- (2) Clamps for wall and dryer connection
- Installation instructions

\*Refer to Use & Care Guide for specific model. \*\*Maximum length of 4" diameter rigid metal duct and flexible metal duct.

# Glossary

## AccuDry™ sensor drying system

Measures moisture and temperature levels to reduce overdrying and automatically stop the cycle when the load is dry. Dryers with the AccuDry™ system use less energy than Whirlpool® top load dryers equipped with the AutoDry™ system.\*

## Active Spray technology

Sprays the load with detergent in a cone-shaped pattern to completely and evenly cover the fabrics.

## Adaptive wash actions

Up to 14 different adaptive wash actions in front load laundry and up to 11 in top load laundry, from rocking to tumbling, adapt to the cleaning needs of each load. These adaptive wash actions provide a combination of powerful cleaning and gentle fabric care, handling everything from heavily soiled jeans to delicate silks.

## Adaptive Wash technology

Colors stay vibrant as Adaptive Wash technology delivers better cleaning performance\*\* and gentleness. It combines Precision Dispense, adaptive wash actions and the Care Control temperature management system to help clothes look their best.

## Advanced Moisture Sensing

Stop shrinking with Whirlpool brand's most advanced drying system. It uses precise drying and three built-in sensors, including an inlet thermistor and moisture sensing strips, to read temperature and moisture levels, so the drying cycle can end when everything is thoroughly dry, saving time and energy.

## Allergen cycle

Remove up to 95% of common allergens from your clothes with the Allergen cycle.†

## AutoDry™ drying system

Automatically senses when clothes have reached the right temperature and stops the cycle to save energy.

## Care Control temperature management system

Adjusts the cold and hot water inlets to reach temperatures that are warm enough to dissolve detergents. Water is kept from overheating to help reduce shrinking and color bleeding.

## CEE Tier standards

Based on the Consortium for Energy Efficiency (CEE) qualifying product lists—with Tier 3 being the most efficient. These models feature advanced water and energy savings and may qualify for rebates from local utility companies. Visit [ceef.org](http://ceef.org) for more information.

## Clean Washer cycle with affresh® Washer cleaner

Deep-fills the washer to clean areas that low-water systems don't typically reach. All it takes is one cup of bleach. Using affresh® Washer cleaner also effectively eliminates odor-causing residue and cleans mold and mildew stains.

## Cold Wash cycle

Uses adaptive wash actions together with a concentrated solution of HE detergent and cold water to gently lift stains and soils from fabrics. This cycle delivers great cleaning while protecting fabrics from heat damage and using less energy.

## Deep Clean option

Penetrates deep into fabric fibers, breaking down and dissolving stains without pretreating. Select models add steam enhancement for even better cleaning.

## Deep Water Wash option

Helps break down loose soils and using more water and thorough cleaning.

## Delay Wash option

Sets the washer to begin cleaning up to 18 hours later, during off-peak hours when utility rates may be lower or when unloading the washer is more convenient.

## Direct drive motor

Handles larger capacity loads, enhances the spin speed for improved energy savings and uses fewer moving parts so there's less wear and tear over time.

## EasyView™ glass lid

Framed models feature a see-through glass lid that allows you to look inside and see the wash action while the load is in progress. It features a frameless design for a larger viewable area and a Smooth Close lid that opens and closes easily without slamming.

## EcoBoost™ option with Eco Monitor

In the washer, this option uses a lower temperature and increased spin speed or mechanical action to provide excellent cleaning and reduce your overall energy use. In the dryer, this option saves energy by using less heat and an increased cycle time. You can even track the energy use of this eco-friendly option with the Eco Monitor.

## Eco Normal cycle

Saves up to 40% dryer energy when paired with a matching Duet® or Cabrio® washer, compared to a traditional top load laundry pair.††

## ENERGY STAR® qualified

Meets government standards to help conserve natural resources and save money on your utility bills.

## Fabric Sense™ wash system

Available in select top load washers, the Fabric Sense™ wash system automatically matches your needs to the optimal temperature, cycle time and agitation speed for customized care and cleaning.

## FanFresh® option with Dynamic Venting Technology®

After the wash cycle, the FanFresh® option's built-in washer fan circulates air in the washer, keeping your clean clothes fresh and free from odors for up to 12 hours. When activated, select models will automatically tumble clothes for up to 12 hours. You can even wash and dry a small load right in the washer.‡

\*Electric models only. \*\*Compared to traditional top load washers. †Allergens tested were dust mites and pet dander. ††Electric models only. ‡Based on a 2-lb load of lightweight fabrics.



# Glossary

## High efficiency (HE) sensor drying

Whirlpool brand brings high efficiency to the dryer with models featuring AccuDry™ sensor drying systems. Select models with Advanced Moisture Sensing also save energy and deliver better cleaning by adjusting dry time and temperature as needed and stopping the cycle when clothes are dry.

## Oxi Dispense option

Enhances whitening performance with an eco-friendly alternative to bleach. An automatic dispenser distributes the oxygenated additive at the appropriate time, sending oxygen through the load to brighten fabrics.

## Precision Dispense

Senses and adapts to each load, adding detergent, bleach or fabric softener at just the right time. A concentrated burst of detergent showers directly onto clothes to penetrate stains and pretreat soils. Precision Dispense Plus models add the ability to release oxi additives.

## Precision Dispense Ultra

Penetrates stains and pretreats soils with a concentrated burst of detergent and holds enough 2X concentration HE detergent for up to 12 loads of laundry in a single filling.

## Quad dryer baffles

Four shorter, staggered baffles increase the effectiveness of the dryer and promote better, more even tumbling.

## Quick Wash/Dry cycle

Designed to clean or dry small, lightly soiled loads in less time using increased spin speeds to extract more water. The Quick Dry cycle even allows you to finish drying a load in as little as 13 minutes.

## Quiet Spin technology

Install your top load laundry pair on a second floor and be assured of great out-of-balance performance and vibration control. Quiet Spin 360 technology's dual-ring ball-balancing system makes it our highest level of vibration control in front load laundry.

## Quiet Wash/Dry noise reduction systems

Keep operational sounds inside the washer and dryer and out of living areas with sound-absorbing materials around the wash basket and dryer drum. Escalating levels of sound reduction are available, up to Quiet Wash Ultra and Quiet Dry Ultra.

## Reduce Static/Static Reduce option

Uses tumbling and a spray mist in the dryer to evenly reduce the amount of static in an entire load of clothes.

## Sanitization cycles/options

Eliminate 99.9% of certain household bacteria.<sup>††</sup> In select dryers, this feature provides excellent care for your clothes while eliminating 99.9% of three common household bacteria without washing.<sup>§</sup>

## SilentSteel™ dryer drum

Forget about the sound of metal buttons and zippers making noise as they tumble, thanks to a unique sound-dampening material that surrounds the stainless steel dryer drum. The dryer runs quieter, even when you load items with metal accents.

## Smooth impeller

Select high-efficiency wash systems feature a specially designed low-profile plate at the bottom of the wash basket to give you more wash capacity and better fabric care.

## Smooth motion agitator

Brings your laundry to the bottom of the wash basket where cleaning takes place. It can effectively roll over and clean twice the average size load (based upon a 7-lb average load size).

## Smooth Spiral stainless steel wash basket

The stainless steel wash basket resists odors and rust and features a spiral design for greater fabric care and gentle cleaning performance.

## Stainless steel washer and dryer drum

The drum's stainless steel construction has a smooth surface that resists odors, rust and chipping and helps prevent fabrics from snagging or tearing.

## Steam technology

In the washer, steam breaks down and dissolves tough stains without pretreating. In the dryer, features like the Enhanced Touch Up Steam cycle and Quick Refresh Steam cycle combine mist with heat to create steam to relax wrinkles and refresh dry clothes. Whirlpool® steam dryers also feature a Y-connector so you don't have to add water manually before starting a steam cycle.

## Tap Touch controls

Allows direct access to washer and dryer functions, and its sleek appearance enhances the appeal of any space.

## TumbleFresh™ option

Activates after the wash cycle is finished and rolls clean clothes periodically to help prevent wrinkles from setting in. Clothes stay fresh without having to transfer them to the dryer immediately.<sup>§§</sup>

## Unique soft-touch impeller

Moves clothes gently through the water to provide excellent cleaning performance and gentle fabric care. To protect fabrics and fibers during the wash cycle, a specially designed material fully wraps the impeller vanes.

## Wrinkle Shield™/Wrinkle Shield™ Plus option with Steam

Tumbles the dryer every 5 minutes after the cycle is complete to help prevent wrinkles from setting into clean, dry fabrics. The intermittent tumbling can continue for up to 150 minutes (based on the model), or until the door is opened and the load is removed. Wrinkle Shield™ Plus option adds the power of steam to the tumbling for improved results.

<sup>††</sup>Bacteria tested were *K. pneumoniae*, *P. aureginosa* and *S. aureus*. <sup>§</sup>Bacteria tested were *K. pneumoniae*, *staphylococcus aureus* and *P. aureginosa*.  
<sup>§§</sup>Intermittent tumbling in the washer helps reduce the growth of odor-causing bacteria.

# Duet® HE Front Load Washers

## SPECIFICATIONS AND DIMENSIONS

| WASHER MODEL                                      | WHIRLPOOL®                         |                                    |                                    |                                    |                                    |  |
|---|------------------------------------|------------------------------------|------------------------------------|------------------------------------|------------------------------------|--|
|   | WFW70HEB<br>WE/GD70HEB<br>WED71HEB | WFW80HEB<br>WE/GD80HEB             | WFW86HEB<br>WE/GD86HEB             | WFW88HEA<br>WE/GD88HEA             | WFW94HEA<br>WE/GD94HEA             | WFW96HEA<br>WE/GD96HEA                         |
| RECOMMENDED DRYER                                 |                                    |                                    |                                    |                                    |                                    |  |
| New 2013 model                                    | -                                  | -                                  | -                                  | -                                  | -                                  | -  |
| Capacity (cu. ft.)                                | 4.1                                | 4.1                                | 4.1                                | <b>4.3</b>                         | 4.3                                | 4.3  |
| High-efficiency washer                            | -                                  | -                                  | -                                  | -                                  | -                                  | -  |
| ENERGY STAR® qualified                            | -                                  | -                                  | -                                  | -                                  | -                                  | -  |
| Meets CEE Tier standards*                         | Tier 3                             | Tier 3                             | Tier 3                             | Tier 3                             | Tier 3                             | Tier 3   |
| Water use/Energy use**                            | 77% less / 81% less                | 77% less / 81% less                | 77% less / 81% less                | <b>83% less / 85% less</b>         | 83% less / 85% less                | 83% less / 85% less                            |
| Tap Touch controls                                | -                                  | -                                  | -                                  | -                                  | -                                  | -  |
| Estimated time remaining display                  | LED                                | LED                                | LED                                | LED                                | LED                                | LED  |
| Eco Monitor                                       | -                                  | ♦                                  | -                                  | -                                  | -                                  | -  |
| Add-a-Garment indicator                           | -                                  | -                                  | -                                  | -                                  | -                                  | -  |
| End-of-cycle signal                               | -                                  | <b>On/Off</b>                      | On/Off                             | On/Off                             | On/Off                             | On/Off   |
| LED basket light                                  | -                                  | -                                  | -                                  | -                                  | <b>On/Off</b>                      | On/Off   |
| Stainless steel wash basket                       | -                                  | -                                  | -                                  | -                                  | -                                  | -  |
| Water heater                                      | -                                  | -                                  | ♦                                  | -                                  | -                                  | -  |
| Designed, engineered and assembled in the U.S.A.  | -                                  | -                                  | -                                  | -                                  | -                                  | -  |
| <b>WASH SYSTEM</b>                                |                                    |                                    |                                    |                                    |                                    |  |
| Active Spray technology                           | -                                  | -                                  | -                                  | -                                  | -                                  | ♦  |
| Adaptive Wash technology                          | -                                  | -                                  | -                                  | -                                  | -                                  | -  |
| Precision Dispense                                | -                                  | -                                  | -                                  | -                                  | -                                  | <b>Ultra</b>                                   |
| Adaptive wash actions                             | 14                                 | 14                                 | 14                                 | 14                                 | 14                                 | 14   |
| Automatic dispensers                              | Detergent, bleach, fabric softener | Detergent, bleach, fabric softener | Detergent, bleach, fabric softener | Detergent, bleach, fabric softener | Detergent, bleach, fabric softener | <b>Bulk detergent, bleach, fabric softener</b> |
| Care Control temperature management system        | -                                  | -                                  | -                                  | -                                  | -                                  | -  |
| Quiet Spin 360 technology                         | -                                  | -                                  | -                                  | -                                  | -                                  | -  |
| Quiet Wash Ultra system                           | -                                  | -                                  | -                                  | -                                  | -                                  | -  |
| Max spin speed (RPM)                              | up to 1,200                        | up to 1,200                        | up to 1,200                        | <b>up to 1,400</b>                 | up to 1,400                        | up to 1,400                                    |
| Total number of temperatures                      | 4                                  | 4                                  | 4                                  | 4                                  | 5                                  | 5  |
| Suds sensor                                       | -                                  | -                                  | -                                  | -                                  | -                                  | -  |
| <b>CYCLES AND OPTIONS</b>                         |                                    |                                    |                                    |                                    |                                    |  |
| Total number of cycles                            | 7                                  | 9                                  | 10                                 | 11                                 | 12                                 | 12   |
| Steam-enhanced cycles                             | -                                  | -                                  | -                                  | ♦                                  | -                                  | -  |
| Wash and Dry cycle                                | -                                  | -                                  | -                                  | -                                  | ♦                                  | -  |
| Quick Wash cycle                                  | -                                  | -                                  | -                                  | -                                  | -                                  | -  |
| Delicate cycle                                    | -                                  | -                                  | -                                  | -                                  | -                                  | -  |
| Cold Wash cycle                                   | -                                  | -                                  | -                                  | -                                  | -                                  | -  |
| Normal cycle                                      | -                                  | -                                  | -                                  | -                                  | -                                  | -  |
| Whites cycle                                      | -                                  | ♦                                  | -                                  | -                                  | -                                  | -  |
| Heavy Duty cycle                                  | -                                  | -                                  | -                                  | -                                  | -                                  | -  |
| Towels cycle                                      | -                                  | -                                  | ♦                                  | -                                  | -                                  | -  |
| Allergen cycle                                    | -                                  | -                                  | -                                  | ♦                                  | -                                  | -  |
| Sanitize cycle                                    | -                                  | <b>Eco with Oxi</b>                | <b>with Steam</b>                  | with Steam                         | with Steam                         | with Steam                                     |
| Clean Washer cycle with affresh® Washer cleaner   | -                                  | -                                  | -                                  | -                                  | -                                  | -  |
| EcoBoost™ option                                  | -                                  | -                                  | -                                  | ♦                                  | -                                  | -  |
| FanFresh® option with Dynamic Venting Technology® | -                                  | -                                  | -                                  | -                                  | 12-hour                            | 12-hour  |
| TumbleFresh™ option                               | -                                  | ♦                                  | -                                  | -                                  | -                                  | -  |
| Deep Clean option                                 | -                                  | -                                  | <b>with Steam</b>                  | with Steam                         | with Steam                         | with Steam                                     |
| Delay Wash option                                 | up to 8 hours                      | up to 8 hours                      | up to 8 hours                      | <b>up to 12 hours</b>              | up to 12 hours                     | up to 12 hours                                 |
| Presoak option                                    | -                                  | -                                  | ♦                                  | -                                  | -                                  | -  |
| Steam Clean option                                | -                                  | -                                  | ♦                                  | -                                  | -                                  | -  |
| <b>ACCESSORIES</b>                                |                                    |                                    |                                    |                                    |                                    |  |
| Pedestal  | XHPC155X                           | XHPC155X                           | XHPC155X/Y                         | XHPC155X/Y                         | XHPC155X/Y                         | XHPC155X/Y                                     |
| Washer detergent cartridge                        | -                                  | -                                  | -                                  | -                                  | -                                  | W10250743A                                     |
| 5' Washer Inlet Hose kit (2 pack)                 | 8212641RP                          | 8212641RP                          | 8212641RP                          | 8212641RP                          | 8212641RP                          | 8212641RP                                      |
| Washer drip tray                                  | 8212526                            | 8212526                            | 8212526                            | 8212526                            | 8212526                            | 8212526  |
| <b>DIMENSIONS AND COLORS</b>                      |                                    |                                    |                                    |                                    |                                    |  |
| Max height (A)                                    | 39 3/4"                            | 39 3/4"                            | 39 3/4"                            | 39 3/4"                            | 39 3/4"                            | 39 3/4"  |
| Width (B)   | 27"                                | 27"                                | 27"                                | 27"                                | 27"                                | 27"  |
| Depth (C)   | 33 1/8"                            | 33 1/8"                            | 33 1/8"                            | 33 1/8"                            | 33 1/8"                            | 33 1/8"  |
| Depth with door open (D)                          | 52 3/4"                            | 52 3/4"                            | 52 3/4"                            | 52 3/4"                            | 52 3/4"                            | 52 3/4"  |
| Available colors                                  | W                                  | W                                  | W   C                              | W   C                              | W   C                              | W   C   U                                      |

Bold type indicates a step-up feature

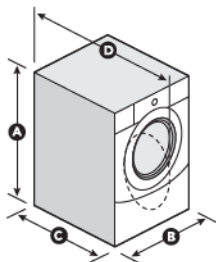

\*Based on the Consortium for Energy Efficiency qualifying product lists. Visit [cee1.org](http://cee1.org) for more information.  
\*\*Compared to pre-2004 traditional top load washers.

DIMENSIONS ARE SHOWN FOR PLANNING PURPOSES ONLY.  
For complete information, see Installation Instructions packed with product.



# Duet® HE Dryers

## SPECIFICATIONS AND DIMENSIONS

| DRYER MODEL   | WHIRLPOOL®           |                      |                      |                                     |                              |                              |                              |
|---|----------------------|----------------------|----------------------|-------------------------------------|------------------------------|------------------------------|------------------------------|
|   | WED70HEB<br>WGD70HEB | WED71HEB<br>WFW70HEB | WED80HEB<br>WGD80HEB | WED86HEB<br>WGD86HEB                | WED88HEA<br>WGD88HEA         | WED94HEA<br>WGD94HEA         | WED96HEA<br>WGD96HEA         |
| RECOMMENDED WASHER  | WFW70HEB             | WFW70HEB             | WFW80HEB             | WFW86HEB                            | WFW88HEA                     | WFW94HEA                     | WFW96HEA                     |
| <b>New 2013 model</b>   | -                    | -                    | -                    | -                                   | -                            | -                            | -                            |
| Capacity (cu. ft.)  | 7.4                  | 7.4                  | 7.4                  | 7.4                                 | 7.4                          | 7.4                          | 7.4                          |
| High-efficiency dryer   | -                    | -                    | -                    | -                                   | -                            | -                            | -                            |
| Tap Touch controls  | -                    | -                    | -                    | -                                   | -                            | -                            | -                            |
| Estimated time remaining LED display  | -                    | -                    | -                    | -                                   | -                            | -                            | -                            |
| Eco Monitor   | -                    | -                    | ♦                    | -                                   | -                            | -                            | -                            |
| Damp Dry signal   | -                    | -                    | <b>Loud/Soft/Off</b> | Loud/Soft/Off                       | Loud/Soft/Off                | Loud/Soft/Off                | Loud/Soft/Off                |
| End-of-cycle signal   | -                    | -                    | <b>On/Off</b>        | On/Off                              | On/Off                       | On/Off                       | On/Off                       |
| Dryer drum  | Powder coated        | Powder coated        | Powder coated        | Powder coated                       | <b>Stainless steel</b>       | Stainless steel              | <b>SilentSteel™</b>          |
| Drum light  | -                    | -                    | ♦                    | <b>LED</b>                          | LED                          | LED                          | LED                          |
| Quad baffles  | -                    | -                    | -                    | -                                   | -                            | -                            | -                            |
| Long vent   | -                    | ♦                    | -                    | -                                   | -                            | -                            | -                            |
| Designed, engineered and assembled in the U.S.A.  | -                    | -                    | -                    | -                                   | -                            | -                            | -                            |
| <b>DRYING SYSTEM</b>  |                      |                      |                      |                                     |                              |                              |                              |
| Advanced Moisture Sensing   | -                    | -                    | -                    | -                                   | -                            | -                            | -                            |
| Quiet Dry Ultra system  | -                    | -                    | -                    | -                                   | -                            | -                            | -                            |
| Timed dry   | -                    | -                    | -                    | -                                   | -                            | -                            | -                            |
| Total number of temperatures  | 4                    | 4                    | 4                    | 5                                   | 5                            | 5                            | 5                            |
| <b>CYCLES AND OPTIONS</b>   |                      |                      |                      |                                     |                              |                              |                              |
| Total number of cycles  | 6                    | 6                    | 7                    | 9                                   | 10                           | 10                           | 10                           |
| Steam-enhanced cycles   | -                    | -                    | -                    | -                                   | ♦                            | -                            | -                            |
| Quick Dry cycle   | -                    | -                    | -                    | -                                   | -                            | -                            | -                            |
| Delicate cycle  | -                    | -                    | -                    | -                                   | -                            | -                            | -                            |
| Casual cycle  | -                    | -                    | ♦                    | -                                   | -                            | -                            | -                            |
| Normal cycle  | -                    | -                    | -                    | -                                   | -                            | -                            | -                            |
| Bulky Items cycle   | -                    | -                    | -                    | -                                   | -                            | -                            | -                            |
| Heavy Duty cycle  | -                    | -                    | -                    | -                                   | -                            | -                            | -                            |
| Towels cycle  | -                    | -                    | -                    | -                                   | ♦                            | -                            | -                            |
| Sanitize cycle  | -                    | -                    | -                    | ♦                                   | -                            | -                            | -                            |
| Steam Refresh cycle   | -                    | -                    | -                    | ♦                                   | -                            | -                            | -                            |
| EcoBoost™ option  | -                    | -                    | -                    | -                                   | ♦                            | -                            | -                            |
| Wrinkle Shield™ Plus option   | up to 140 minutes    | up to 140 minutes    | up to 140 minutes    | <b>up to 140 minutes with Steam</b> | up to 140 minutes with Steam | up to 140 minutes with Steam | up to 140 minutes with Steam |
| Static Reduce option  | -                    | -                    | -                    | -                                   | -                            | ♦                            | -                            |
| <b>ACCESSORIES</b>  |                      |                      |                      |                                     |                              |                              |                              |
| Pedestal  | XHPC155X             | XHPC155X             | XHPC155X             | XHPC155X/Y                          | XHPC155X/Y                   | XHPC155X/Y                   | XHPC155X/Y                   |
| Dryer rack  | W10322470A           | W10322470A           | W10322470A           | W10322470A                          | W10322470A                   | W10322470A                   | W10322470A                   |
| Duet® Stack kit   | W10298318RP          | W10298318RP          | W10298318RP          | W10298318RP                         | W10298318RP                  | W10298318RP                  | W10298318RP                  |
| 4-Way Internal Vent Kit back (standard), left/right/bottom, universal color midnight grey | W10323246            | W10323246            | W10323246            | W10323246                           | W10323246                    | W10323246                    | W10323246                    |
| LP Gas Conversion kit   | W10307153            | W10307153            | W10307153            | W10307153                           | W10307153                    | W10307153                    | W10307153                    |
| 4" Gas Dryer Hook-Up kit  | 20-48KITRC           | 20-48KITRC           | 20-48KITRC           | 20-48KITRC                          | 20-48KITRC                   | 20-48KITRC                   | 20-48KITRC                   |
| 4', 3-wire, 30 amp dryer cord   | PT220L               | PT220L               | PT220L               | PT220L                              | PT220L                       | PT220L                       | PT220L                       |
| 4', 4-wire, 30 amp dryer cord   | PT400L               | PT400L               | PT400L               | PT400L                              | PT400L                       | PT400L                       | PT400L                       |
| 6', 3-wire, 30 amp dryer cord   | PT500L               | PT500L               | PT500L               | PT500L                              | PT500L                       | PT500L                       | PT500L                       |
| 6', 4-wire, 30 amp dryer cord   | PT600L               | PT600L               | PT600L               | PT600L                              | PT600L                       | PT600L                       | PT600L                       |
| <b>DIMENSIONS AND COLORS</b>  |                      |                      |                      |                                     |                              |                              |                              |
| Max height (A)  | 39 1/4"              | 39 1/4"              | 39 1/4"              | 39 1/4"                             | 39 1/4"                      | 39 1/4"                      | 39 1/4"                      |
| Width (B)   | 27"                  | 27"                  | 27"                  | 27"                                 | 27"                          | 27"                          | 27"                          |
| Depth (C)   | 33 1/8"              | 33 1/8"              | 33 1/8"              | 33 1/8"                             | 33 1/8"                      | 33 1/8"                      | 33 1/8"                      |
| Depth with door open (D)  | 52 1/4"              | 52 1/4"              | 52 1/4"              | 52 1/4"                             | 52 1/4"                      | 52 1/4"                      | 52 1/4"                      |
| Available colors  | W                    | W                    | W                    | W   C                               | W   C                        | W   C                        | W   C   U                    |

Bold type indicates a step-up feature

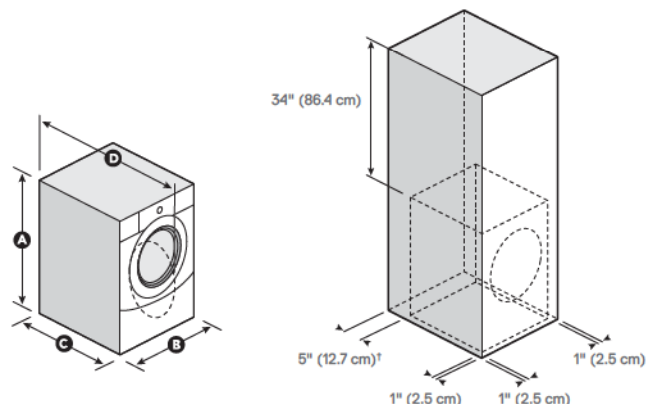

†Add 5-1/2" for proper venting of gas dryers.

DIMENSIONS ARE SHOWN FOR PLANNING PURPOSES ONLY.  
For complete information, see Installation Instructions packed with product.

# Cabrio® HE Top Load Washers

## SPECIFICATIONS AND DIMENSIONS

| WASHER MODEL<br>RECOMMENDED DRYER                 | WHIRLPOOL®                         |                                    |
|---|------------------------------------|------------------------------------|
|   | WTW5500B<br>WE/GD5500B             | WTW5800B<br>WE/GD5800B             |
| New 2013 model                                    | -                                  | -                                  |
| Capacity (cu. ft.)                                | 3.8                                | 3.8                                |
| High-efficiency washer                            | -                                  | -                                  |
| ENERGY STAR® qualified                            | -                                  | -                                  |
| Meets CEE Tier standards*                         | Tier 3                             | Tier 3                             |
| Water use/Energy use**                            | 74% less / 81% less                | 74% less / 81% less                |
| Cycle status bar                                  | -                                  | -                                  |
| Estimated time remaining LED display              | -                                  | ♦                                  |
| Eco Monitor                                       | -                                  | ♦                                  |
| End-of-cycle signal                               | -                                  | <b>Loud/Soft/Off</b>               |
| Lid   | Wide open                          | <b>EasyView™ framed glass</b>      |
| Smooth Spiral stainless steel wash basket         | -                                  | -                                  |
| Designed, engineered and assembled in the U.S.A.  | -                                  | -                                  |
| <b>WASH SYSTEM</b>                                |                                    |                                    |
| Adaptive Wash technology                          | -                                  | -                                  |
| Adaptive wash actions                             | 5                                  | 5                                  |
| Precision Dispense                                | -                                  | -                                  |
| Automatic dispensers                              | Detergent, bleach, fabric softener | Detergent, bleach, fabric softener |
| Care Control temperature management system        | -                                  | -                                  |
| Quiet Spin technology                             | -                                  | -                                  |
| Quiet Wash noise reduction system                 | -                                  | -                                  |
| Max spin speed (RPM)                              | up to 800                          | up to 800                          |
| Total number of water levels                      | Auto Load Sensing                  | Auto Load Sensing                  |
| Wash action                                       | Smooth impeller                    | Smooth impeller                    |
| Total number of temperatures                      | 5                                  | 5                                  |
| <b>CYCLES AND OPTIONS</b>                         |                                    |                                    |
| Total number of cycles                            | 11                                 | <b>13</b>                          |
| Quick Wash cycle                                  | -                                  | -                                  |
| Delicate cycle                                    | -                                  | -                                  |
| Normal cycle                                      | -                                  | -                                  |
| Casual cycle                                      | -                                  | -                                  |
| Cold Wash cycle                                   | -                                  | -                                  |
| Bulky Items cycle                                 | -                                  | -                                  |
| Super Wash cycle                                  | -                                  | -                                  |
| Whites cycle                                      | -                                  | ♦                                  |
| Clean Washer cycle with affresh® Washer cleaner   | -                                  | -                                  |
| Deep Water Wash cycle                             | -                                  | -                                  |
| Soak cycle  | -                                  | ♦                                  |
| EcoBoost™ option                                  | -                                  | ♦                                  |
| Deep Clean option                                 | -                                  | ♦                                  |
| Delay Wash option                                 | -                                  | <b>up to 9 hours</b>               |
| Extra Rinse option                                | -                                  | -                                  |
| Presoak option                                    | -                                  | ♦                                  |
| <b>ACCESSORIES</b>                                |                                    |                                    |
| 5' Washer Inlet Hose kit (2-pack)                 | 8212641RP                          | 8212641RP                          |
| 5' Nylon Braided Washer Fill Hose kit (2-pack)    | 8212487RP                          | 8212487RP                          |
| 6' Gooseneck Nylon Braided Fill Hose kit (2-pack) | 8212638RP                          | 8212638RP                          |
| 10' Washer Inlet Hose kit (2-pack)                | 8212656RP                          | 8212656RP                          |
| Washer drip tray                                  | 8212526                            | 8212526                            |
| <b>DIMENSIONS AND COLORS</b>                      |                                    |                                    |
| Max height (A)                                    | 43½"                               | 43½"                               |
| Width (B)   | 27½"                               | 27½"                               |
| Depth (C)   | 27"                                | 27"                                |
| Height with lid open (D)                          | 53½"                               | 53½"                               |
| Top height (E)                                    | 36½"                               | 36½"                               |
| Available colors                                  | W                                  | W   C                              |

Bold type indicates a step-up feature

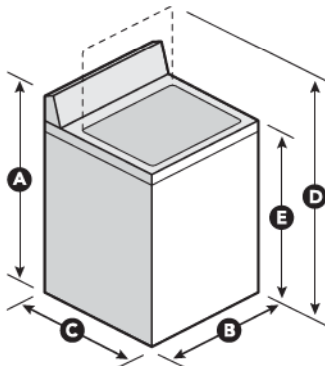

\*Based on the Consortium for Energy Efficiency qualifying product lists. Visit [cee1.org](http://cee1.org) for more information.  
\*\*Compared to pre-2004 traditional top load washers.

DIMENSIONS ARE SHOWN FOR PLANNING PURPOSES ONLY.  
For complete information, see Installation Instructions packed with product.

# Cabrio® HE Dryers

## SPECIFICATIONS AND DIMENSIONS

| WHIRLPOOL®  |                      |                           |
|---|----------------------|---------------------------|
| DRYER MODEL   | WED5500B<br>WGD5500B | WED5800B<br>WGD5800B      |
| RECOMMENDED WASHER  | WTW5500B             | WTW5800B                  |
| New 2013 model  | -                    | -                         |
| Capacity (cu. ft.)  | 7.4                  | 7.4                       |
| High-efficiency dryer   | -                    | -                         |
| Estimated time remaining LED display  | -                    | ♦                         |
| Eco Monitor   | -                    | ♦                         |
| Damp Dry signal   | -                    | ♦                         |
| End-of-cycle signal   | On/Off               | <b>Loud/Soft/Off</b>      |
| Drum light  | -                    | <b>On/Off</b>             |
| Door style  | Hamper               | <b>Hamper with window</b> |
| Designed, engineered and assembled in the U.S.A.  | -                    | -                         |
| DRYING SYSTEM   |                      |                           |
| AccuDry™ sensor drying system   | -                    | -                         |
| Quiet Dry noise reduction system  | -                    | -                         |
| Timed dry   | -                    | -                         |
| 4-way venting   | -                    | -                         |
| Total number of temperatures  | 4                    | 5                         |
| CYCLES AND OPTIONS  |                      |                           |
| Total number of cycles  | 10                   | 9                         |
| Sanitize cycle  | -                    | ♦                         |
| Quick Dry cycle   | -                    | ♦                         |
| Delicate cycle  | -                    | ♦                         |
| Normal cycle  | -                    | -                         |
| Eco Normal cycle  | -                    | ♦                         |
| Casual cycle  | -                    | ♦                         |
| Less Dry cycle  | -                    | -                         |
| Heavy Duty cycle  | -                    | ♦                         |
| Wrinkle Shield™ option  | up to 90 minutes     | <b>up to 150 minutes</b>  |
| ACCESSORIES   |                      |                           |
| Dryer rack  | 8212450A             | 8212450A                  |
| 4-Way Internal Vent Kit Back (standard), left/right/bottom, universal color midnight grey | W10186596            | W10186596                 |
| LP Gas Conversion kit   | W10317689            | W10317689                 |
| 4" Gas Dryer Hook-Up kit  | 20-48KITRC           | 20-48KITRC                |
| 4', 3-wire, 30 amp dryer cord   | PT220L               | PT220L                    |
| 4', 4-wire, 30 amp dryer cord   | PT400L               | PT400L                    |
| 6', 3-wire, 30 amp dryer cord   | PT500L               | PT500L                    |
| 6', 4-wire, 30 amp dryer cord   | PT600L               | PT600L                    |
| DIMENSIONS AND COLORS   |                      |                           |
| Max height (A)  | 43½"                 | 43½"                      |
| Width (B)   | 27"                  | 27"                       |
| Depth (C)   | 29½"                 | 29½"                      |
| Depth with door open (D)  | 43¼"                 | 43¼"                      |
| Top height (E)  | 36¼"                 | 36¼"                      |
| Available colors  | W                    | W   C                     |

Bold type indicates a step-up feature

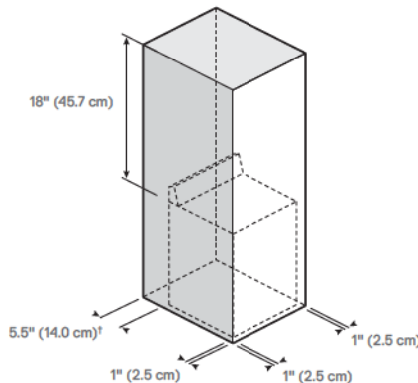
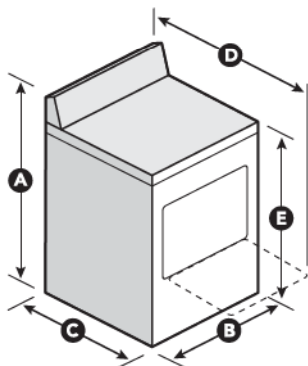

†Add 5-1/2" for proper venting of gas dryers.

DIMENSIONS ARE SHOWN FOR PLANNING PURPOSES ONLY. For complete information, see Installation Instructions packed with product.

# Cabrio® Platinum HE Top Load Washers

## SPECIFICATIONS AND DIMENSIONS

| WASHER MODEL<br>RECOMMENDED DRYER                 | WHIRLPOOL®                         |                                    |                                    |  |
|---|------------------------------------|------------------------------------|------------------------------------|--|
|   | WTW8000B<br>WE/GD8000B             | WTW8100B<br>WE/GD8100B             | WTW8500B<br>WE/GD8500B             | WTW8900B<br>WE/GD8900B                                 |
| New 2013 model                                    | -                                  | -                                  | -                                  | -  |
| Capacity (cu. ft.)                                | 4.5                                | 4.5                                | 4.8                                | 4.8  |
| High-efficiency washer                            | -                                  | -                                  | -                                  | -  |
| ENERGY STAR® qualified                            | -                                  | -                                  | -                                  | -  |
| Meets CEE Tier standards*                         | Tier 3                             | Tier 3                             | Tier 3                             | Tier 3   |
| Water use/Energy use**                            | 74% less / <b>82% less</b>         | 74% less / 82% less                | 74% less / 82% less                | 74% less / 82% less                                    |
| Estimated time remaining LED display              | -                                  | -                                  | -                                  | -  |
| Eco Monitor                                       | -                                  | -                                  | -                                  | -  |
| End-of-cycle signal                               | On/Off                             | On/Off                             | <b>Loud/Soft/Off</b>               | Loud/Soft/Off  |
| Lid   | Wide open                          | <b>EasyView™ framed glass</b>      | EasyView™ framed glass             | <b>EasyView™ frameless glass with slow-close hinge</b> |
| Interior LED light                                | -                                  | -                                  | -                                  | ♦  |
| Smooth Spiral stainless steel wash basket         | -                                  | -                                  | -                                  | -  |
| Chrome accents                                    | -                                  | -                                  | -                                  | ♦  |
| Designed, engineered and assembled in the U.S.A.  | -                                  | -                                  | -                                  | -  |
| <b>WASH SYSTEM</b>                                |                                    |                                    |                                    |  |
| Adaptive Wash technology                          | -                                  | -                                  | -                                  | -  |
| Adaptive wash actions                             | <b>11</b>                          | 11                                 | 11                                 | 11   |
| Precision Dispense                                | <b>Plus</b>                        | Plus                               | Plus                               | Plus   |
| Automatic dispensers                              | Detergent, bleach, fabric softener | Detergent, bleach, fabric softener | Detergent, bleach, fabric softener | Detergent, oxl/bleach, fabric softener                 |
| Care Control temperature management system        | -                                  | -                                  | -                                  | -  |
| Quiet Spin technology                             | -                                  | -                                  | -                                  | -  |
| Quiet Wash noise reduction system                 | <b>Ultra</b>                       | Ultra                              | Ultra                              | Ultra  |
| Max spin speed (RPM)                              | <b>up to 1,100</b>                 | up to 1,100                        | up to 1,100                        | up to 1,100  |
| Total number of water levels                      | Auto Load Sensing                  | Auto Load Sensing                  | Auto Load Sensing                  | Auto Load Sensing                                      |
| Wash action                                       | Smooth impeller                    | Smooth impeller                    | <b>Unique soft-touch impeller</b>  | Unique soft-touch impeller                             |
| Direct drive motor                                | ♦                                  | -                                  | -                                  | -  |
| Total number of temperatures                      | 4                                  | 4                                  | 4                                  | 5  |
| Water heater                                      | -                                  | -                                  | ♦                                  | -  |
| <b>CYCLES AND OPTIONS</b>                         |                                    |                                    |                                    |  |
| Total number of cycles                            | 11                                 | 11                                 | 13                                 | 16   |
| Quick Wash cycle                                  | -                                  | -                                  | -                                  | -  |
| Delicate cycle                                    | -                                  | -                                  | -                                  | -  |
| Active Wear cycle                                 | -                                  | -                                  | ♦                                  | -  |
| Sheets cycle                                      | ♦                                  | -                                  | -                                  | -  |
| Towels cycle                                      | -                                  | -                                  | -                                  | ♦  |
| Casual cycle                                      | -                                  | -                                  | -                                  | -  |
| Normal cycle                                      | -                                  | -                                  | -                                  | -  |
| Cold Wash cycle                                   | -                                  | -                                  | ♦                                  | -  |
| Bulky Items cycle                                 | -                                  | -                                  | -                                  | -  |
| Whites cycle                                      | -                                  | -                                  | -                                  | -  |
| Allergen cycle                                    | -                                  | -                                  | -                                  | ♦  |
| Sanitary cycle with Steam and Oxi                 | -                                  | -                                  | -                                  | ♦  |
| Clean Washer cycle with affresh® Washer cleaner   | -                                  | -                                  | -                                  | -  |
| Deep Water Soak cycle                             | -                                  | -                                  | -                                  | ♦  |
| Heavy Duty cycle                                  | ♦                                  | -                                  | -                                  | -  |
| Soak cycle  | -                                  | -                                  | ♦                                  | -  |
| EcoBoost™ option                                  | -                                  | -                                  | -                                  | -  |
| Deep Clean option                                 | -                                  | -                                  | -                                  | <b>with Heater</b>                                     |
| Oxi Dispense option                               | -                                  | -                                  | -                                  | ♦  |
| Delay Wash option                                 | up to 8 hours                      | <b>up to 10 hours</b>              | <b>up to 12 hours</b>              | up to 12 hours   |
| Extra rinse option                                | -                                  | -                                  | -                                  | -  |
| <b>ACCESSORIES</b>                                |                                    |                                    |                                    |  |
| 5' Washer Inlet Hose kit (2-pack)                 | 8212641RP                          | 8212641RP                          | 8212641RP                          | 8212641RP  |
| 5' Nylon Braided Washer Fill Hose kit (2-pack)    | 8212487RP                          | 8212487RP                          | 8212487RP                          | 8212487RP  |
| 6' Gooseneck Nylon Braided Fill Hose kit (2-pack) | 8212638RP                          | 8212638RP                          | 8212638RP                          | 8212638RP  |
| 10' Washer Inlet Hose kit (2-pack)                | 8212656RP                          | 8212656RP                          | 8212656RP                          | 8212656RP  |
| Washer drip tray                                  | 8212526                            | 8212526                            | 8212526                            | 8212526  |
| <b>DIMENSIONS AND COLORS</b>                      |                                    |                                    |                                    |  |
| Max height (A)                                    | 44"                                | 44"                                | 45½"                               | 45½"   |
| Width (B)   | 27½"                               | 27½"                               | 27½"                               | 27½"   |
| Depth (C)   | 27½"                               | 27½"                               | 27½"                               | 27½"   |
| Height with lid open (D)                          | 58"                                | 58"                                | 58½"                               | 58½"   |
| Top height (E)                                    | 39"                                | 39"                                | 39½"                               | 39½"   |
| Available colors                                  | W                                  | W                                  | W   C                              | W   C  |

Bold type indicates a step-up feature

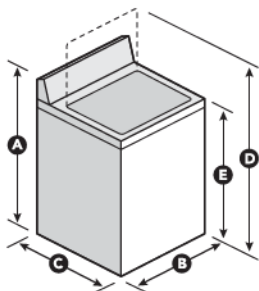

\*Based on the Consortium for Energy Efficiency qualifying product lists. Visit [cee1.org](http://cee1.org) for more information.  
\*\*Compared to pre-2004 traditional top load washers.

DIMENSIONS ARE SHOWN FOR PLANNING PURPOSES ONLY.  
For complete information, see installation instructions packed with product.

# Cabrio® Platinum HE Dryers

## SPECIFICATIONS AND DIMENSIONS

| DRYER MODEL                                      | WHIRLPOOL®                   |   |                                      |                                      |
|--|------------------------------|---|--------------------------------------|--------------------------------------|
|  | WED8000B<br>WGD8000B         | WED8100B<br>WGD8100B                        | WED8500B<br>WGD8500B                 | WED8900B<br>WGD8900B                 |
| RECOMMENDED WASHER                               | WTW8000B                     | WTW8100B                                    | WTW8500B                             | WTW8900B                             |
| New 2013 model                                   | -                            | -   | -                                    | -                                    |
| Capacity (cu. ft.)                               | 7.6                          | 7.6   | 7.6                                  | 7.6                                  |
| High-efficiency dryer                            | -                            | -   | -                                    | -                                    |
| Estimated time remaining LED display             | -                            | -   | -                                    | -                                    |
| Eco Monitor                                      | -                            | -   | -                                    | -                                    |
| Damp Dry signal                                  | On/Off                       | On/Off                                      | On/Off                               | On/Off                               |
| End-of-cycle signal                              | On/Off                       | On/Off                                      | <b>Loud/Soft/Off</b>                 | Loud/Soft/Off                        |
| Check vent indicator                             | ♦                            | -   | -                                    | -                                    |
| Drum light                                       | -                            | -   | -                                    | -                                    |
| Door style                                       | <b>Reversible side-swing</b> | Reversible side-swing<br><b>with window</b> | Reversible side-swing<br>with window | Reversible side-swing<br>with window |
| Chrome accents                                   | -                            | -   | -                                    | ♦                                    |
| Designed, engineered and assembled in the U.S.A. | -                            | -   | -                                    | -                                    |
| <b>DRYING SYSTEM</b>                             |                              |   |                                      |                                      |
| Advanced Moisture Sensing                        | ♦                            | -   | -                                    | -                                    |
| Quiet Dry Ultra noise reduction system           | ♦                            | -   | -                                    | -                                    |
| Venting options                                  | 2-way                        | 2-way                                       | 2-way                                | 2-way                                |
| Dual heating element                             | ♦                            | -   | -                                    | -                                    |
| Y connector                                      | -                            | -   | ♦                                    | -                                    |
| Timed dry  | -                            | -   | -                                    | -                                    |
| Total number of temperatures                     | 5                            | 5   | 5                                    | 5                                    |
| <b>CYCLES AND OPTIONS</b>                        |                              |   |                                      |                                      |
| Total number of cycles                           | <b>9</b>                     | 9   | <b>11</b>                            | <b>14</b>                            |
| Steam-enhanced cycles                            | -                            | -   | ♦                                    | -                                    |
| Sanitize cycle                                   | -                            | -   | -                                    | -                                    |
| Quick Dry cycle                                  | -                            | -   | -                                    | -                                    |
| Quick Refresh Steam cycle                        | -                            | -   | -                                    | ♦                                    |
| Enhanced Touch Up Steam cycle                    | -                            | -   | ♦                                    | -                                    |
| Delicate cycle                                   | -                            | -   | -                                    | -                                    |
| Active Wear cycle                                | -                            | -   | ♦                                    | -                                    |
| Sheets cycle                                     | -                            | -   | ♦                                    | -                                    |
| Bulky Items cycle                                | ♦                            | -   | -                                    | -                                    |
| Casual cycle                                     | -                            | -   | -                                    | -                                    |
| Normal cycle                                     | -                            | -   | -                                    | -                                    |
| Towels cycle                                     | -                            | -   | -                                    | ♦                                    |
| Jeans cycle                                      | -                            | -   | -                                    | ♦                                    |
| Heavy Duty cycle                                 | -                            | -   | -                                    | -                                    |
| EcoBoost™ option                                 | -                            | -   | -                                    | -                                    |
| Wrinkle Shield™ Plus option                      | -                            | -   | -                                    | <b>up to 150 minutes with Steam</b>  |
| Wrinkle Shield™ option                           | up to 150 minutes            | up to 150 minutes                           | up to 150 minutes                    | -                                    |
| Static Reduce option                             | -                            | -   | -                                    | ♦                                    |
| <b>ACCESSORIES</b>                               |                              |   |                                      |                                      |
| Dryer rack                                       | 8577312A                     | 8577312A                                    | 8577312A                             | 8577312A                             |
| LP Gas Conversion kit                            | W10317689                    | W10317689                                   | W10317689                            | W10317689                            |
| 4' Gas Dryer Hook-Up kit                         | 20-48KITRC                   | 20-48KITRC                                  | 20-48KITRC                           | 20-48KITRC                           |
| 4', 3-wire, 30 amp dryer cord                    | PT220L                       | PT220L                                      | PT220L                               | PT220L                               |
| 4', 4-wire, 30 amp dryer cord                    | PT400L                       | PT400L                                      | PT400L                               | PT400L                               |
| 6', 3-wire, 30 amp dryer cord                    | PT500L                       | PT500L                                      | PT500L                               | PT500L                               |
| 6', 4-wire, 30 amp dryer cord                    | PT600L                       | PT600L                                      | PT600L                               | PT600L                               |
| <b>DIMENSIONS AND COLORS</b>                     |                              |   |                                      |                                      |
| Max height (A)                                   | 44"                          | 44"   | 45½"                                 | 45½"                                 |
| Width (B)  | 29"                          | 29"   | 29"                                  | 29"                                  |
| Depth (C)  | 29¼"                         | 29¼"  | 29¼"                                 | 29¼"                                 |
| Depth with door open (D)                         | 52½"                         | 52½"  | 52½"                                 | 52½"                                 |
| Top height (E)                                   | 39"                          | 39"   | 39½"                                 | 39½"                                 |
| Available colors                                 | W                            | W   | W   C                                | W   C                                |

Bold type indicates a step-up feature

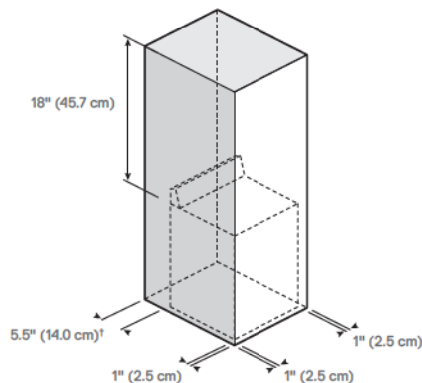
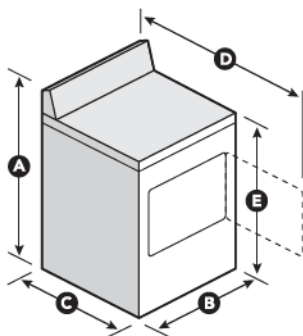

†Add 5-1/2" for proper venting of gas dryers.

DIMENSIONS ARE SHOWN FOR PLANNING PURPOSES ONLY.  
For complete information, see Installation Instructions packed with product.



# Traditional Top Load Washers

## SPECIFICATIONS AND DIMENSIONS

| WASHER MODEL                                      | WHIRLPOOL®              |                                      |                                      |
|---|-------------------------|--------------------------------------|--------------------------------------|
|   | WTW4800B                | WTW4850B<br>WE/GD4850B<br>WE/GD4890B | WTW4900B<br>WE/GD4850B<br>WE/GD4890B |
| <b>RECOMMENDED DRYERS</b>                         | <b>WE/GD4800B</b>       |                                      |                                      |
| New 2013 model                                    | -                       | -                                    | -                                    |
| Capacity (cu. ft.)                                | 3.6                     | 3.6                                  | 3.8                                  |
| High-efficiency washer                            | -                       | -                                    | ♦                                    |
| ENERGY STAR® qualified                            | -                       | ♦                                    | -                                    |
| Meets CEE Tier standards*                         | -                       | -                                    | <b>Tier 3</b>                        |
| Water use/Energy use**                            | -                       | <b>60% less / 77% less</b>           | <b>74% less / 81% less</b>           |
| Cycle status bar                                  | -                       | -                                    | -                                    |
| Wide open lid                                     | -                       | -                                    | -                                    |
| Wash basket                                       | White porcelain         | White porcelain                      | <b>Smooth Spiral stainless steel</b> |
| Designed, engineered and assembled in the U.S.A.  | -                       | -                                    | -                                    |
| <b>WASH SYSTEM</b>                                |                         |                                      |                                      |
| Fabric Sense™ wash system                         | -                       | -                                    | -                                    |
| Adaptive wash actions                             | -                       | -                                    | <b>5</b>                             |
| Additive dispensers                               | Bleach, fabric softener | Bleach, fabric softener              | Bleach                               |
| Care Control temperature management system        | -                       | -                                    | -                                    |
| Quiet Spin technology                             | -                       | -                                    | -                                    |
| Max spin speed (RPM)                              | up to 700               | <b>up to 800</b>                     | up to 800                            |
| Total number of water levels                      | 4                       | <b>Auto Load Sensing</b>             | Auto Load Sensing                    |
| Wash action                                       | Smooth motion agitator  | Smooth motion agitator               | <b>Smooth impeller</b>               |
| Total number of temperatures                      | 5                       | 5                                    | 5                                    |
| <b>CYCLES AND OPTIONS</b>                         |                         |                                      |                                      |
| Total number of cycles                            | 9                       | <b>12</b>                            | 12                                   |
| Quick Wash cycle                                  | -                       | ♦                                    | -                                    |
| Delicate cycle                                    | -                       | -                                    | -                                    |
| Casual cycle                                      | -                       | -                                    | -                                    |
| Cold Wash cycle                                   | -                       | ♦                                    | -                                    |
| Normal cycle                                      | -                       | -                                    | -                                    |
| Deep Water Wash cycle                             | -                       | ♦                                    | -                                    |
| Bulky Items/Sheets cycle                          | -                       | ♦                                    | -                                    |
| Clean Washer cycle with affresh® Washer cleaner   | -                       | -                                    | -                                    |
| Heavy Duty cycle                                  | -                       | ♦                                    | -                                    |
| Soak cycle  | -                       | ♦                                    | -                                    |
| Extra Rinse option                                | -                       | -                                    | -                                    |
| Extra Large Load Size option                      | -                       | -                                    | -                                    |
| Presoak option                                    | -                       | ♦                                    | -                                    |
| <b>ACCESSORIES</b>                                |                         |                                      |                                      |
| 5' Washer Inlet Hose kit (2-pack)                 | 8212641RP               | 8212641RP                            | 8212641RP                            |
| 5' Nylon Braided Washer Fill Hose kit (2-pack)    | 8212487RP               | 8212487RP                            | 8212487RP                            |
| 6' Gooseneck Nylon Braided Fill Hose kit (2-pack) | 8212638RP               | 8212638RP                            | 8212638RP                            |
| 10' Washer Inlet Hose kit (2-pack)                | 8212656RP               | 8212656RP                            | 8212656RP                            |
| Washer drip tray                                  | 8212526                 | 8212526                              | 8212526                              |
| <b>DIMENSIONS AND COLORS</b>                      |                         |                                      |                                      |
| Max height (A)                                    | 43"                     | 43"                                  | 43"                                  |
| Width (B)   | 27½"                    | 27½"                                 | 27½"                                 |
| Depth (C)   | 27"                     | 27"                                  | 27"                                  |
| Height with door open (D)                         | 53"                     | 53"                                  | 53"                                  |
| Top height (E)                                    | 36"                     | 36"                                  | 36"                                  |
| Available colors                                  | Q                       | W                                    | W                                    |

Bold type indicates a step-up feature

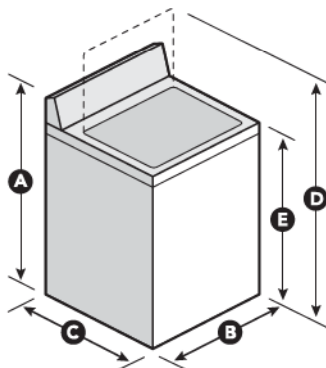

\*Based on the Consortium for Energy Efficiency qualifying product lists. Visit [cee1.org](http://cee1.org) for more information.  
\*\*Compared to pre-2004 traditional top load washers.

DIMENSIONS ARE SHOWN FOR PLANNING PURPOSES ONLY.  
For complete information, see Installation Instructions packed with product.

# Traditional Dryers

## SPECIFICATIONS AND DIMENSIONS

| DRYER MODEL                                      | WHIRLPOOL®            |                      |                       |
|--|-----------------------|----------------------|-----------------------|
|  | WED4800B<br>WGD4800B  | WED4850B<br>WGD4850B | WED4890B<br>WGD4890B  |
| RECOMMENDED WASHERS                              | WTW4800B              | WTW4850B<br>WTW4900B | WTW4850B<br>WTW4900B  |
| New 2013 model                                   | -                     | -                    | -                     |
| Capacity (cu. ft.)                               | 7.0                   | 7.0                  | 6.4                   |
| High-efficiency dryer                            | -                     | ♦                    | -                     |
| On/Off end-of-cycle signal                       | -                     | -                    | -                     |
| Drum light                                       | -                     | ♦                    | -                     |
| Door style                                       | Reversible side-swing | Wide-opening hamper  | Reversible side-swing |
| Smooth, flat back design                         | -                     | -                    | ♦                     |
| Designed, engineered and assembled in the U.S.A. | -                     | -                    | -                     |
| <b>DRYING SYSTEM</b>                             |                       |                      |                       |
| AccuDry™ sensor drying system                    | -                     | ♦                    | -                     |
| AutoDry™ drying system                           | -                     | -                    | -                     |
| Timed Dry  | -                     | -                    | -                     |
| Total number of temperatures                     | 5                     | 5                    | 5                     |
| <b>CYCLES AND OPTIONS</b>                        |                       |                      |                       |
| Total number of cycles                           | 15                    | 12                   | 12                    |
| Very Dry cycle                                   | -                     | -                    | -                     |
| Delicate cycle                                   | -                     | ♦                    | -                     |
| Jeans cycle                                      | -                     | ♦                    | -                     |
| Less Dry cycle                                   | -                     | -                    | -                     |
| Energy Preferred cycles                          | -                     | -                    | -                     |
| Heavy Dry cycle                                  | -                     | -                    | -                     |
| Wrinkle Shield™ option                           | up to 40 minutes      | up to 90 minutes     | up to 90 minutes      |
| <b>ACCESSORIES</b>                               |                       |                      |                       |
| Dryer rack                                       | 3406839               | 3406839              | -                     |
| LP Gas Conversion kit                            | 49572                 | 49572                | 49572                 |
| 4' Gas Dryer Hook-Up kit                         | 20-48KITRC            | 20-48KITRC           | 20-48KITRC            |
| 4', 3-wire, 30 amp dryer cord                    | PT220L                | PT220L               | PT220L                |
| 4', 4-wire, 30 amp dryer cord                    | PT400L                | PT400L               | PT400L                |
| 6', 3-wire, 30 amp dryer cord                    | PT500L                | PT500L               | PT500L                |
| 6', 4-wire, 30 amp dryer cord                    | PT600L                | PT600L               | PT600L                |
| <b>DIMENSIONS AND COLORS</b>                     |                       |                      |                       |
| Max height (A)                                   | 43"                   | 43"                  | 43"                   |
| Width (B)  | 29"                   | 29"                  | 29"                   |
| Depth (C)  | 29½"                  | 29½"                 | 25½"                  |
| Depth with door open (D)                         | 50½"                  | 42"                  | 50½"                  |
| Top height (E)                                   | 36"                   | 36"                  | 36"                   |
| Available colors                                 | Q                     | W                    | W                     |

Bold type indicates a step-up feature

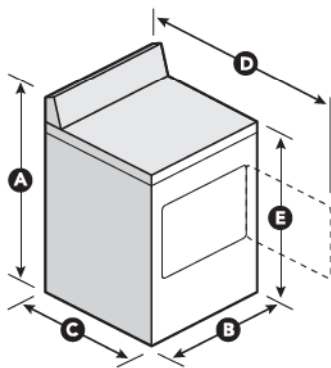

Reversible side-swing door

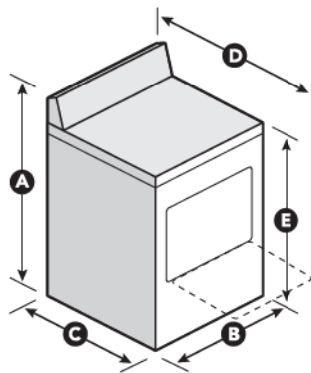

Wide-opening hamper door

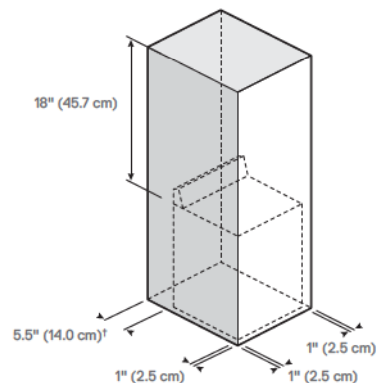

†Add 5-1/2" for proper venting of gas dryers.

DIMENSIONS ARE SHOWN FOR PLANNING PURPOSES ONLY.  
For complete information, see Installation Instructions packed with product.

# Thin Twin® Laundry Centers

## SPECIFICATIONS AND DIMENSIONS

|  | WHIRLPOOL®           |                                |
|--|----------------------|--------------------------------|
| MODEL  | LTE/G5243D           | WE/GT3300X                     |
| Washer capacity (cu. ft.)  | 1.5                  | 2.5                            |
| Thin Twin® Laundry Center  | -                    | -                              |
| Tough Top™ II top and lid  | -                    | -                              |
| Wash basket  | Spreckle             | White porcelain                |
| Designed, engineered and assembled in the U.S.A.                 | -                    | -                              |
| <b>WASH SYSTEM</b>   |                      |                                |
| Additive dispensers  | -                    | Bleach, fabric softener        |
| Selectable water levels  | 3                    | 3                              |
| Wash action  | Surgilator® agitator | Two-piece Surgilator® agitator |
| Total number of temperatures                                     | 4                    | 4                              |
| <b>WASH CYCLES</b>   |                      |                                |
| Total number of cycles   | 5                    | 8                              |
| Delicate cycle   | -                    | -                              |
| Prewash cycle  | -                    | -                              |
| Super Wash cycle   | -                    | -                              |
| <b>DRYER FEATURES</b>  |                      |                                |
| Dryer capacity (cu. ft.)   | 3.4                  | 5.9                            |
| Total number of cycles   | 18                   | 6                              |
| Total number of temperatures                                     | 4                    | 3                              |
| Timed drying   | -                    | -                              |
| Automatic Dry  | -                    | -                              |
| Tumble Press® cycle  | -                    | -                              |
| 2-way venting  | -                    | -                              |
| End-of cycle signal  | -                    | -                              |
| <b>ACCESSORIES</b>   |                      |                                |
| Dryer rack   | N/A                  | N/A                            |
| LP Gas Conversion kit  | 49573                | 3392235                        |
| 24"/27" Thin Twin® (stacked LDY) side exhaust vent extension kit | 279823               | 279823                         |
| 4" Gas Dryer Hook-Up kit   | 20-48KITRC           | 20-48KITRC                     |
| 4', 3-wire, 30 amp dryer cord                                    | PT220L               | PT220L                         |
| 4', 4-wire, 30 amp dryer cord                                    | PT400L               | PT400L                         |
| 6', 3-wire, 30 amp dryer cord                                    | PT500L               | PT500L                         |
| 6', 4-wire, 30 amp dryer cord                                    | PT600L               | PT600L                         |
| <b>DIMENSIONS AND COLORS</b>                                     |                      |                                |
| Max height (A)   | 71½"                 | 71½"                           |
| Width (B)  | 24"                  | 27"                            |
| Depth (C)  | 27½"                 | 32"                            |
| Available colors   | Q                    | Q                              |

Bold type indicates a step-up feature

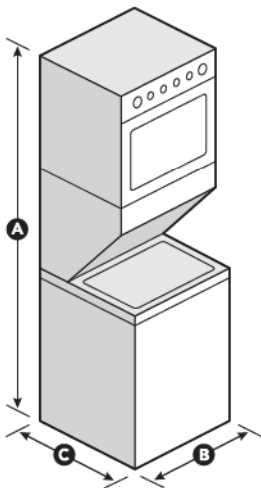

DIMENSIONS ARE SHOWN FOR PLANNING PURPOSES ONLY.  
For complete information, see Installation Instructions packed with product.

# Compact Laundry Pairs

## SPECIFICATIONS AND DIMENSIONS

| WHIRLPOOL®                       |                                    |
|----------------------------------|------------------------------------|
| <b>WASHER MODEL</b>              | <b>WFC7500V</b>                    |
| Washer capacity (cu. ft.)        | 2.0                                |
| Washer configuration             | Front load                         |
| ENERGY STAR® qualified           | -                                  |
| Meets CEE Tier standards*        | Tier 1                             |
| Estimated time remaining display | -                                  |
| Cycle status bar                 | -                                  |
| Lighted cycle indicators         | -                                  |
| Wash basket                      | Stainless steel                    |
| <b>WASH SYSTEM</b>               |                                    |
| Gentle wash system               | -                                  |
| Additive dispensers              | Detergent, bleach, fabric softener |
| Noise reduction system           | Quiet Wash                         |
| Max spin speed (RPM)             | up to 1,200                        |
| Automatic water level control    | -                                  |
| Total number of temperatures     | 3                                  |
| <b>CYCLES AND OPTIONS</b>        |                                    |
| Total number of cycles           | 8                                  |
| Heavy Duty cycle                 | -                                  |
| Quick Wash cycle                 | -                                  |
| Clean Washer cycle               | -                                  |
| Delicate cycle                   | -                                  |
| Prewash option                   | -                                  |
| Delay Wash option                | up to 12 hours                     |
| Extra Rinse option               | -                                  |
| <b>DIMENSIONS AND COLORS</b>     |                                    |
| Max height (A)                   | 32 <sup>3</sup> / <sub>8</sub> "   |
| Width (B)                        | 23 <sup>3</sup> / <sub>8</sub> "   |
| Depth (C)                        | 23 <sup>3</sup> / <sub>8</sub> "   |
| Depth with door open (D)         | 36 <sup>1</sup> / <sub>4</sub> "   |
| Available colors                 | W                                  |
| <b>DRYER MODEL</b>               | <b>WED7500V</b>                    |
| Capacity (cu. ft.)               | 3.8                                |
| Drum material                    | Stainless steel                    |
| End-of-cycle signal              | -                                  |
| Door window                      | -                                  |
| Side-swing door                  | -                                  |
| <b>DRYING SYSTEM</b>             |                                    |
| AutoDry™ drying system           | -                                  |
| Moisture sensor control          | -                                  |
| Long vent exhaust                | -                                  |
| Total number of temperatures     | 2                                  |
| Power source                     | 240 Volt                           |
| <b>CYCLES AND OPTIONS</b>        |                                    |
| Total number of cycles           | 11                                 |
| Damp Dry cycle                   | -                                  |
| Normal cycle                     | -                                  |
| <b>ACCESSORIES</b>               |                                    |
| Dryer stack kit                  | Included                           |
| Compact Dryer Stand kit          | N/A                                |
| 4', 3-wire, 30 amp dryer cord    | PT220L                             |
| 4', 4-wire, 30 amp dryer cord    | PT400L                             |
| 6', 3-wire, 30 amp dryer cord    | PT500L                             |
| 6', 4-wire, 30 amp dryer cord    | PT600L                             |
| <b>DIMENSIONS AND COLORS</b>     |                                    |
| Max height (A)                   | 33 <sup>1</sup> / <sub>4</sub> "   |
| Width (B)                        | 23 <sup>3</sup> / <sub>8</sub> "   |
| Depth (C)                        | 23 <sup>3</sup> / <sub>8</sub> "   |
| Depth with door open (D)         | 39"                                |
| Available colors                 | W                                  |

Bold type indicates a step-up feature

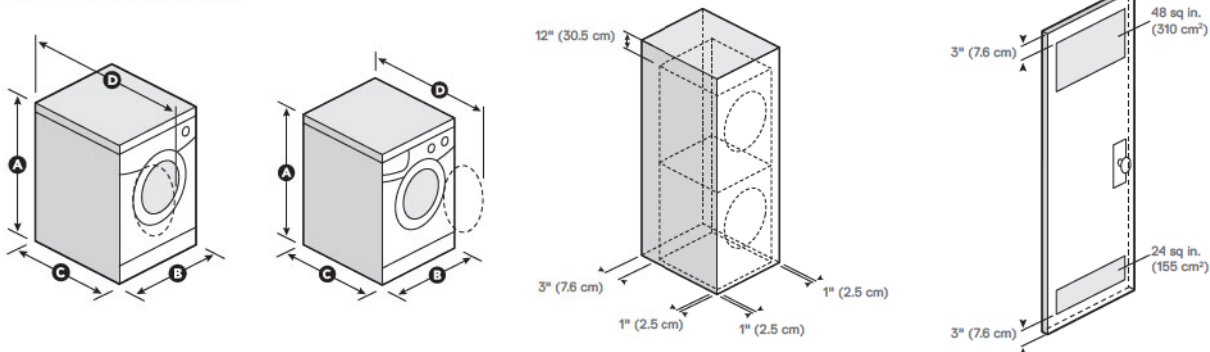

\*Based on the Consortium for Energy Efficiency qualifying product lists. Visit [cee1.org](http://cee1.org) for more information.

DIMENSIONS ARE SHOWN FOR PLANNING PURPOSES ONLY.  
For complete information, see Installation Instructions packed with product.

# Compact Laundry Pairs

## SPECIFICATIONS AND DIMENSIONS

| WASHER MODEL                 |  | WHIRLPOOL®                         |
|------------------------------|--|------------------------------------|
|                              |  | LCE4332P                           |
| Washer capacity (cu. ft.)    |  | 2.1                                |
| Washer configuration         |  | Top load                           |
| Lighted cycle indicators     |  | -                                  |
| Wash basket                  |  | Stainless steel                    |
| WASH SYSTEM                  |  |                                    |
| Gentle wash system           |  | -                                  |
| Additive dispensers          |  | Detergent, bleach, fabric softener |
| Wash speeds                  |  | 3                                  |
| Selectable water levels      |  | 2                                  |
| Straight vane agitator       |  | -                                  |
| Total number of temperatures |  | 3                                  |
| CYCLES AND OPTIONS           |  |                                    |
| Total number of cycles       |  | 4                                  |
| Heavy Duty cycle             |  | -                                  |
| Quick Wash cycle             |  | -                                  |
| Delicate cycle               |  | -                                  |
| DIMENSIONS AND COLORS        |  |                                    |
| Max height (A)               |  | 35"                                |
| Width (B)                    |  | 22½"                               |
| Depth (C)                    |  | 24"                                |
| Height with door open (D)    |  | 49¼"                               |
| Available colors             |  | Q                                  |

| DRYER MODEL                                      | LER3622P   | LDR3822P   |
|--|------------|------------|
| Capacity (cu. ft.)                               | 3.4        | 3.4        |
| Drum material                                    | DuraWhite™ | DuraWhite™ |
| End-of-cycle signal                              | -          | -          |
| Side-swing door                                  | -          | -          |
| Designed, engineered and assembled in the U.S.A. | -          | -          |
| DRYING SYSTEM                                    |            |            |
| AccuDry™ sensor drying system                    |            | ♦          |
| Gentle heat system                               | -          | -          |
| Total number of temperatures                     | 2          | 2          |
| Power source                                     | 240 Volt   | 120 Volt   |
| CYCLES AND OPTIONS                               |            |            |
| Total number of cycles                           | 3          | 3          |
| ACCESSORIES                                      |            |            |
| Dryer rack                                       | N/A        | N/A        |
| Compact Dryer Stand kit                          | 49971      | 49971      |
| 4', 3-wire, 30 amp dryer cord                    | PT220L     | PT220L     |
| 4', 4-wire, 30 amp dryer cord                    | PT400L     | PT400L     |
| 6', 3-wire, 30 amp dryer cord                    | PT500L     | PT500L     |
| 6', 4-wire, 30 amp dryer cord                    | PT600L     | PT600L     |
| DIMENSIONS AND COLORS                            |            |            |
| Max height (A)                                   | 31"        | 31"        |
| Width (B)  | 23⅞"       | 24"        |
| Depth (C)  | 21⅞"       | 21⅞"       |
| Depth with door open (D)                         | 37⅞"       | 37⅞"       |
| Available colors                                 | Q          | Q          |

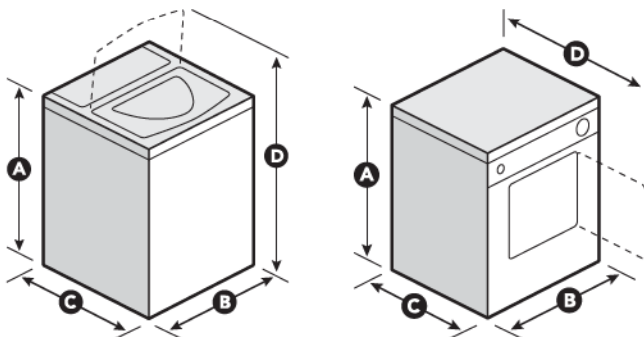

DIMENSIONS ARE SHOWN FOR PLANNING PURPOSES ONLY.  
For complete information, see Installation Instructions packed with product.



# Laundry 1-2-3™ Pedestals

## SPECIFICATIONS AND DIMENSIONS

| MODEL  | LAB0050P | XHP1000X | XHPC155X | XHPC155Y |
|--|----------|----------|----------|----------|
| Storage drawer                                   |          |          | ♦        | -        |
| Duet® pair compatible                            |          | ♦        | -        | -        |
| Chrome handle                                    |          |          | ♦        | -        |
| Designed, engineered and assembled in the U.S.A. | -        | -        | -        | -        |
| DIMENSIONS AND COLORS                            |          |          |          |          |
| Height   | 11.8"    | 10"      | 15.5"    | 15.5"    |
| Width  | 23.4"    | 27"      | 27"      | 27"      |
| Depth  | 20.1"    | 26.8"    | 27.3"    | 27.3"    |
| Available colors                                 | Q        | W        | W        | C   U    |

Bold type indicates a step-up feature

Whirlpool brand is constantly improving and innovating our products, so the specifications and dimensions in this catalog are subject to change without notice.

DIMENSIONS ARE SHOWN FOR PLANNING PURPOSES ONLY.  
For complete information, see Installation Instructions packed with product.



Whirlpool Corporation donates a range and an ENERGY STAR® qualified refrigerator to every new Habitat for Humanity home built in North America.



With 20,000 workers throughout the country, America is home to Whirlpool Corporation as it delivers world-class appliances and exceptional service.



  
**American  
Pride**

Designed, engineered and  
assembled in the U.S.A.

Designed to Simplify™  Whirlpool®